

Montana Stream Permitting

A Guide for Conservation District Supervisors and Others



Conservation Districts Bureau
Montana Department of
Natural Resources and Conservation
January 2020



CONTRIBUTORS

Montana Stream Permitting: A Guide for Conservation District Supervisors was first published in 2001 by 310 committee members interested in providing guidance to Montana Conservation District Supervisors for making decisions on 310 Permits.

- Mike Cobb, Lewis and Clark Conservation District
- Tara Comfort, Missoula County Conservation District
- Jim Elliott, Lewis and Clark Conservation District
- Chris Evans, Lewis and Clark Conservation District
- Roy Gabel, Yellowstone Conservation District
- Liz Galle-Noble, Upper Yellowstone Task Force
- Cary Hegreberg, Montana Wood Products Association
- LaVerne Ivie, Yellowstone Conservation District
- Cathy Jones, Flathead Conservation District
- Glenn Phillips, Montana Department of Fish, Wildlife and Parks
- Jeff Ryan, Montana Department of Environmental Quality
- Rose Shea, Montana Power Company
- Allan Steinle, U.S. Army Corps of Engineers
- Kit Sutherland, Bitterroot Resource Conservation and Development (facilitator)
- Todd Tillinger, U.S. Army Corps of Engineers
- Steve Vogt, Bitterroot Conservation District
- Gayla Wortman, Cascade County Conservation District

This current update maintains much of that information while highlighting new tools and information that support natural stream processes to meet the needs of all Montanans. Updating this Guide was done through a collaborative process involving input from several individuals, organizations, and agencies. The following represent the core working group for completing this update.

- Shawn Bryant, Montana Department of Transportation
- Jim Darling, Montana Department of Fish, Wildlife and Parks
- Beau Downing, Montana Natural Resource Damages Program
- Jonathan Ferree, Montana Department of Fish Wildlife and Parks
- Bob Flesher, Montana Department of Natural Resources and Conservation
- Jason Garber, Montana Department of Natural Resources and Conservation
- Michelle McGree, Montana Department of Fish Wildlife and Parks
- Robert Ray, Montana Department of Environmental Quality
- Jeff Ryan, Lewis and Clark Conservation District
- Lynda Saul, Montana Department of Environmental Quality
- Steve Story, Montana Department of Natural Resources and Conservation
- Todd Tillinger, US Army Corps of Engineers
- Eric Trum, Montana Department of Environmental Quality
- Larry Urban, Montana Department of Transportation
- Laurie Zeller, Montana Department of Natural Resources and Conservation

And numerous others who provided input and comments...

Bruce Anderson with WGM Group (Missoula, MT) provided the majority of research, writing, and photographs.

Additional photos, design drawings, and technical support were provided by Trout Unlimited, US Forest Service, Montana Department of Transportation, Bitterroot Water Forum, Big Hole Watershed Committee, River Design Group, Montana Department of Environmental Quality, Montana Department of Fish Wildlife and Parks, Applied Geomorphology, Gillilan Associates, Anabran Solutions, Sierra Wildlife Coalition.

Ross Campbell, Montana Department of Natural Resources and Conservation, completed the layout and design.

TABLE OF CONTENTS

Chapter 1

A GUIDE TO STREAM PERMITTING IN MONTANA	1.2
PERMITTING	1.3
310 PERMIT	1.7
FLOODPLAIN DEVELOPMENT PERMITS	1.11
404 PERMIT	1.20
401 WATER QUALITY CERTIFICATION	1.28
SECTION 10 PERMIT - FEDERAL RIVERS AND HARBORS ACT	1.29
318 PERMIT - SHORT TERM TURBIDITY	1.30
MONTANA LAND-USE LICENSE OR EASEMENT ON NAVIGABLE WATERS	1.31
WATER RIGHTS	1.33
FISH STOCKING PERMIT	1.35
SUMMARY OF PERMITTING EXPECTATIONS AND PROCESS	1.37
STORMWATER AND EROSION CONTROL BMPs FOR CONSTRUCTION	1.39
WORKING WITH A LANDOWNER’S REPRESENTATIVE(S)	1.40

Chapter 2

STREAM FORM AND FUNCTION	2.1
WATERSHEDS	2.2
GEOLOGY AND CLIMATE	2.3
STREAM CHANNEL FORM	2.4
THE LANE DIAGRAM	2.6
BANK AND CHANNEL STABILITY	2.8
BANK AND RIPARIAN VEGETATION	2.9
FLOW CHARACTERISTICS	2.10
FIELD INDICATORS OF BANKFULL FLOW	2.11
CHANNEL DOWNCUTTING & RE-ESTABLISHMENT OF EQUILIBRIUM	2.12
CHANNEL MIGRATION ZONES	2.13
MEANDER MOVEMENT AND BANK EROSION	2.14
CHANNEL CUTOFF (AVULSION)	2.15
ROLE OF LARGE WOODY DEBRIS	2.16
ROLE OF BEAVER DAMS	2.17
CASE STUDY - BIG SPRING CREEK	2.18

Chapter 3

ADDRESSING STREAMBANK EROSION	3.1
PROJECT PLANNING & DESIGN	3.2
STREAM CHANNEL PROCESSES - SUMMARY	3.3
PASSIVE RESTORATION - THE NO ACTION ALTERNATIVE	3.4
RIPARIAN MANAGEMENT	3.5
GRAZING MANAGEMENT - WATER GAPS and HARDENED CROSSINGS	3.6
LIVE CUTTINGS	3.8
DORMANT POLE PLANTINGS	3.9
REVEGETATION CONSIDERATIONS	3.10

MANAGING BEAVERS. 3.12

BEAVER MIMICRY 3.13

SOFT BIOENGINEERING. 3.14

FABRIC-WRAPPED BANKS 3.15

GEOTEXTILE EROSION CONTROL FABRICS 3.16

VEGETATED SOIL LIFTS. 3.17

BANKFULL BENCH/TERRACE 3.18

TOE PROTECTION 3.19

BRUSH FASCINES 3.20

BRUSH AND WOOD MATRIX 3.21

VEGETATED SOIL LIFT (Type 1) 3.22

VEGETATED SOIL LIFT (Type 2) 3.23

SOD AND BRUSH MATRIX (Types 1 and 2) 3.24

LARGE WOOD STRUCTURE 3.25

ROOT WADS / WOODY DEBRIS 3.26

ENGINEERED LOG JAM. 3.27

BARBS / VANES. 3.28

BENDWAY WEIRS. 3.29

ROCK V AND W WEIRS / CROSS VANES 3.30

RIP-RAP 3.32

CHANNEL RESTORATION APPROACHES 3.34

GEOMORPHIC DESIGN PRINCIPLES 3.35

RESTORING CHANNEL GEOMETRY. 3.36

AVULSIONS. 3.37

AGGRADATION 3.38

FLANKING 3.39

STREAMBANK CONSTRUCTION SEQUENCE. 3.40

Chapter 4

ROAD CROSSINGS AND CHANNEL GEOMETRY 4.2

ROAD APPROACHES 4.3

ROAD CROSSINGS AND SEDIMENTATION 4.5

FLOW CAPACITY 4.6

PLANNING FOR BEDLOAD / WOODY DEBRIS / ICE 4.7

CULVERTS. 4.8

BRIDGES 4.16

FORDS 4.20

Chapter 5

IRRIGATION DIVERSION STRUCTURES	5.1
DESIGN CONSIDERATIONS FOR IRRIGATION STRUCTURES	5.2
CONCRETE / WOODEN PIN & PLANK DIVERSIONS	5.3
ENGINEERED RIFFLE DIVERSION	5.4
ROCK WEIRS & VANES.....	5.5
GRAVEL BERM DIVERSIONS.....	5.6
DIVERSION BLOCKS.....	5.7
INFLATABLE GATE DIVERSIONS	5.8
INFILTRATION GALLERIES	5.9
FISH PASSAGE AT DIVERSIONS	5.10
GUIDELINES FOR SMALL DIVERSION DESIGN	5.12
HEADGATES.....	5.15
FISH SCREENS	5.16
FLOW MEASUREMENT DEVICES.....	5.20
DAMS AND SPILLWAYS.....	5.22

Appendix 1

ROSGEN STREAM CLASSIFICATION.....	Appendix 1.1
GEOMORPHIC CHARACTERISTICS AND RELATIVE STABILITY	
ROSGEN TYPE A.....	Appendix 1.2
ROSGEN TYPE B.....	Appendix 1.3
ROSGEN TYPE C	Appendix 1.4
ROSGEN TYPE E.....	Appendix 1.5
ROSGEN TYPES D, F, & G.....	Appendix 1.6
CHANNEL EVOLUTION OF ROSGEN STREAM TYPES	Appendix 1.7

Appendix 2

RIVER RESTORATION ANALYSIS TOOL (RiverRAT).....	Appendix 2.1
PROJECT DESIGN	Appendix 2.2
RIVERRAT SCHEMATIC	Appendix 2.3
RIVERRAT DESIGN CRITERIA.....	Appendix 2.4
DESIGN CRITERIA: CHANNEL FORM AND GEOMETRY.....	Appendix 2.5
DESIGN CRITERIA: VERTICAL STABILITY-INCISION	Appendix 2.6
VERTICAL STABILITY: AGGRADATION.....	Appendix 2.7
DESIGN CRITERIA: LATERAL CHANNEL AND BANK STABILITY.....	Appendix 2.8
DESIGN CRITERIA: FLOODPLAIN CONNECTIVITY	Appendix 2.10
DESIGN CRITERIA: REVEGETATION	Appendix 2.12
DESIGN CRITERIA: CHANNEL FUNCTION AND INSTREAM HABITAT ..	Appendix 2.13
DESIGN CRITERIA: INFRASTRUCTURE PROTECTION.....	Appendix 2.15
DESIGN CRITERIA: CONSTRUCTION COSTS AND IMPACTS	Appendix 2.16
DESIGN CRITERIA: SUSTAINABILITY CRITERIA	Appendix 2.17

Glossary

TERMS.....	G.1
------------	-----

ACKNOWLEDGMENTS

- Lane Diagram—Rosgen (1966); Lane (1955).
Classification of Alluvial Channels—Schumm (1977).
Channel Evolution Model—Simon (1989).
Stream Corridor Restoration: Principles, Processes, and Practices, USDA (1998).
Lane, E. W. 1955. The importance of fluvial geomorphology in hydraulic engineering. Proceedings of the American Society of Civil Engineers. 81 (745) :1-17.
Schumm, S. A. 1977. The Fluvial System. John Wiley and Sons, NY.
Seehorn, 1985. Drawing of Check Dam.
Simon, A. 1989. A model of channel response in distributed alluvial channels.
Lane, S.N., 2018. Earth Processes and Landforms. John Wiley and Sons.
Wheaton, J.M., et al. 2019. Low-Tech Process-Based Restoration of Riverscapes: Design Manual.

INTRODUCTION

This manual is designed to provide guidance to Montana Conservation District Supervisors in making decisions for 310 Permits and assisting landowners in considering the best options for working in and around streams, lakes, and rivers. The purpose of the Montana Natural Streambed and Preservation Act (310 Law) is to ensure that projects will be carried out in ways that minimize impacts to stream or river functions, or to adjoining landowners' property. While this guide can serve as an educational tool intended to be shared with landowners for more informed decision-making, we want to emphasize the importance of working with local and state resource and permitting specialists early on in the process to help identify the causes and most appropriate solutions for landowners and our shared water resources.

The guiding principle behind wise stream management is to select tools and methods that are compatible with a stream's natural tendencies, and to minimize undesirable side effects. Often, this means letting a stream set its own course, forming and re-forming natural meanders, or abiding by historical flood patterns. These are the lessons learned over fifty years ago when [concerned citizens and resource professionals](#) developed the Montana Stream Protection Act (124 Permit), the first state stream protection bill of its kind in the nation. The Natural Streambed and Land Preservation Act (310 Law) further expanded stream habitat protection in 1975.

When more hands-on management is necessary, the best tools and methods are those that support natural stream form and function. To that end, this manual includes chapters describing the permitting process, stream form and function, stream management methods to address streambank erosion, stream crossings, and irrigation structures.

Examples of stream projects are provided, along with design criteria for different types of projects. This document is a guide only and should not be construed as a rule for projects. The provided information is not a substitute for consulting professionals in the selection, design, permitting, and implementation of projects impacting Montana's rivers, lakes, and streams. Some conservation districts have adopted construction standards for certain projects and others may or may not allow all of the projects listed in this guide, depending on the local circumstances.

Finally, thank you for your work in protecting Montana's rivers, lakes and streams.

For more information, contact the Conservation Districts Bureau, Montana Department of Natural Resources and Conservation, 1539 Eleventh Avenue, Helena, MT 59620, (406) 444-6667.

INTRODUCTION TO STREAM PERMITTING

Permitting is a critical consideration when planning and designing a project. Permits help ensure that laws intended to protect stream, riparian, and floodplain resources are followed. Acquiring permits can be confusing, time consuming, and potentially costly. Depending on the location and size of project, both 404 permitting and floodplain permitting can be especially challenging. Planning for projects requiring these permits should be completed well in advance of project implementation.

It is important to involve all agencies with permitting authority early in the process to ensure that projects can be implemented as efficiently and effectively as possible. This section will address several key questions including:

- *Do I need a permit for my project?*
- *What permits will I need?*
- *How do I apply for those permits?*

Contents

A Guide to Stream Permitting in Montana.	1.2
Permitting	1.3
310 Permit	1.7
Floodplain Development Permits	1.11
404 Permit	1.20
401 Water Quality Certification	1.28
Section 10 Permit - Federal Rivers and Harbors Act	1.29
318 Permit - Short Term Turbidity	1.30
Montana Land-Use License or Easement on Navigable Waters	1.31
List of Navigable Rivers and Streams	1.32
Water Rights	1.33
Fish Stocking Permit	1.35
Summary of Permitting Expectations and Process	1.37
Stormwater and Erosion Control BMPS for Construction	1.39
Working with a Landowner’s Representative(s)	1.40

A GUIDE TO STREAM PERMITTING IN MONTANA

A Guide to Stream Permitting in Montana (flipbook) provides additional information on various permits required for working in and around Montana's streams and rivers. The brief descriptions of these permits (pages 1.2 - 1.5) follow the same order as that flip book and the joint application form. Remainder of this chapter provides more detailed information about these permits.

The diagram below outlines the area of jurisdiction for each of these laws and associated permits:

- A. Montana Natural Streambed and Land Preservation Act (310 Permit)
- B. Montana Stream Protection Act (SPA 124 Permit)
- C. Montana Floodplain and Floodway Management Act (Floodplain Development Permit)
- D. Federal Clean Water Act (404 Permit)
- E. Federal Rivers and Harbors Act (Section 10 Permit)
- F. Short Term Water Quality Standard for Turbidity (318 Authorization)
- G. Montana Land Use License or Easement on Navigable Waters
- H. Montana Water Use Act (Water Right Permit and Change Authorization)
- I. Montana Water Use Act (Water Reservations)
- J. Storm Water Discharge Permit Authorization
- K. Streamside Management Zone Law
- L. Other Laws That May Apply

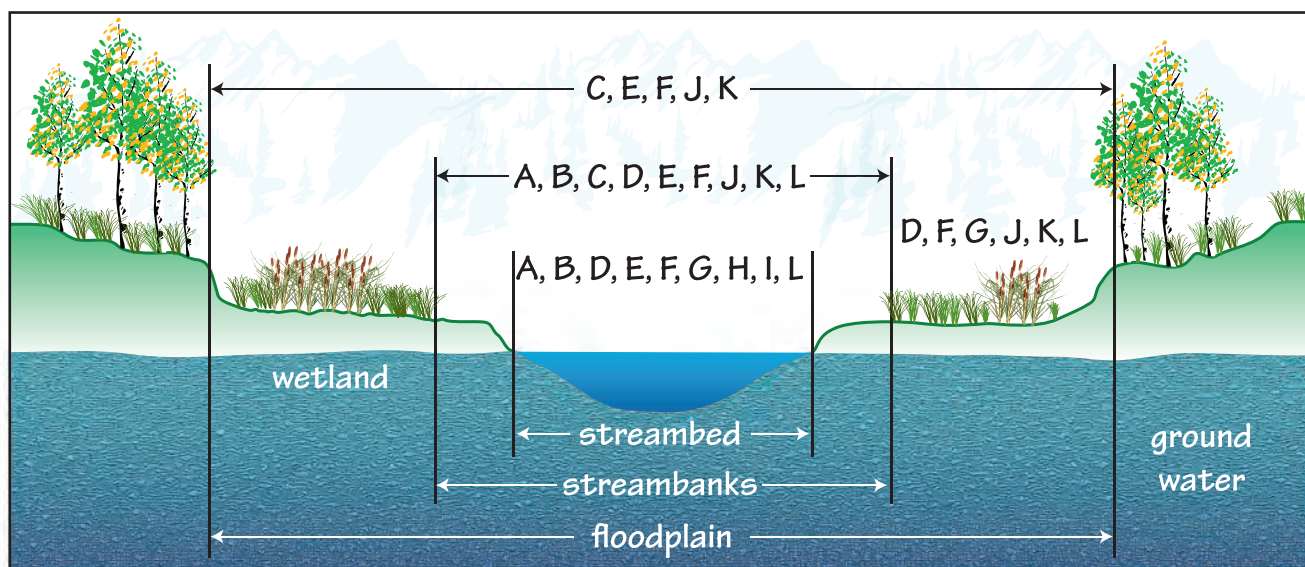

NOTE: The above graphic is only meant as a guide, please consult the permit descriptions to determine which permits are needed.

PERMITTING

Permits that may be applicable to projects affecting streambed, streambanks, or floodplain areas include:

- Montana Streambed and Land Preservation Act (310 Permit)
- Short-Term Turbidity (318 Permit)
- Federal Clean Water Act (404 Permit)
- Floodplain Development Permit
- Fish Stocking Permit
- Water Rights Permitting
- Montana Point Discharge Elimination System (MPDES) Stormwater Permit
- Montana Land-use License or Easement on Navigable Waters
- State Streamside Management Zone Law (SMZ)
- Montana Stream Protection Act (124 Permit)
- Section 10 Rivers and Harbors Act

These permits have similar information requirements. Fees vary depending on the permit and agency. An electronic version of the joint permit application is available online from most agencies.

Detailed information on individual permits is found in *A Guide to Stream Permitting in Montana* available from the **Montana Association of Conservation Districts, 1101 11th Avenue, Helena, Montana 59601**. This guide is also available online at www.dnrc.mt.gov.

If your project requires other permits besides a 310 Permit, it is your responsibility to contact the appropriate agency and submit the application to them.

Montana Streambed and Land Preservation Act (310 Permit)

This permit is required by any private, non-governmental person or entity that proposes to work in or near a stream on public or private land. The permit is necessary for any activity that physically alters or modifies the bed or banks of a perennially flowing stream.

**Contact: Local Conservation District
OR**

**Conservation Districts Bureau
Dept. of Natural Resources & Conservation
1539 11th Ave, P.O. Box 201601
Helena, Montana 59620-1601
Phone: (406) 444-6667**

Montana Stream Protection Act (124 Permit)

This permit is required by any state, county, or municipal agency, and the U.S. Bureau of Land Management and U.S. Forest Service, that proposes a project requiring alteration of the bed or banks of any stream, perennial or otherwise.

**Contact: Local Office of Montana Fish,
Wildlife & Parks
OR**

**Fish Management Bureau, Fisheries Division
Montana Fish, Wildlife and Parks
1420 E. 6th Ave, P.O. Box 200701
Helena, MT 59620-0701
(406) 444-2449**

PERMITTING (continued)

Montana Floodplain and Floodway Management Act (Floodplain Development Permit)

This permit is required for anyone planning new construction within a designated 100-year floodplain. Check with your local planning office to determine whether a 100-year floodplain has been designated for the stream of interest.

Projects that have the potential to alter the mapped 100-year flood elevation may require extensive hydraulic analysis and permit review. Details are found in the subsequent sections.

Montana Department of Natural Resources and Conservation
48 North Last Chance Gulch
P.O. Box 201601
Helena, Montana 59620-1601
Phone: (406) 444-6654, or (406) 444-6610

Federal Clean Water Act (404 Permit)

This permit is required by any person, agency, or entity, either public or private, proposing a project that will result in the discharge or placement of dredged or fill material into waters of the United States. *Waters of the United States* includes lakes, rivers, streams (including intermittent), wetlands, and other aquatic sites. Stream and wetland work may require mitigation of impacts, including the Montana Stream Mitigation Procedure (MSMP).

U.S. Army Corps of Engineers (USACE)
Montana Regulatory Office
10 West 15th Street, Suite 2200
Helena, Montana 59626
Phone: (406) 441-1375

Section 10 Rivers and Harbors Act

This permit is required for construction of any structure in, under, or over a federally listed navigable water of the United States, the excavation or deposition of material in such waters, or the accomplishment of any other work affecting the course, location, condition, or capacity of such waters. Navigable waters in Montana are the Missouri River downstream of Three Forks, the Yellowstone River downstream of Emigrant, and the Kootenai River from the Canadian border downstream to Jennings, Montana.

U.S. Army Corps of Engineers (USACE)
Montana Regulatory Office
10 West 15th Street, Suite 2200
Helena, Montana 59626
Phone: (406) 441-1375

Short-term Turbidity (318 Permit)

This permit is required for any person, agency, or entity, either public and private, initiating a short-term activity that may cause unavoidable short-term violations of state surface water quality standards. The major application of this law is related to sediments and turbidity caused by construction or other activities.

Water Protection Bureau
Water Quality Division
Department of Environmental Quality
1520 E. Sixth Avenue, P.O. Box 200901
Helena, Montana 59620-0901
Phone: (406) 444-3080

*PERMITTING (continued)***401 Water Quality Certification - Dredge & Fill**

States and Tribes make their decisions to deny, certify, or condition permits or licenses primarily by ensuring the activity will comply with state water quality standards. In addition, states and tribes look at whether the activity will violate effluent limitations, new source performance standards, toxic pollutants, and other water resource requirements of state/tribal law or regulation. The Section 401 review allows for better consideration of state-specific concerns.

**Department of Environmental Quality
Water Quality Division
Water Protection Bureau
1520 E. Sixth Avenue, P.O. Box 200901
Helena, Montana 59620-0901
Phone: (406) 444-3080**

Montana Land-use License or Easement on Navigable Waters

This permit is required for any entity proposing a project on lands below the low water mark of navigable waters.

**DNRC Land Office or
Special Use Management Bureau
Montana Department of Natural
Resources and Conservation
1539 11th Ave, P.O. Box 201601
Phone: (406) 444-7431**

Other permits may be required for stream projects but are not included in the Joint Application form. These include:

Montana Water Use Act (Water Right Permit and Change Authorization)

Diversion, appropriation, and beneficial use of surface and ground water in Montana requires a valid water right. New appropriations or changes in existing water rights require an application to be filed with the DNRC. Changes to existing rights may include alterations in place of use or point of diversion. Conversion of an existing water right from one use to another (e.g., irrigation to fish pond) require a change application. Certain uses are exempt from new appropriation, such as small, individual wells. Be sure to consult with DNRC before using new water or changing existing water rights/uses.

**Montana Department of Natural
Resources and Conservation
Water Rights Bureau
1424 9th Ave, P.O. Box 201601
Helena, Montana 59620-1601**

Civil Works (Section 408)

Section 408 provides that USACE may grant permission for another party to alter a Civil Works project upon a determination that the alteration proposed will not be injurious to the public interest and will not impair the usefulness of the Civil Works project. USACE has established the following policy and procedures for implementing Section 408.

**U.S. Army Corps of Engineers (USACE)
Montana Regulatory Office
10 West 15th Street, Suite 2200
Helena, Montana 59626
Phone: (406) 441-1375**

PERMITTING (continued)

Montana Pollution Discharge Elimination System (MPDES) Stormwater Permit

This permit is required for any person, agency, or entity proposing construction, industrial, or mining activity that will discharge stormwater to Montana waters and construction that will disturb more than one acre within 100 feet of streams, rivers, or lakes. Construction dewatering is also covered by MPDES permitting.

**Department of Environmental Quality
Water Quality Division
Water Protection Bureau
1520 E. Sixth Avenue, P.O. Box 200901
Helena, Montana 59620-0901
Phone: (406) 444-3080**

Streamside Management Zone Law (SMZ)

This permit is required for any landowner or operator conducting forest practices that will access, harvest, or regenerate trees on a defined land area for commercial purposes on private, state, or federal lands.

**Montana Department of Natural Resources and Conservation
Forestry Division
2705 Spurgin Road
Missoula, Montana 59801**

Fish Stocking Permit

Fish stocking of a private pond may legally be undertaken only after a Non-Commercial Private Fish Pond License has been issued by Montana Fish, Wildlife & Parks (MFWP).

If a pond meets certain requirements, the owner of the pond may qualify for a fish stocking license. This allows the pond owner to “stock the fish pond with” approved fish species “procured from any lawful source” and to “take fish from the lake or pond in any manner.” State fishing regulations and licenses are not required to take fish from a private pond.

**Montana Fish, Wildlife & Parks
P.O. Box 200701, 1420 East Sixth Avenue
Helena, Montana 59620-0701
Phone: (406) 444-2535**

Tribal Aquatic Permits

Conducting work in streams, rivers, lakes or wetlands within a Reservation generally requires a permit issued by the environmental office of the Tribe. Examples of these include the Shoreline Protection Act 64A application (Confederated Salish and Kootenai Tribes of the Flathead Nation), and the Aquatic Lands Protection Ordinance 90-A (Blackfeet Nation). Each Tribe has its own process and requirements, and should be consulted directly for specifics. In general, Tribal permitting requirements mirror state and federal permits.

310 PERMIT

Projects on Perennial Streams

The 310 permit applies to the bed and banks of perennial streams and is intended to protect the natural function of streams and rivers. Proposed projects are reviewed by Conservation District staff and Montana Fish, Wildlife & Parks (MFWP).

Application Process

A Joint Application along with a plan, details of the proposed project and a site map must be provided. The Joint Application is available online, or from the Conservation District office. Applications are reviewed and accepted at monthly Conservation District meetings, and must be submitted one week in advance of the meeting to be considered. After a project is accepted, MFWP is notified of the proposed project and may request an on-site inspection.

Site Inspection

A team consisting of a District representative, a MFWP representative and the landowner or landowner's representative will meet to discuss the project on site. This is an opportunity for the applicant to present the project, discuss options, and give and receive feedback from the District team members and MFWP staff. Following the inspection, team members make recommendations to the District at a regular meeting.

Decision Making

The District Board will decide whether to approve, modify, or deny the project within 60 days of acceptance of the application. However, this time period can be extended if the District determines it necessary to collect further information. After receiving the Conservation District Board's decision, the applicant has 15 days to return the permit, signed to indicate agreement with the District's decision. Unless otherwise stated on the supervisor's decision form, the applicant must wait 15 days before proceeding with the project unless the Board waves this waiting period.



Replacement or maintenance of irrigation structures are common 310 projects.



Any modification of the bed or banks of a perennial stream requires review under 310.



Projects to stabilize eroding streambanks require a 310 permit.

310 PERMITTING REVIEW CONSIDERATIONS

The Conservation District's Review

By Montana Statute, the Conservation District is required to consider the following factors in a 310 permit application:

Erosion and Sedimentation

Review of the potential effects of the project on erosion and sedimentation, considering the methods available to complete the project and nature and economics of various alternatives.

Stream Channel Alteration

Review of the effects of stream channel alterations to minimize adverse impacts and maintain the integrity and function of the natural channel.

Streamflow, Turbidity and Water Quality

Projects must keep impacts to water quality to a minimum, including potential effects of project materials used or removal of ground cover.

Effects on Fish and Aquatic Habitat

Projects must minimize adverse effects to fish and aquatic habitat. This includes criteria such as fish passage and bank/streambed alterations that impair resource values.

Avoid Harmful Flooding or Erosion

The project must avoid creating harmful flooding or erosion upstream or downstream.

Minimize Vegetation Disturbance, Protect Existing Vegetation, Control Weeds

Projects should seek to preserve, establish, or enhance native vegetation on the banks and floodplain.

The District will consider whether there are modifications or alternative solutions that are reasonably practical that would reduce disturbance to the stream and its environment and better accomplish the goals of the project.

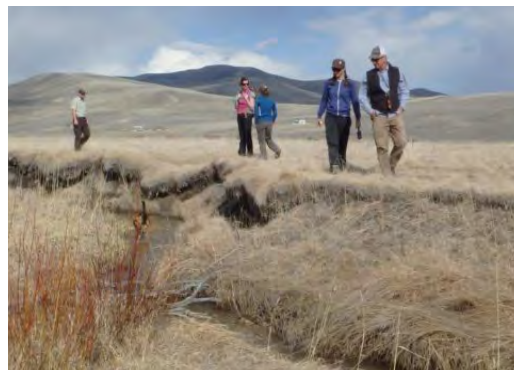

Conservation District staff perform field reviews of proposed projects, along with a representative from MFWP.

SPA 124 PERMIT

What is this?

The SPA 124 Permit is a result of the passing of the Stream Protection Act of 1963. Originally, it was primarily for road construction projects. The SPA 124 permit is very similar to the 310 Permit but is for Government agencies as opposed to private parties. It also applies to all streams, not just perennial streams. The purpose of this permit is to maintain streams and rivers in their natural existing state and to protect and preserve fish and wildlife resources.

Application Process

The Joint Application (same form as 310 permitting) is submitted to MTFWP in Helena. The application should be submitted no less than 60 days before the intended date of construction. MTFWP has up to 30 days to review the application, perform an on-site investigation, and approve, modify, or deny the application. There is no application fee.

310 TEAM MEMBER REPORT

Form 272 (Rev. 06/01/06) (filename 27206)

STATE OF MONTANA NATURAL STREAMBED AND LAND PRESERVATION ACT (310 LAW)	Application No. _____ Date Submitted to District _____
TEAM MEMBER REPORT	

1. Applicant _____
 Name of perennial stream _____ County _____
 Location of proposed activity ____ • ____ • ____, Section _____ Township _____ Range _____

2. Onsite inspection at _____ on _____ at _____.
 (location) (date) (time)

3. Review considerations:	Insignificant	Moderate	Significant	N/A
(a) effects of soil erosion and sedimentation:	<input type="checkbox"/>	<input type="checkbox"/>	<input type="checkbox"/>	<input type="checkbox"/>
(b) risk of flooding or erosion problems upstream or down:	<input type="checkbox"/>	<input type="checkbox"/>	<input type="checkbox"/>	<input type="checkbox"/>
(c) effects of stream channel alterations:	<input type="checkbox"/>	<input type="checkbox"/>	<input type="checkbox"/>	<input type="checkbox"/>
(d) effects on streamflow, turbidity, or water quality caused by materials used or by removal of ground cover:	<input type="checkbox"/>	<input type="checkbox"/>	<input type="checkbox"/>	<input type="checkbox"/>
(e) effects on fish and aquatic habitat:	<input type="checkbox"/>	<input type="checkbox"/>	<input type="checkbox"/>	<input type="checkbox"/>
(f) are there reasonable alternatives to reduce disturbance to stream or better accomplish the purpose of the project?	<input type="checkbox"/> • yes (see below)		<input type="checkbox"/> • no	

4. Recommendation:
 Approval as proposed
 Approval with modifications
 Denial
 Request for time extension

5. Modifications/Comments:
 • See attached (if more room is necessary)

6. Signature of Team Member(s)

 Name/Representing • Waive 15-day waiting period after board's decision Date _____

 Name/Representing • Waive 15-day waiting period after board's decision Date _____

 Name/Representing • Waive 15-day waiting period after board's decision Date _____

DENYING A 310 PERMIT APPLICATION

The 310 law requires a conservation district to determine 1) the purpose of the project – this is usually straight forward, but sometimes it isn't; and 2) whether the project is a reasonable means of accomplishing the purpose of the project. (75-7-112(9))

In order to determine if the project is reasonable, the applicant has to provide enough information for the board to make a determination. The factors that supervisors review are outlined in the law. They are: (75-7-112 (9)(i) through (vi)).

- i. The effects on soil erosion and sedimentation, considering the methods available to complete the project and the nature and economics of the various alternatives;
- ii. Whether there are modifications or alternative solutions that are reasonably practical that would reduce the disturbance to the stream and its environment and better accomplish the purpose of the proposed project;
- iii. Whether the proposed project will create harmful flooding or erosion problems upstream and downstream;
- iv. The effects on stream channel alteration;
- v. The effects on streamflow, turbidity, and water quality caused by materials used by or removal of ground cover; and
- vi. The effects on fish and aquatic habitat.

The supervisors may not approve or modify a proposed project unless the supervisors determine that the purpose of the proposed project will be accomplished by a reasonable means. (75-5-112 (11))

The applicant must provide supervisors with the above information and the team inspection report includes these factors on the form. There are other factors that are included the rules, which are included on an expanded team report that a few CDs use when needed.

The team report has check boxes to evaluate using a scale of no impact to significant impact (some are yes or no). If the board determines that a project is not reasonable, it should be based on these factors. Any project that falls in the significant impact range of any of these factors would probably be denied. It may also be denied if too many of the factors have moderate impacts that could be mitigated. The applicant then has the choice to reapply addressing the board's concerns, or to agree to modifications that will reduce the impacts.

FLOODPLAIN DEVELOPMENT PERMITS

Projects located in a Federal Emergency Management Agency (FEMA) regulatory floodplain must receive a floodplain permit before proceeding to construction. The floodplain development permit embodies regulations developed by FEMA and DNRC, which are administered by local governments. Local ordinances and requirements vary, so applicants will need to work with their local floodplain manager to determine individual requirements based on their proposed project.

Floodplain Mapping

Many rivers and streams have designated Flood Insurance Rate Maps (FIRMs) that define the regulatory floodplain. The digital form (DFIRM) is available online from the FEMA flood map service center and some county websites. Floodplain mapping defines the Regulatory Flood Hazard Areas associated with the 100 year flood. These areas are broadly grouped into floodway (typically deeper flow in or adjoining main channel) or flood fringe (shallower flow or inundated areas). In areas with detailed flood studies, the mapping defines Base Flood Elevations (BFEs) and delineates various regulatory zones (e.g., Zone A, AE, AO, X) within the floodplain. Some waterways have less detailed regulatory mapping, such as approximate Zone A designations.

Floodplain Zones

Zoning in the floodplain determines what uses are prohibited, permitted, or exempt from certain floodplain permitting requirements. The Floodway (e.g., Zones A or AE) is most restrictive, and the shallower flood fringe (e.g., Zone AO) allows for more potential uses. Permitted uses within designated flood zones vary by jurisdiction. In general, areas in the floodway do not generally allow for permanent residential or non-residential buildings, development, modification of the floodplain topography that would adversely impact floodplain function, sanitary disposal, storage of hazardous materials or objects that could float or move during a 100-year flood.



Detailed floodplain studies define 100-year flood elevations and extents of inundation.

LEGEND

	SPECIAL FLOOD HAZARD AREAS (SFHAs) SUBJECT TO INUNDATION BY THE 1% ANNUAL CHANCE FLOOD The 1% annual chance flood (100-year flood), also known as the base flood, is the flood that has a 1% chance of being equaled or exceeded in any given year. The Special Flood Hazard Area is the area subject to flooding by the 1% annual chance flood. Areas of Special Flood Hazard include Zones A, AE, AH, AO, AR, A99, V, and VE. The Base Flood Elevation is the water-surface elevation of the 1% annual chance flood.
ZONE A	No Base Flood Elevations determined.
ZONE AE	Base Flood Elevations determined.
ZONE AH	Flood depths of 1 to 3 feet (usually areas of ponding); Base Flood Elevations determined.
ZONE AO	Flood depths of 1 to 3 feet (usually sheet flow on sloping terrain); average depths determined. For areas of alluvial fan flooding, velocities also determined.
ZONE AR	Special Flood Hazard Areas formerly protected from the 1% annual chance flood by a flood control system that was subsequently decertified. Zone AR indicates that the former flood control system is being restored to provide protection from the 1% annual chance or greater flood.
ZONE A99	Area to be protected from 1% annual chance flood by a Federal flood protection system under construction; no Base Flood Elevations determined.
ZONE V	Coastal flood zone with velocity hazard (wave action); no Base Flood Elevations determined.
ZONE VE	Coastal flood zone with velocity hazard (wave action); Base Flood Elevations determined.
	FLOODWAY AREAS IN ZONE AE The floodway is the channel of a stream plus any adjacent floodplain areas that must be kept free of encroachment so that the 1% annual chance flood can be carried without substantial increases in flood heights.
	OTHER FLOOD AREAS
ZONE X	Areas of 0.2% annual chance flood; areas of 1% annual chance flood with average depths of less than 1 foot or with drainage areas less than 1 square mile; and areas protected by levees from 1% annual chance flood.
	OTHER AREAS
ZONE X	Areas determined to be outside the 0.2% annual chance floodplain.

Detailed studies define various zones within the floodway and the flood fringe.

FLOODPLAIN DEVELOPMENT PERMITS *(continued)*

Flood Fringe

Flood fringe areas allow for some development, improvement to existing structures, some types of new structures provided certain requirements are met. These involve specific requirements for flood-proofing, structure elevations, analysis of impacts to the bankfull elevation (BFE), and other analyses.

Local floodplain regulations must meet minimum standards to comply with FEMA requirements. Requirements vary by local, zoning designation, project specifics, and other site specific considerations. Vetting a project with your local floodplain administrator should be undertaken early in the process.

Hydraulic Analyses

Hydraulic analyses must demonstrate any expected change in base flood elevations, engineered stability criteria in a 100-yr flood, analysis of effects of erosion up or downstream, and various additional requirements involving flood safety.

This permit may require channel survey and hydraulic modeling for analysis of pre- and post-project base flood elevations, especially for larger projects. Changes in base flood elevations due to the project (even decreases in flood height) may need to be documented with FEMA through a Letter of Map Revision (LOMR).

No-Rise Analysis

A no-rise analysis is a hydraulic assessment of predicted effects of the proposed project on modeled 100-year flood elevations. This requires the development of the following models, in sequence:

Current Effective Model: This existing hydraulic model is obtained from FEMA or your local Floodplain Administrator.

Duplicate Effective Model: This original, current effective model is duplicated in contemporary hydraulics software, such as HEC-RAS.

Corrected Effective Model: This model corrects any errors in the Duplicate Effective model, adds any additional cross sections, or incorporates more detailed topographic information than that used in the current effective model. The Corrected Effective model must not reflect any man-made physical changes since the date the effective model was completed.

Existing or Pre-Project Conditions Model: Revises the Duplicate Effective or the Corrected Effective model to reflect any modifications that have occurred within the floodplain since the date of the Effective model but prior to the construction of the project.

Proposed or Post-Project Conditions Model: Modify the Existing Condition to reflect revised or post-project conditions. The results of this analysis will demonstrate the 100-year elevation (BFE) for proposed conditions at the project site. These results must indicate NO impact (i.e., 0.00 ft) on the BFE when compared to the Existing Conditions or Pre-Project Conditions model. Typically, a Conditional Letter of Map Revision (CLOMR) and LOMR is necessary for a rise, but only a LOMR is needed for decreases or structure changes in a detailed floodplain (pending the discretion of the floodplain administrator).

*FLOODPLAIN DEVELOPMENT PERMITS (continued)***Many Flavors of the FEMA Process**

FEMA regulations administered by the local floodplain staff can entail a variety of permitting requirements. These may include: LOMA, LOMR, CLOMR, LOMR-F and others.

LOMA

A Letter of Map Amendment (LOMA) is an official amendment, by letter, to an effective National Flood Insurance Program (NFIP) map. A LOMA establishes a property's location in relation to the regulatory floodplain. LOMAs are usually issued because a property has been inadvertently mapped as being in the floodplain, but is actually on natural high ground above the base flood elevation.

LOMR-F

A Letter of Map Revision Based on Fill (LOMR-F) is FEMA's modification of the regulatory floodplain shown on the Flood Insurance Rate Map (FIRM) based on the placement of fill inside the existing regulatory floodway.

CLOMR/LOMR

A Conditional Letter of Map Revision Based on Fill (CLOMR) is a proposed modification to the regulatory floodplain shown on the FIRM based modifications that alter the BFE or lateral extent of flooding. Examples would be projects that cause a predicted change in the BFE by more than 0.00 ft. Bridges, floodplain fill/excavation, irrigation diversions within the channel, and dikes/levees may require CLOMR/LOMR because they may affect the NFIP map. Decreases in the BFE may not require a CLOMR, but only a LOMR. Official floodplain extents and base flood elevations are public records the county/city must maintain for the community.



Regulatory floodplains have been defined for many locations in Montana. New construction within the floodway or flood fringe is regulated.

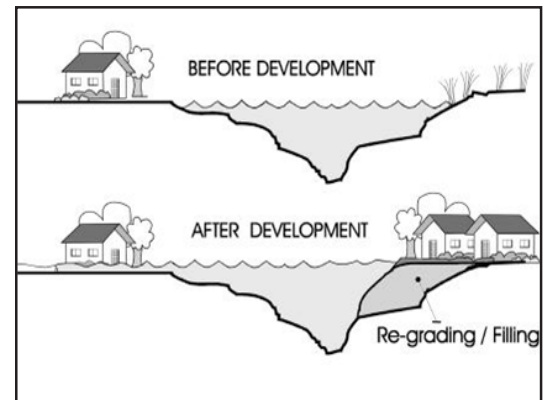

Fill within the regulatory floodplain requires analysis to quantify potential impacts to flood elevations.

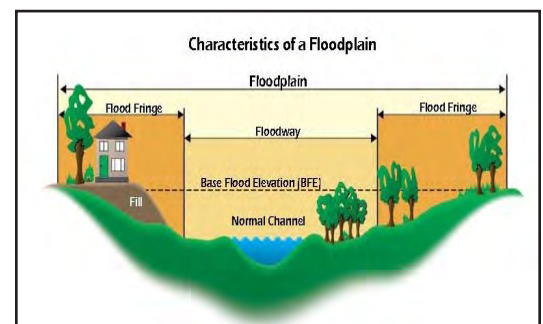

Some types of development may be allowable in the flood fringe with appropriate permitting.

FLOODPLAIN DEVELOPMENT PERMITS *(continued)***MT-2 Application Forms**

Conditional Letters of Map Revisions (CLOMR), Letter of Map Revision (LOMRs) and Physical Map Requests are submitted using a MT-2 application.

The application forms and instructions included in the MT-2 forms package were designed to assist requesters (community officials or individuals via community officials) in gathering the data that FEMA needs to determine whether the effective National Flood Insurance Program (NFIP) map (i.e., Flood Hazard Boundary Map, Flood Insurance Rate Map, Flood Boundary and Floodway Map or Digital Flood Insurance Rate Map) and Flood Insurance Study report for a community should be revised.

These forms also should be used by community officials or individuals via community officials for requesting FEMA comments on a proposed project issued in the form of a CLOMR. These forms assure FEMA that all pertinent data relating to the request is included in the submittal. They also ensure that:

- the data and methodology are based on current conditions
- qualified professionals have assembled the data and performed necessary computations
- the individuals and organizations affected by proposed changes are aware of the changes and have an opportunity to comment



The FEMA permitting process is intended to provide protection to existing and future development. Potential changes to regulatory BFE must be carefully evaluated.



Evaluating complex channels in floodplains can be difficult even for professionals, and costly for the client.

CLOMR AND PERMITTING PROCESS FLOWCHART

Coupling CLOMR and Encroachment Analysis Requirements with the Floodplain Permitting Process

Conditional Letter of Map Revision (CLOMR)

- Must be received prior to permit issuance
- Based on proposed design

Letter of Map Revision (LOMR)

- Must be completed after construction to update maps
- Based on as-built conditions

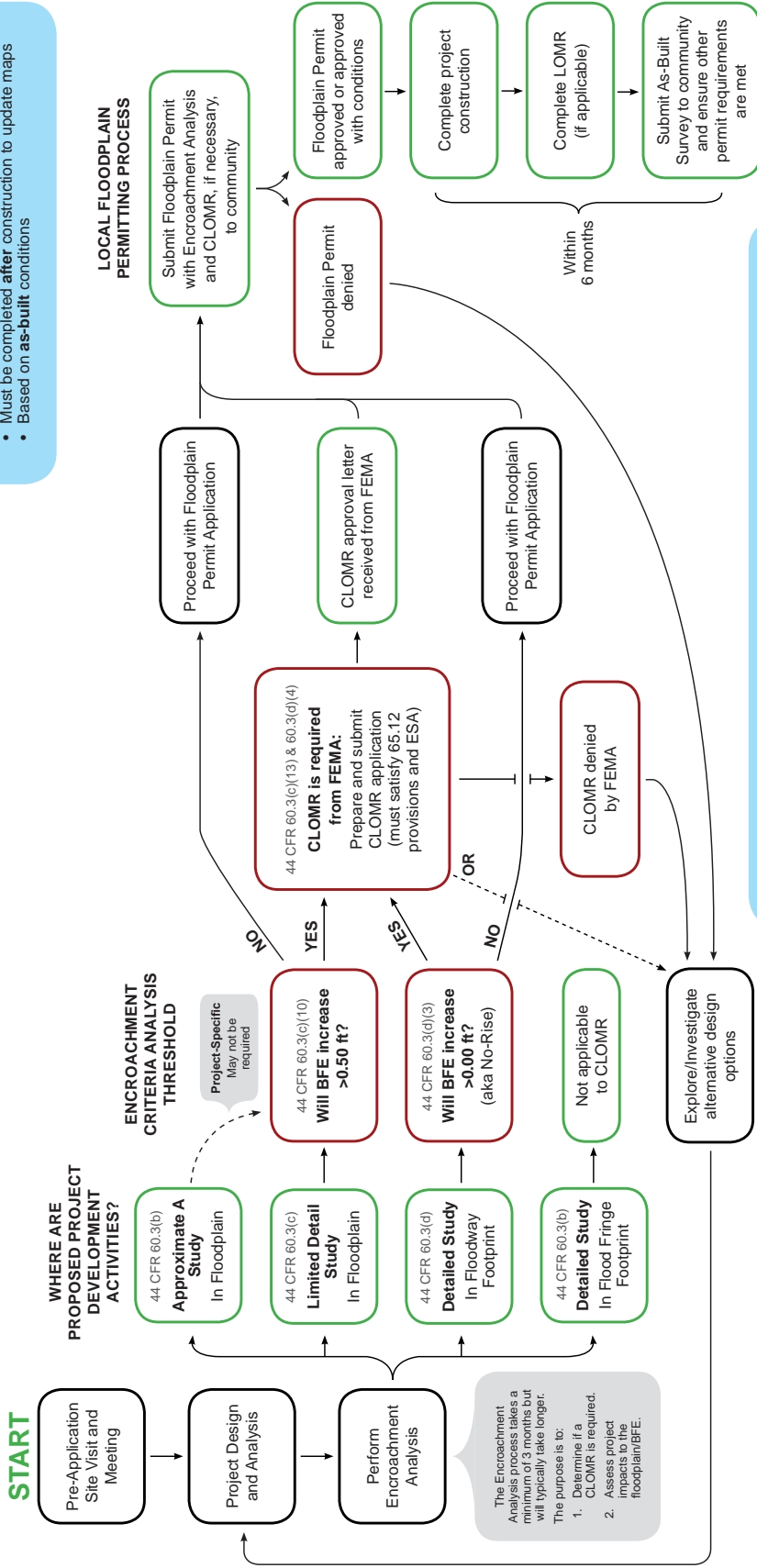

44 CFR 65.12 Requirements: Criteria for CLOMR application and approval

- Alternatives analysis
- No structures impacted
- Legal Notice to impacted property owners
- Signature of community
- Adopt in local ordinance upon approval
- Complete LOMR based on As-Built Survey



ENCROACHMENT THRESHOLD CRITERIA
When No-Rise Analyses & CLOMRs are Required

These criteria are based on development impacts to the BFE, not the type of project, and are to be applied uniformly to all projects.

44 CFR	<p>DETAILED LEVEL FLOOD STUDY (Zones AE, A1-A30, AO, AH, & A)</p> <ul style="list-style-type: none"> Includes Floodway Developed using H&H, field survey, high-resolution topography 	<p>0.00ft ≥ BFE increase > 0.00ft</p> <p>Okay. Proceed with floodplain permitting process.</p> <p>CLOMR is required and satisfy 65.12 provisions.</p>	
60.3(d)	<p>Encroachment threshold:</p> <ul style="list-style-type: none"> For development activities within Floodway footprint } Doesn't apply in Flood Fringe area BFE increase ≤ 0.00ft 	<p>No-Rise/Encroachment Analysis</p> <ul style="list-style-type: none"> Determines whether or not CLOMR is required. Must be included with floodplain permit application. 	
60.3(d)(3)	<p>Prohibit encroachments, including fill, in Floodway unless demonstrated no increase in BFEs (demonstrated by H&H analysis, standard engineering practice).</p>	<p>or</p> <p>Must apply for CLOMR approval from FEMA and satisfy 65.12 provisions and ESA prior to permit issuance.</p>	
60.3(d)(4)	<p>Must apply for CLOMR approval from FEMA and satisfy 65.12 provisions and ESA prior to permit issuance.</p>		
44 CFR	<p>LIMITED DETAIL LEVEL FLOOD STUDY (Zones AE, A1-A30, AO, AH, & A)</p> <ul style="list-style-type: none"> Includes BFEs but NO Floodway Developed using H&H, field survey, medium-resolution topography 	<p>0.50ft ≥ BFE increase > 0.50ft</p> <p>Okay. Proceed with floodplain permitting process.</p> <p>CLOMR is required and satisfy 65.12 provisions.</p>	
60.3(c)	<p>Encroachment threshold:</p> <ul style="list-style-type: none"> For development activities within Floodplain footprint BFE increase ≤ 0.50ft 		
60.3(c)(10)	<p>Demonstrate cumulative effect of development on BFE < 0.50ft → 0.50ft-Rise/Encroachment Analysis</p>		
60.3(c)(13)	<p>or</p> <p>Must apply for CLOMR approval from FEMA and satisfy 65.12 provisions and ESA prior to permit issuance.</p>		
44 CFR	<p>APPROXIMATE A LEVEL FLOOD STUDY (Zone A)</p> <ul style="list-style-type: none"> No BFE/WSEL data and NO Floodway No H&H, low-resolution topography model (typically) } Multiple vintages, now/legacy 		
60.3(b)	<p>Encroachment threshold:</p> <ul style="list-style-type: none"> For development activities within Floodplain footprint Community has the option to require 0.50ft-Rise/Encroachment Analysis (done on a case-by-case basis) 		
ARM 36.15.801(3)	<p>May request additional H&H information, including a study, etc.</p>		
60.3(b)(4)	<p>Review and utilize any BFE and Floodway data available.</p>		
60.3(b)(7)	<p>Assure the flood-carrying capacity of watercourse is maintained.</p>	<p>CLOMR threshold not specifically established by FEMA. } A community has the option to require it from the applicant (case-specific).</p>	



- 44 CFR 65.12 Requirements: Criteria for CLOMR application and approval**
- Alternatives analysis
 - Legal Notice to impacted property owners
 - Signature of community
 - No structures impacted
 - Adopt in local ordinance upon approval
 - Complete LOMR based on As-Built Survey

*FLOODPLAIN DEVELOPMENT PERMITS (continued)***Commonly Required Information**

The following overview provides an introduction to information commonly required for all floodplain permits. These requirements also apply more generally to state and federal permits conducted on streams and rivers in Montana.

To initiate the floodplain permit process, you will need to submit a copy of the following information, according to your type of project. Many of these items are also a requirement of the Joint Application. These instructions apply to **all construction projects** within any designated 100-year floodplain as delineated on agency floodplain maps.

1. A list of adjacent property owners and their mailing addresses (You can get this information from the county or through a title company.)
2. A letter from each property owner where the project will be completed authorizing the proposed work
3. A detailed site plan, drawn to scale, showing the following:
 - Property boundary lines of the subject property and those in the immediate vicinity of the project
 - Approximate location of all floodplain boundaries in the vicinity of the project as depicted on the floodplain maps
 - Location of existing improvements in the vicinity of the project, including driveways, roads, culverts, bridges, buildings, wells, septic systems, and other improvements
 - Location of all existing physical features in the vicinity of the project, including ponds, swales, streams, and irrigation ditches
 - Location and dimensions of all proposed improvements, including driveways, roads, culverts, bridges, ponds, buildings, wells, and other structures
 - Location for all fill that will be brought into the floodplain
4. A statement specifying the amount of fill that will be placed within the floodplain and supporting calculations
5. For bank stabilization, submit:
 - Description of existing conditions
 - Historical overview of trends in the river movement, if any
 - Description of the problem
 - Description of the objectives of the project
 - Short description of design alternatives that were considered but rejected (if any), and an explanation of why each was rejected
 - Typical cross-section of the river from bank to bank (based on survey data), which shows the existing condition and proposed treatment and the height of the 100-year flood event (BFE), the base flow elevation, and the bank full elevation
 - Longitudinal profile of the river surface and bed in the project area
 - Plan view of the project (using an aerial photograph as a base), which shows the beginning and ending points of the various types of treatment
 - Specifications for the treatment material (type, size, quantities, etc.)

FLOODPLAIN DEVELOPMENT PERMITS *(continued)*

- Calculations to show the proposed project in an Approximate A Zone or AE Zone without a floodway will not raise the elevation of the 100-year flood (BFE) more than 0.5 feet above the published 100-year floodplain elevation as documented on the floodplain maps. In cases where the threshold is exceeded, the applicant may be required to apply for a Conditional Letter of Map Revision (CLOMR) from FEMA and should coordinate with the local Floodplain Administrator. (Please contact DNRC Helena to develop appropriate language for this statement.)
 - Description of the project implementation (project phases, sediment control, staging area, cleanup, etc.)
6. For a bridge, submit:
 - Drawings and specifications for the bridge as certified by a professional engineer
 - Calculations for the amount of fill to be placed in the floodplain
 - A cross-section at the location of the bridge which shows the existing condition and the elevation of the 100-year flood event
 7. For a pond, submit:
 - Description of existing conditions
 - Description of the objectives of the project
 - Calculations for the amount of material to be removed from the pond
 - Description of where the material will be placed outside the floodplain
 8. For a road, submit:
 - Description of existing conditions
 - Description of the objectives of the project
 - Calculations to show the culverts will be large enough to handle the expected flows



Bridge crossings and channel modifications require extensive hydraulic analysis for floodplain permitting.

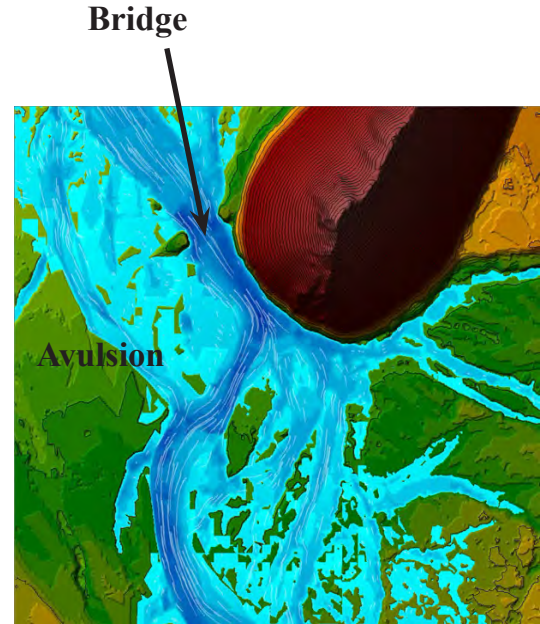

A HEC-RAS 2D model was used to simulate pre- and post-project flood conditions and demonstrate that 100 year flood elevation was unaffected by the project.

FLOODPLAIN DEVELOPMENT PERMITS *(continued)***Review Process**

All floodplain applications shall also include a definitive signed statement from a qualified engineer demonstrating:

- The project can withstand a 100-year flood
- The project will not adversely affect land owners upstream, downstream, across stream or adjacent to the proposed project area
- Analysis of what effect this proposed project will have on the 100-year BFE

Stream and bank restoration projects are frequently designed to be “deformable,” or having softer treatments, and may be specifically designed to enable dynamic, long-term channel adjustment. In other words, these projects may not meet traditional engineering stability criteria for a 100-year flood. These projects must be evaluated on a case-by-case basis by the local floodplain manager.

Once submitted, the application will be reviewed to make sure the information is sufficient. If it is not sufficient, the applicant will receive a letter that explains the deficiencies. As part of the review process, the adjoining property owners will be notified about the proposed work, and a legal notice placed in the paper containing a brief description of the application, with a 30 day public comment period. Additional requirements/processes are involved for fill activities or construction of roads or buildings within the floodplain.

Detailed information is published on the DNRC website. However, local floodplain managers will need to be consulted on requirements specific to your project. Application fees vary depending on county/city, as do time frames for approval. Plan for 90 days in most cases.



Although floodplain permitting can be time consuming and costly, the process helps ensure that existing and future development minimizes risk of flooding problems. Note the high water mark/debris at the base of the sign.

404 PERMIT

The 404 Permit is administered by US Army Corps of Engineers (USACE) and regulates fill in jurisdictional streams and wetlands under the Clean Water Act. The Federal permitting process requires compliance with other Federal statutes including the Endangered Species Act (ESA).

Jurisdictional Waters

Rivers streams and wetlands subject to 404 permitting generally include navigable waters, interstate waters, perennial and intermittent streams, or wetlands connected to navigable waters. Isolated wetlands (e.g., upland potholes), disconnected ephemeral stream segments, and some “artificial” human-caused wetlands may not be subject to 404 permitting requirements. The determination of whether a stream or wetland is jurisdictional is made on a case-by-case basis by USACE staff.



Many wetlands are obvious to a lay person, but wetlands don't require open water to be jurisdictional. Fill within wetlands, floodplains, and stream channels generally requires a 404 permit.

Application Process

The Joint Application (same form as 310 permitting) is submitted to USACE in Helena. The application is reviewed for completeness, with particular attention to the quantity and placement of any proposed fill materials. USACE staff can provide guidance on application requirements based on the proposed project. In many cases, a formal wetland delineation and professional assistance may be needed to determine the extent of jurisdictional wetlands and impacts of any fill activities. USACE also reviews proposed project for compliance with other federal regulations, such as the Endangered Species Act (ESA), Cultural Resources (SHPO).

Obtaining a 404 permit may require a qualified professional to assist with technical requirements, especially for larger projects. However, even smaller projects under “Nationwide” permits are required to comply with Federal statute. Technical issues that are generally beyond a lay-person’s knowledge include:

- Biological Assessment for Endangered Species
- Wetland Delineation
- Streambank and Wetland Mitigation

Plan Ahead

Depending on the complexity of the project, permitting may require 3 months to a year or more to obtain the permit. Small projects that fit into the “Nationwide” permit categories typically require 3-6 months, “Individual” permits require more extensive supporting documentation and review. Consultation with USACE staff in advance of submitting an application can help clarify requirements and expedite the process. Fees are not charged for general permits, transferring a permit from one property owner to another, for Letters of Permission, or for permits to governmental agencies or non-profit groups. Fees are required for most individual permits. The current fee is \$10.00 for a permit for a non-commercial activity and \$100.00 for a permit for a commercial or industrial activity.

404 PERMIT TYPES

Permits for new projects will generally fall under either the “Nationwide” or “Individual” permit types. The following discussion provides a brief overview. Federal 404 regulations are complex, subject to revision, and applicants are encouraged to consult with USACE staff to determine which requirements apply to their project.

Nationwide Permits

These fall under 52 categories, and are often appropriate for projects such as culvert and bridge replacements, bank stabilization under 500 feet in length, and stream restoration activities. The Nationwide permits (NWP) come with certain “standard” conditions and Best Management Practices which must be followed. Several common Nationwide Permits are: Maintenance of Existing Structures (NWP3), Utility Lines (NWP12), Bank Stabilization (NWP13), Aquatic Restoration (NWP27), agricultural activities (NWP40), and reshaping existing drainage ditches (NWP41).

Individual Permits

These apply to larger projects that exceed limits or conditions of the NWP criteria. These permits are reviewed under the lengthier Individual Permit process, and may require analyses such as a Biological Assessment (BA), detailed wetland delineation, stream and wetland mitigation, and other requirements. The Individual Permit process often requires a year or more for final approval.



River banks and floodplains are commonly jurisdictional waters of the U.S. The immediate river bank on all navigable waters below the ordinary high water mark (OHWM) will be jurisdictional. However, not all floodplains will be jurisdictional for 404 depending on the presence of wetlands.

**Non-Jurisdictional
Dryland**

**Jurisdiction
Wetland**



The differences between jurisdictional and non-jurisdictional areas may be subtle. Wetland delineations generally require a trained professional.

401 Certification

The State of Montana (MDEQ) participates in the Federal 404 permitting process through the 401 certification <http://deq.mt.gov/Water/Permits/401and318>. MDEQ reviews USACE 404 applications to ensure the activity will comply with state water quality standards, and MDEQ may deny, certify, or condition permits. Section 401 certification review fee is a minimum of \$400.00, or 1 percent of the gross value of the proposed project, not to exceed \$20,000.00. Appropriate review fees along with documentation of the gross value of any proposed project needs to be submitted with any 401 application. These fees may be waived for smaller projects on a case-by-case basis. Counties, incorporated cities or towns, and conservation districts are not subject to fees related to 401 Certification.

AGRICULTURAL EXEMPTIONS FROM 404 PERMITTING

Certain agricultural practices may be exempt from 404 permitting. These include:

- Established (ongoing) farming, ranching, and silviculture activities such as plowing, seeding, cultivating, minor drainage, harvesting for the production of food, fiber, and forest products, or upland soil and water conservation practices
- Maintenance (but not construction) of drainage ditches
- Construction and maintenance of irrigation ditches, and farm or stock ponds
- Construction and maintenance of farm and forest roads, complying with best management practices
- Maintenance of structures such as dams, dikes, and levees

Agricultural Activities Not Exempt

If an activity listed above as exempt represents a new use of the water, and the activity would result in a reduction in reach or impairment of flow or circulation of regulated waters, including wetlands, the activity is not exempt. Both conditions must be met in order for the activity to be considered non-exempt. In general, any discharge of dredged or fill material associated with an activity that converts a wetland to upland is not exempt and requires a 404 permit.

New drainage ditch



Maintenance of existing drainage ditches is exempt from 404 permitting. Construction of new drainage ditches is not exempt.



Isolated wetlands, which are not connected to stream and river systems, may be exempt from 404 regulation.

CAUTION

Plan Ahead All applicants are advised to consult with USACE staff well in advanced to determine which permitting criteria potentially apply to their project.

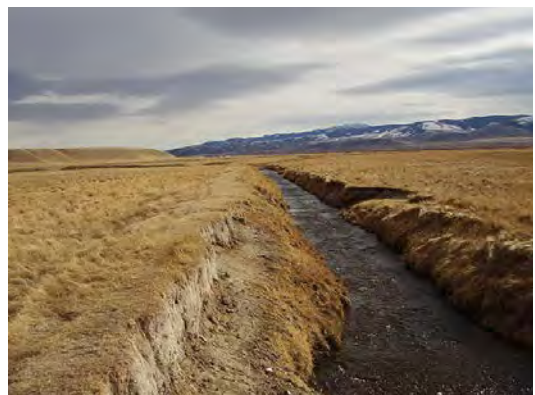

Construction and maintenance of irrigation ditches is normally exempt from 404.

404 ENDANGERED SPECIES COMPLIANCE

Endangered Species

In western Montana, many stream projects are located in waters that support Bull Trout, a threatened species under the Endangered Species Act (ESA). If your project is located on a stream listed by the U.S. Department of Fish and Wildlife (USFWS) as critical habitat for Bull Trout, USACE is required to consult with the USFWS to determine the project's impacts on endangered species habitat under Section 7 and Section 10 provisions of the ESA.

Additional species that may require special consideration include Pallid and Kootenai River White Sturgeon, Sage Grouse, Bald and Golden Eagles, certain plant species (e.g., *Howelia*), etc.

Biological Assessment

USACE must provide a biological assessment (BA) to the USFWS to help determine possible effects on Bull Trout (or other species). USACE will develop a BA if none is supplied by the applicant. However, review periods can be substantially shortened if the applicant chooses to submit one written by a qualified consultant. If USACE must write the BA, a review period of a year or more is common. If a BA is provided by the applicant, the review period is usually on the order of 6 to 12 months.

SLOPES Procedure

SLOPES (Standard Local Operating Procedures for Endangered Species) helps streamline the permitting of projects in listed species streams. The project must meet certain conditions to minimize the potential to impact endangered species. Among numerous criteria are bank stabilization not exceeding 300 feet in length, preference for bioengineering techniques, construction "in the dry" and only during certain times of the year, and a host of other considerations. If a project meets SLOPES criteria, the need for a BA can be reduced or eliminated, and the permitting time is shortened.

Additional information on SLOPES is found in the appendix.



This river bank is jurisdictional under 404 and a project would require review under ESA provisions because of Bull Trout.



Impacts to Bull Trout (threatened under the ESA) must be minimized during construction and following completion of the project.

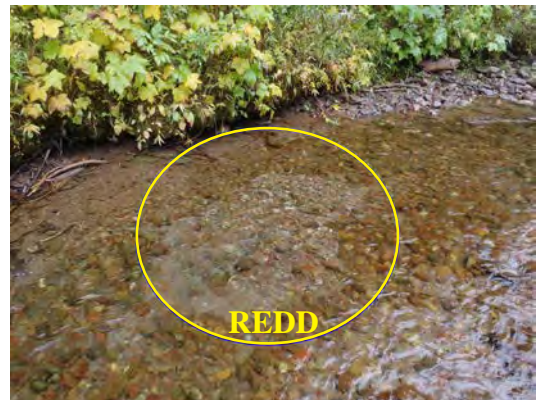

Tributaries are particularly important to Bull Trout spawning. Redds are clean patches of gravel created by fish to place eggs during spawning. Areas where redds are found are particularly high value.

404 WETLAND ISSUES

Stream projects generally affect wetland areas to some extent, even if only along the edge of the stream channel. Impacts may be minimal, such as temporary access across soft ground during construction, or may include permanent changes, such as dikes, fill, or excavation. Although stream permitting may not address all aspects of specific wetland impacts, projects that directly or inadvertently affect wetlands may be regulated by the 404 permitting process.

Identifying wetland areas that are “jurisdictional” under Clean Water Act Section 404 is not always obvious. Wetlands are defined by a certain combination of soils, vegetation, and hydrology. Wetland does not simply mean areas with standing, shallow water and cattails. Pasture, floodplain, swampy areas flooded from ditch leakage, etc. may all be subject to wetland law. In more difficult situations, a trained specialist is required to make a “wetland delineation.” National Resources Conservation Service staff, USACE, and other trained professionals can make these determinations.

Because specific exemptions exist and federal wetland law changes over time, it is difficult to generalize which stream projects or related activities may be regulated. The safe approach is to submit a 404 application to USACE, and let the agency make the determination about the project.

404 permit reviewers want to know where excavated fill materials will be placed (even if off-site) and the quantities and types of imported materials (such as rock) used on the project. Temporary or permanent access roads for the project should be accurately described.

Permitting through the Clean Water Act Section 404 may also require an evaluation of cultural resources, endangered species, historic structures, and other considerations related to federal law.



Wetlands frequently include areas adjacent to the stream channel that may not be wet during most of the year.



Wetland regulations may apply to activities in residential, agricultural, and industrial sites. Excavation and fill, cleaning, grubbing, or other alterations may fall under 404 permitting.



Jurisdictional wetlands include much of the area in this photo, not just the wet area.

404 WETLAND DELINEATIONS

A formal wetland delineation is required for most projects. This requires a trained professional to evaluate the soils, hydrology, and vegetation at the project site, and to determine what impacts the project will have to jurisdictional wetlands. Jurisdictional wetlands are often not apparent to a lay-person, and a trained specialist is typically needed to interpret these areas according to technical guidance established by USACE. Seasonally wet soils are a common indicator. Pooled or standing water is not necessary to define jurisdictional wetlands.

Wetland delineations are conducted using a technical guidance manual developed by USACE in 1987, and also a 2010 regional supplemental manual for the great plains, arid west and western mountains.

- The distribution and abundance of individual plant species are evaluated to determine the prevalence of wetland-specific species.
- Soil types are reviewed using NRCS mapping, and soil pits are employed to review hydric (saturated) conditions.
- Site hydrology including frequency and duration of seasonally saturated soil conditions is evaluated.
- The delineation requires mapping the boundary of the wetland using GPS or survey.

The wetland delineation report helps determine the amount (if any) of mitigation required based on impacts of the proposed project.



Soil pits are used to evaluate hydrology and hydric soil conditions.

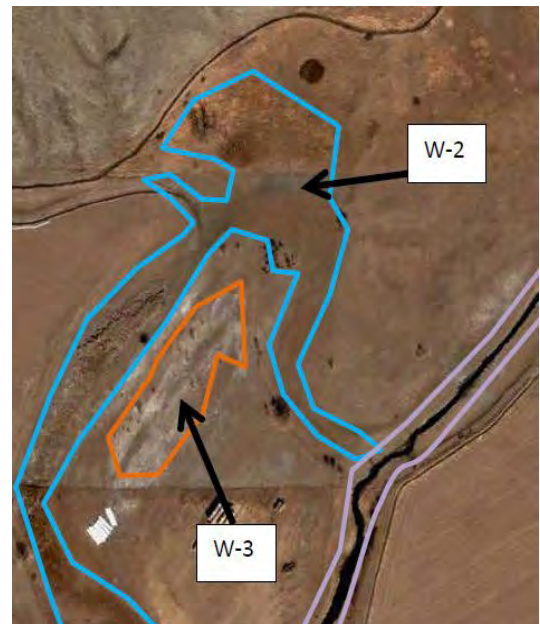

Wetland delineations require surveyed and mapped boundaries. This map shows two distinct wetlands in the project area.

Plan Ahead

By statute, 404 permits require wetland delineations to characterize “special waters of the U.S.” which may be impacted. At their discretion, USACE may accept and approve smaller projects without a formal wetland delineation. Project planning should take into account that wetland delineations are normally done during the growing season, and are difficult or impossible to conduct in the winter. Applicants should consult with USACE staff in Helena to determine what technical information will be required for their project. The Corps receives thousands of requests each year to perform wetland delineations for potential applicants for permits under Section 404 of the Clean Water Act. Due to limited staff and resources, response time can be several months or longer depending upon workload and the time of year. To expedite this process, the Corps encourages applicants to use consultants to conduct wetland delineations, especially for large and/or complex areas.

404 STREAM AND WETLAND MITIGATION

Avoid, Minimize, Mitigate.

Permitting for 404 generally follows the sequence: avoid impacts, minimize impacts, and mitigate impacts to wetlands and streambanks. Those impacts that have been minimized and cannot be avoided will often require mitigation if they exceed certain thresholds. Both wetland and streambank mitigation have specific procedures and worksheets which must be followed to determine debits and credits for a proposed project.

Wetland Impacts

The formal wetland delineation will assist in establishing the extent of wetland impacts. Depending on the type of project, as little as 0.1 acre of wetland impact may trigger the need for wetland mitigation. A qualified professional can help guide your project and review with USACE staff.

Stream Impacts

Mitigation may also be required for certain stream channel modifications including bank stabilization projects. Projects between 150 and 300 linear feet in length can require streambank mitigation on a case-by-case basis. Projects over 300 feet in length usually require mitigation under the Montana Stream Mitigation Procedures (MSMP). MSMP requires calculation of debits and credits to offset impacts of streambank stabilization projects. The USACE has a specific procedure and spreadsheet for calculating mitigation requirements. The softer and more environmentally-friendly the bank stabilization design, the less mitigation is required. Fully soft bank restoration may require no mitigation because they may be viewed as improvements to the physical, chemical, and biological characteristics of a stream. Purchase of mitigation credits can add substantial cost to a stream project. Information on stream mitigation can be obtained from USACE.



Jurisdictional wetlands are common in agricultural wet meadows and subirrigated areas. Baltic Rush and Nebraska Sedge are two common indicator plant species.



Bank stabilization projects longer than 300 feet will require stream mitigation under the Montana Stream Mitigation Procedures. Hard stabilization using riprap typically requires much more mitigation than bioengineering techniques.

On-site wetland mitigation may be possible if sufficient wetland values can be created.

404 MITIGATION TAKES MANY FORMS

Compensatory mitigation is the restoration, establishment, enhancement, or preservation of aquatic resources for the purpose of offsetting losses of aquatic resources resulting from activities authorized by Corps of Engineers' permits. In general, mitigation available to an applicant to compensate for project impacts falls under four major categories.

- Obtain credits from an established mitigation bank
- Obtain credits from an approved In-Lieu-Fee (ILF) sponsor
- Permittee-responsible mitigation (i.e., do-it-yourself)
- A combination of some or all of the above options

Permit applicants are encouraged to consult with the Corps early in the permit application process to discuss potential compensatory mitigation alternatives

Mitigation Bank Credits

The applicant may elect to purchase credits from an established stream or wetland mitigation bank as long as impacts are within the bank's service area and the bank has appropriate credits available. This approach offers convenience, as credits are "pre-approved" and effective immediately, requiring no additional effort by the project permittee.

In-Lieu Fee (ILF) Credits

The applicant may procure credits from an ILF sponsor who will commit to providing the compensatory mitigation. Information can be found on the [Montana Aquatic Resources Services \(MARS\)](#) website.

Permittee-Responsible Mitigation

The applicant may elect to prepare their own mitigation proposal or hire a consultant to prepare a mitigation plan which must be approved by USACE. In this case, the Permittee retains all the responsibilities for the mitigation obligations. Mitigation may be achieved through on-site and in-kind mitigation, including such strategies as conservation easements, stream setbacks, fencing, and aquatic restoration activities. Though more challenging to organize and administer, off-site mitigation is also a possibility.



The Nevada Spring Creek mitigation bank restored a creek in the Blackfoot Valley (photo immediately after construction).



The restored reach of Nevada Spring Creek post construction. Post construction provided both wetland and stream credits.



Nevada Spring Creek before and after restoration.

401 WATER QUALITY CERTIFICATION

FOR 404 PERMITS & OTHER FEDERAL PERMITS AND APPLICATIONS

401 Water Quality Certification - Dredge & Fill

Under Section 401 of the federal Clean Water Act, states and tribes can review and approve, condition, or deny all Federal permits or licenses that might result in a discharge to State or Tribal waters, including wetlands. The major Federal licenses and permits subject to Section 401 are Section 402 and 404 permits (in non-delegated states), Federal Energy Regulatory Commission hydropower licenses, and Rivers and Harbors Act Section 9 and 10 permits. States and tribes may choose to waive their Section 401 certification authority.

States and Tribes make their decisions to deny, certify, or condition permits or licenses primarily by ensuring the activity will comply with state water quality standards. In addition, states and tribes look at whether the activity will violate effluent limitations, new source performance standards, toxic pollutants, and other water resource requirements of state/tribal law or regulation. The Section 401 review allows for better consideration of state-specific concerns.

Current fee rules became effective February 15, 2002, and require that fees be submitted with completed applications for certification. As noted in the fee rules (17.30.201(6)(o)), the Section 401 certification review fee is a minimum of \$400.00, or 1 percent of the gross value of the proposed project, not to exceed \$20,000.00. Appropriate review fees along with documentation of the gross value of any proposed project needs to be submitted with any 401 application. The check should be made payable to the Water Protection Bureau, DEQ and on the memo section of the check, a notation indicating the name of the proposed project and that it is for a Section 401 Water Quality Certification review.

Counties, incorporated cities or towns, and conservation districts are not subject to fees related to 401 Certification.

SECTION 10 PERMIT - FEDERAL RIVERS AND HARBORS ACT

Section 10 of the Rivers and Harbors Act of 1899 requires that regulated activities conducted in, over, or under navigable waters of the United States, or any work that would affect the course, location, condition or capacity of those waters, be approved/permittted by the U.S. Army Corps of Engineers. Regulated activities include the placement/removal of structures, work involving dredging, disposal of dredged material, filling, excavation, or any other disturbance of soils/sediments or modification of a navigable waterway.

Navigable waters of the United States are those waters of the U.S. that are subject to the ebb and flow of the tide shoreward to the mean high-water mark and/or are presently used, or have been used in the past or may be susceptible to use to transport interstate or foreign commerce. **Navigable waters of the U.S. are not necessarily the same as state navigable waterways** (list on page 1.32). Tributaries and backwater areas associated with navigable waters of the U.S., and located below the OHW elevation of the adjacent navigable waterway, are also regulated under Section 10. When adjacent wetlands are present, the jurisdiction extends beyond the ordinary high water mark to the delineated limit of the adjacent wetlands.

Corps of Engineers Regulatory Jurisdiction

Fresh Waters

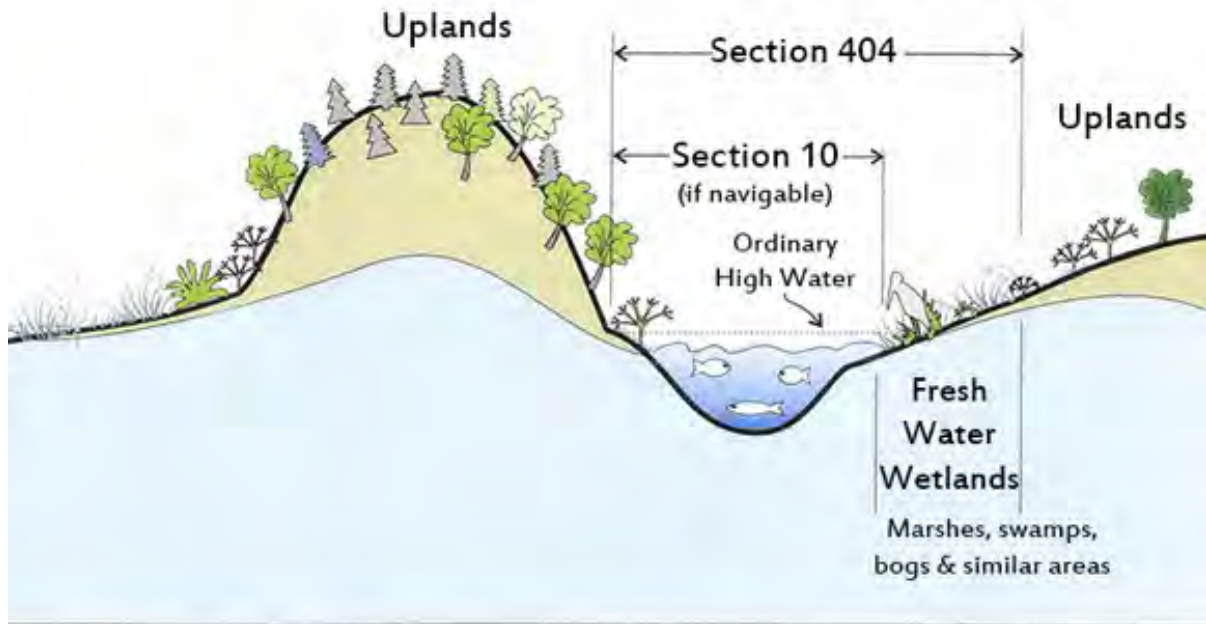

Section 404

Disposal of Dredged or Fill Material
All filling activities, utility lines, outfall structures, beach nourishment, riprap, jetties, some excavation activities, etc.

Section 10

All Structures and Work (navigable waters)
Dredging, marinas, piers, wharves, floats, intake/outtake pipes, pilings, bulkheads, ramps, fills, overhead transmission lines, etc.

318 PERMIT - SHORT TERM TURBIDITY

Who Must Apply?

Any person, agency, or entity, both public and private, initiating construction activity that will cause short term or temporary violations of state surface water quality standards for turbidity.

Activities Requiring a Permit

Any activity in any state water that will cause unavoidable short term violations of water quality standards. "State water" includes any body of water, irrigation system, or drainage system, either surface or underground, including wetlands, except for irrigation water where the water is used up within the irrigation system and the water is not returned to other state water.

Applications Procedure/Timeline

A 318 Authorization must be obtained prior to initiating a project. The authorization may be obtained from the Department of Environmental Quality, or may be waived by Montana Fish, Wildlife & Parks during its review process under the Natural Streambed and Land Preservation Act (310 Permit) or the Stream Protection Act (SPA 124 Permit).

Under certain circumstances, Montana Fish, Wildlife & Parks can issue 318 permits on behalf of the Montana Department of Environmental Quality.

Individual applications submitted to the Department of Environmental Quality are normally processed within 30 to 60 days. Authorizations waived under the 310 or SPA 124 permit processes correspond to the time frame under each permit system, usually 30 to 60 days. There is an application fee of \$250.00 (make check or money order payable to Water Protection Bureau, Department of Environmental Quality).



Projects that may result in temporary sediment introduction to a stream will require a 318 permit allowing work to be completed with an emphasis on a minimum of sediment introduction.

MONTANA LAND-USE LICENSE OR EASEMENT ON NAVIGABLE WATERS

Who Must Apply?

Any entity proposing a project on lands below the low water mark of navigable waters.

Activities Requiring a Permit

The construction, placement, maintenance, or modification of a structure or improvements in, over, below, or above a navigable river. If in doubt, contact the Department of Natural Resources and Conservation Land Office nearest to the project area for a determination of the navigability of the river.

This permit program does not apply to mining, mineral, or oil and gas activities in navigable rivers.

Applications Procedure/Timeline

A DNRC Land Use License or Easement Application, along with the nonrefundable application fee, must be submitted to the appropriate Land Office nearest to the project area. DNRC staff will review the application, conduct a field investigation if necessary, and file an environmental action checklist as appropriate. A written report and recommendation is then submitted to the Real Estate Management Bureau in Helena, which makes the final determination and recommends stipulations as necessary.

A Land Use License can normally be reviewed, approved, and issued within 60 days upon the payment of the \$50 application fee and a minimum annual rental fee. The license may be held for up to 10 years, with the ability to request renewal for an additional 10 years. An easement requires approval from the Board of Land Commissioners, which normally takes up to 90 days. The current easement application fee is \$50, with an additional fee for the easement itself.

The following Rivers and Streams and portions of Rivers and Streams are considered Navigable by the State of Montana

BIG HOLE RIVER - from Steel Creek to Divide, Montana.

BIG HORN RIVER - from the Wyoming state line to its confluence with the Yellowstone River.

BITTERROOT RIVER - from the confluence of its east and west forks to its confluence with the Clark Fork River.

BLACKFOOT RIVER - from Lincoln, Montana to its confluence with the Clark Fork River.

BOULDER RIVER (Tributary to the Yellowstone River) - from the northern township line of Township 6 South, Range 12 East, to its confluence with the Yellowstone River. The west Boulder River is commercially navigable from the southern line of Township 3 South, Range 11 East, to its confluence with the main stem of the Boulder River.

BULL RIVER - from a point south of Bull Lake to its confluence with the Clark Fork River.

CLARK FORK RIVER - from Deerlodge, Montana to the Idaho state line.

CLEARWATER RIVER - from, and including, Seeley Lake, to its confluence with the Blackfoot River.

DEARBORN RIVER - from Highway 434 to its confluence with the Missouri River.

DUPUYER CREEK - See 'South Fork Dupuyer Creek'.

FLATHEAD RIVER (MAIN STEM) - from the confluence of its north and middle forks to its confluence with the Clark Fork River.

However, given Neman court case, the state does not claim any river ownership within the boundaries of the Flathead Indian Reservation at this time.

FLATHEAD RIVER (MIDDLE FORK) - from Nyack, Montana to its confluence with the north fork of the Flathead River.

FLATHEAD RIVER (NORTH FORK) - from Logging Creek to its confluence with the main stem of the Flathead River.

FLATHEAD RIVER (SOUTH FORK) - from the face of Hungry Horse Dam to the main stem of the Flathead River.

FORTINE CREEK (Tributary to Tobacco River) - from Swamp Creek to its confluence with the Tobacco River.

GALLATIN RIVER - from Taylor's Fork to Central Park, Montana.

GRAVES CREEK (Tributary to Tobacco River) - from where Graves Creek intersects the eastern township line of Township 35 North, Range 26 West, to its confluence with the Tobacco River.

JEFFERSON RIVER - from its confluence of the Beaverhead and Ruby Rivers to the Jefferson's confluence with the Missouri River.

KOOTENAI RIVER - from the Canadian line to the Idaho state line.

LITTLE MISSOURI RIVER - from its confluence of Cottonwood Creek to the South Dakota state line.

LOLO CREEK - from the mouth of Tevis Creek to Lolo Creek's confluence with the Bitterroot River.

MADISON RIVER - from the confluence of its west fork to Varney, Montana.

MARIAS RIVER - from its confluence with the Missouri River to a point five miles upstream.

MISSOURI RIVER - from its headwaters at Three Forks, Montana to the North Dakota state line.

NINE MILE CREEK (Tributary to the Clark Fork River) - from the southeast corner of Township 17 North, Range 24 West, to its confluence with the Clark Fork River.

ROCK CREEK (Tributary to the Clark Fork of the Yellowstone) - from the main fork of Rock Creek to Red Lodge, Montana.

SHEEP CREEK (Tributary to Smith River) - from the mouth of Deadman Creek to its confluence with the Smith River.

SMITH RIVER - from the mouth of Sheep Creek to its confluence with the Missouri River.

SOUTH FORK DUPUYER CREEK (Tributary to Dupuyer Creek and Marias River) - from the basins above the canyon to the mouth of the canyon, a distance of approximately eight miles.

STILLWATER RIVER - from upper Stillwater Lake to its confluence with the Flathead River.

SUN RIVER - from the confluence of the north and south forks of the Sun River to its confluence with the Missouri River.

SWAN RIVER - from and including Swan Lake to its confluence with Flathead Lake.

TETON RIVER - from the confluence of its north fork to its confluence with the Marias River.

TOBACCO RIVER - from the mouth of Graves Creek to its confluence with the Kootenai River.

TONGUE RIVER - from the south line of Township 2 South, Range 44 East, to its confluence with the Yellowstone River.

WHITEFISH RIVER - from, and including, Whitefish Lake to its confluence with the Stillwater River.

YAAK RIVER - from the mouth of Fourth of July Creek to its confluence with the Kootenai River.

YELLOWSTONE RIVER - from Emigrant, Montana to the North Dakota state line.

Waters considered Navigable by the Army Corps of Engineers in the State of Montana

KOOTENAI RIVER - From the International Border between the United States and Canada downstream to Jennings Rapids near Jennings, Montana.

MISSOURI RIVER - From its Headwaters near Three Forks, Montana downstream to the North Dakota Border

YELLOWSTONE RIVER - From Emigrant, Montana downstream to the North Dakota border.

WATER RIGHTS

Diversion and Appropriation

Under Montana Statute, surface or groundwater can be appropriated for beneficial uses with a water right. Water is “appropriated” with structures, facilities, or methods used to divert, impound, or collect water. Examples may include a dike, dam, weir, ditch, headgate, infiltration gallery, pipeline, pump, pit, or well. Structures that appropriate water require both a beneficial use and in most cases, an associated water right. Water rights are administered by the DNRC and the Montana Water Court.

Beneficial uses include agricultural, stock water, domestic, fish and wildlife, industrial, irrigation, mining, municipal, power, and recreational uses. Beneficial Use also includes specific instances of instream flow to protect, maintain, or enhance streamflows to benefit the fishery resource.

Prior Appropriations Doctrine: “First in Time is First in Right”

Water rights are granted a priority date based on the filed claim, documented historic use, or adjudicated priority date. Earlier dates are “senior” to later claims or “junior” users. In the event available water is limited, senior users have priority and junior users must cease water use. Senior users can make “call” to exercise their rights. Many streams and rivers are “over-appropriated,” and water rights claims exceed water supply during low flow. Such situations are often administrated by a water commissioner.

Water rights typically have a defined point of diversion, place of use, flow rate, and period of use. Volume may also appear on rights associated with reservoir or ponds. Water rights must be exercised consistent with the permitted or adjudicated use.

New Appropriations

Many basins in Montana are closed to new appropriations of surface or groundwater. In most cases, opportunities to appropriate “new” water are limited by competing existing claims, water availability, and by statute (i.e., basin closures). Exceptions to this exist, including small individual private wells that serve a household. These wells require a 602 certificate, or “Notice of Completion”, which can authorize up to 10 ac-ft/yr and 35 gpm (subject to future changes) for domestic and lawn/garden use. The 602 can also be used for small excavated ponds which use groundwater.

The process for larger appropriations employs the 600 permit. This involves a detailed analysis of physical and legal water availability, potential for adverse impact to other water users, etc. In general, permits for larger “new” water uses are limited in closed basins except in certain circumstances. Examples might include “non-consumptive” use such as ground source heat pumps.

Form No. 606 IR (R 10-2019)



**APPLICATION TO CHANGE
AN EXISTING
IRRIGATION WATER RIGHT**

FILING FEE - \$900.00

FILING FEE REDUCTION
If you attend a pre-application meeting with DNRC staff and your application is submitted within 6 months of the meeting date, the filing fee will be reduced by \$200.00. The time period may be extended if measurements or an aquifer test is required.

Use this application to change the point of diversion, place of use, purpose of use, and/or place of storage of an existing irrigation water right. Attach additional sheets if necessary. Attachments must be labeled as shown in the sections below.

ADDENDUMS THAT MAY BE NEEDED

- Water Marketing
- Historical Water Use
- Instream Flow
- Purpose
- Place of Storage
- Salvage Water
- Temporary Change
- Sage Grouse Review
- Aquifer Testing Addendum

Form 606 is used to make changes to existing irrigation water rights, for example, from irrigation to in-stream flow.

WATER RIGHTS *(continued)***Change Applications**

Converting water use from one type to another (e.g., irrigation to a recreational pond) requires a formal change application. Change applications are administered by DNRC and are required when changing the type of beneficial use, or other elements of the water right such as location of use, point of diversion, or place of storage. The change application process is intended to insure proposed water use is consistent with historic consumptive use and does not cause adverse effects for existing water users. The process first requires review of the underlying right to verify existing water use.

Because many basins are closed to new appropriation, the change application process is used to convert existing water uses to new purposes. For example, a large subdivision might convert irrigation rights to domestic uses, and retire the previously irrigated acres. The same principle applies to instream flow leases, where irrigated acreage is retired in exchange for instream purposes. Notably, change applications cannot increase consumptive use, or protect more than consumptive use. For example, a 10 acre flood-irrigated field that required 80 ac-ft to flood, with 20ac-ft of evapotranspiration by crops would be limited to 20 ac-ft of consumptive use that could be transferred to a new use.

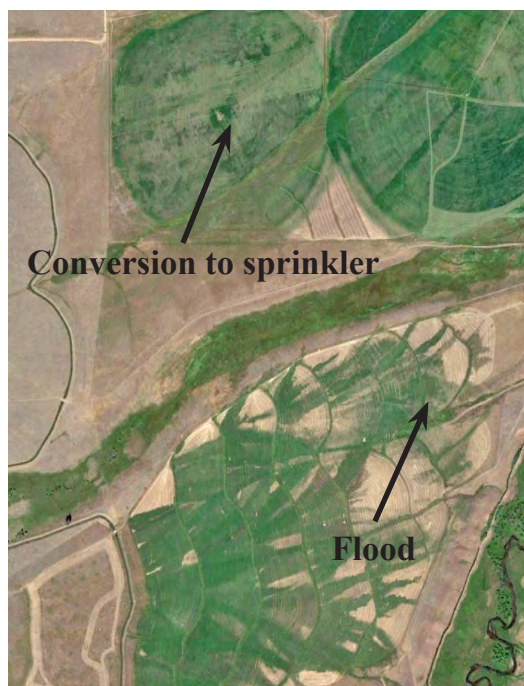

Conversion from flood irrigation to sprinkler does not require a change in water right.

Potential Exemptions: When is No Water Right Needed?

Some exemptions exist for use of water without a water right.

- Stream restoration projects including beaver mimicry that impounds < 0.1 ac-ft of water are exempt.
- Wetland restoration projects that do not increase consumptive use are exempt, but constructed/created wetlands that expand water use are not exempt.
- Watering riparian/streambank vegetation to establish new plantings may be exempt, but watering new lawns or crops is not.
- Emergency use for fire suppression is typically exempt.

These exemptions are subject to change, and water users are encouraged to discuss their proposed activity with DNRC water rights staff.

CAUTION

- Existing water uses are protected by Montana statute and any changes to historic use need to be carefully evaluated to ensure other water users are not adversely impacted.
- Changes to existing water rights and water management practices need to be reviewed by DNRC through the change application process.

FISH STOCKING PERMIT

Fish Stocking

Fish stocking of a private pond may legally be undertaken only after a Non-Commercial Private Fish Pond License has been issued by MFWP.

A private pond is defined as “a body of water created by artificial means or by a diversion of water that does not exceed 500 acres of surface area.” (MCA 87-4-603).

A private pond “does not include all other natural ponds or bodies of water, including streams or rivers and impoundments or reservoirs of or on a natural stream, river, lake, or pond.”

Public and Private Waters

Natural waters are public waters in Montana, and a private pond owner may not restrict the public use of them. Further, the law is meant to prevent the damming of natural streams on private property that can harm stream habitat, interfere with fish migration, and result in ponds ultimately filling with sediment.

If a pond meets certain requirements, the owner of the pond may qualify for a fish stocking license. This allows the pond owner to “stock the fish pond with” approved fish species “procured from any lawful source” and to “take fish from the lake or pond in any manner.” State fishing regulations and licenses are not required to take fish from a private pond.



A fish stocking permit may require use of native species such as cutthroat trout.



Natural water bodies, especially those connected to perennial streams, may be considered public waters by Montana statute.

*FISH STOCKING PERMIT (continued)***Permit Considerations**

A Non-Commercial Private Fish Pond License must be obtained from MFWP before fish can be procured or stocked:

- MFWP will designate which fish species may be planted.
- MFWP may condition the license regarding fish barriers, if they are deemed necessary.
- There is a \$10 application fee that must be paid to initiate the review process.

Proof of a water right appropriate for the size and location of the pond will be required prior to issuing the Non-Commercial Private Fish Pond License.

- For existing ponds that have a valid Reservoir Record from DNRC and a priority date prior to January 1, 2000, a private pond permit can be issued without a specific “fishery” or “fish and wildlife” purpose.
- For ponds with a water right priority date of January 1, 2000 or later, the water right must include a “fishery” or “fish and wildlife” purpose to obtain a fish pond permit.
- Any impoundment created via the “stockwater exemption” in the Water Use Act (85- 2-306(3), MCA) must obtain a new water right for fishery purposes if the stockwater exception was issued January 1, 2000 or later.



Inlets and outlets of ponds connected to perennial streams may require screening to prevent escapement of stocked fish, or capture of fish from the stream.



Groundwater ponds with no inlet or outlet, or not located in the floodplain, may have more lenient stocking requirements than ponds in the floodplain or connected to streams with diversion ditches.

CAUTION

- Ponds should not impound perennial streams, and should be located away from the stream channel. Ponds located in the floodplain will have additional permitting requirements, and may have limitations on stocking.
- Ponds may need emergency spillways if flooding could occur.
- Ponds may need fish barriers in inlet and outlets to prevent capture or escape of fish.
- Groundwater ponds without inlets and outlets may not need fish barriers or emergency spillways.
- Aquatic nuisance species can be a threat to ponds and adjoining natural waterbodies.
- Pond stocking permits are reviewed by a local MFWP biologist and the applicant should plan to coordinate with agency staff.

SUMMARY OF PERMITTING EXPECTATIONS AND PROCESS

Design requirements depend upon the granting agency and expectations, which may vary according to local policy. In all cases, stream project designs must be sufficiently complete to demonstrate the probability of success and any potential impacts of the proposed project. Engineered designs may be required, especially for larger scale, complicated, or intensive projects that may have potential impacts.



Management of fill in wetlands and floodplains is important to permitting agencies.

For all stream project permitting, a detailed description of the proposed work should include, at a minimum:

- Description of the existing condition and rationale for proposed work
- Site map or drawing, including legal location
- Dimensions of site where work is proposed (use the high water mark, if known as a point of measure)
- Quantities and types of materials (rock, trees, gravel, erosion fabric, etc.)
- Construction techniques, including equipment used
- Where excavated material will be placed
- Revegetation and weed management plans
- Timing of proposed work
- How impacts to fish and aquatic habitat will be minimized
- How impacts to the channel, erosion, sedimentary effects on water quality and stream flow, and the risks of flooding will be minimized
- Expected benefits of the work, including the natural environment and any infrastructure protection needs
- Names and addresses of adjacent landowners

A complete description of all proposed work is important, because any construction activity not explicitly described in the permit, in writing may be considered to be a violation of the permit conditions.

The Montana Streambed and Land Preservation Act (310 Permit) permitting process requires the project to be effective for the intended purpose and protective of the natural streambed and banks. The 310 process is not intended to provide technical design review, certification of designs, or substitute for engineering expertise. A site visit by Conservation District members is generally required to review proposed work.

Section 404 of the Clean Water Act (404 Permit) focuses on wetland and stream channel disturbance, including placement of fill materials. USACE 404 permits are required on many stream projects requiring a 310 permit, and also include many projects adjacent to the stream channel or in the floodplain which may not require a 310 permit. Many smaller stream or river projects fall under the streamlined 404 “nationwide” permitting system, which expedites processing of the application. Stream projects in excess of 300 linear feet may require mitigation under the Montana Stream Mitigation Procedure (MSMP).

SUMMARY OF PERMITTING EXPECTATIONS AND PROCESS (continued)

Section 10 of the Rivers and Harbors Act of 1899 (Section 10 Permit) requires a permit prior to the accomplishment of any work in, over, or under navigable waters of the United States, or which affects the course, location, condition or capacity of such waters.

The Floodplain Development Permit is the local extension of FEMA policies that are intended to minimize flood damage with floodplain developments. Floodplain development permits may require engineered design to ensure certain criteria are met, such as stability in a 100-year flood, demonstration of no adverse impacts up or downstream, and analysis of effects on elevation of a 100-year flood.

The Short-term Turbidity (318 Permit) focuses on ensuring that proper sediment control measures are taken during construction to minimize impacts to water quality. Requirements are generally satisfied by the 310 permit for smaller projects that release minimal sediment to the stream. A separate 318 permit should be obtained for projects that have the potential to release substantial amounts of sediment during construction.

Montana Pollutant Discharge Elimination System (MPDES) Permit considers water quality and sediment control on construction sites, and seeks to ensure that proper measures are taken to minimize potential impacts to surface water. Construction projects that have site disturbance near surface water, or that could discharge runoff to surface water, may require the MPDES permit. At a minimum, the permit requires a site drainage control plan with approved practices to minimize potential erosion and runoff from the site.

The Montana Stream Protection Act (124 Permit) requires projects to protect Montana's fishing waters such that they remain for all time in their natural existing state, except as may be necessary and appropriate after due consideration of all factors involved. Project applications are generally followed by a site visit by the local fisheries biologist. The permit includes requirements to protect fish and wildlife habitat.



Construction activities on the bed and banks of perennial streams generally require both state and federal permits. No floodplain permit was required for this project.



Channel reshaping or placement of fill within the active floodway (including woody debris) normally requires a floodplain permit in FEMA floodplains.

STORMWATER AND EROSION CONTROL BMPs FOR CONSTRUCTION

Construction Planning and Best Management Practices (BMPs)

Efficient project planning can greatly reduce sedimentation by 1) reducing the project duration, 2) reducing the number of times machinery enters channel, 3) reducing overall site disturbance, and 4) identifying appropriate BMPs for sediment control.

All projects should seek to:

- Minimize site disturbance
- Preserve existing vegetation as much as possible
- Use erosion control measures (hay bales, silt fence, drainage features, etc.)
- Reseed disturbed areas
- Minimize the spread of invasive aquatic species by cleaning and drying equipment before and after mobilization



Dewatering construction areas with pumps requires a MPDES permit when discharging to State waters.

Sediment Control is Water Control

Avoid excavation in flowing water. Even gravelly substrates can release substantial amounts of fine sediment during construction. Dewatering options may include:

- Isolating the work site with barriers (e.g., berms, tarps, coffer dams, sheet pile)
- Rerouting the channel around the work site
- Dewatering with pumps, or diversion into irrigation ditches

Dewatering a construction area requires a discharge permit (MPDES) to release discharge to surface water. Turbid water generally must be filtered through sediment retention structures prior to release.

Construction Timing

On river projects, the best construction time is generally during low flows in mid-summer, and sometimes in mid-winter when the ground is frozen. Fisheries and recreational concerns may restrict construction windows.

Construction activities with the potential to release fine sediments or dewater channels should be planned to avoid disturbing spawning fish and egg incubation. Both spring and fall periods may have spawning runs depending on fish species in the drainage. State and federal fish biologists can make recommendations during the permitting process. Construction timing may also need to consider impacts on recreational use, such as rafting or fishing.

STORMWATER AND EROSION CONTROL BMPs FOR CONSTRUCTION (continued)

Construction BMPs - Aquatic Invasive Species

Aquatic and terrestrial invasive species can be spread by construction equipment. Site disturbance makes new construction areas especially vulnerable to establishment of invasive species. Clean all mud and plant material from construction equipment, trailers, etc. preferably by power washing equipment prior to mobilization to the new construction site.

Aquatic invasive species of particular concern include Zebra and Quagga mussels, whirling disease, and the New Zealand mudsnail. Terrestrial and aquatic weed species include leafy spurge, knapweed, thistle, purple looserife, Eurasian water milfoil, and others. Proper cleaning of equipment helps limit the spread of these species.

WORKING WITH A LANDOWNER'S REPRESENTATIVE(S)

Stream permit applications are often submitted by the landowner's representative: a consultant or construction contractor. This person may not actually perform the project work, and the **landowner is ultimately responsible for the permit**.

It is therefore imperative that the landowners sign the permit application, authorizing the consultant or contractor to represent them. The decision form must also be signed by the landowners to ensure that they agree to construct the project as permitted. All permit correspondence should be sent to both the landowners and their representative throughout the permitting process to ensure that the landowners receive all pertinent information.

A consultant, construction contractor, or engineer is often hired to design and oversee a proposed project. This person may be directly involved in the entire permitting process and implementation phase. However, for any of several reasons (costs, timing, etc.), landowners may change consultants or contractors during the process, or may plan to do the actual construction work themselves.

Out-of-state landowners typically hire a realtor to obtain the needed stream permits as a service to them. In these cases, the realtor's involvement usually ends here, and he or she will not be involved in the project construction stage.

WORKING WITH UTILITY COMPANIES

When a utility company applies for a stream permit, the landowner's signature is not necessary because the company will obtain a legal right-of-way from the landowner before beginning project construction.

STREAM FORM AND FUNCTION

Streams and rivers are complex and dynamic (constantly changing) systems with a fundamentally basic function – to move **water and sediment** efficiently from the upstream watershed to points downstream. Despite this seemingly simple function, the processes by which streams maintain an efficient system of water and sediment delivery can seem complex and difficult to understand. The perpetual change to maintain this efficiency is known as **dynamic equilibrium**.

Understanding channel processes is important so that we are able to infer the cause and effect of channel change, and if warranted, to implement projects that work with the natural channel processes to maintain or improve the balance inherent to the system. Designing projects to work with the natural channel processes offers potential long-term benefits to both the landowner and to the stream system. Understanding opportunities, potential limitations, and probable outcomes of a range of project alternatives requires considering stream form and function.

Stream morphology (form) and stream processes (function) are closely related. The goal of this chapter is to introduce stream morphology (often referred to as **channel form** – or the physical expression of the stream on the landscape) and the interrelated stream processes (**stream function** – or the mechanisms by which the channel moves water and sediment) that allow for interpretation of the natural and anthropogenic influences that may be affecting both the form and function of stream channels.

Contents

Watersheds	2.2
Geology And Climate.	2.3
Stream Channel Form	2.4
Bank And Channel Stability.	2.8
Flow Characteristics	2.10
Field Indicators of Bankfull Flow	2.11
Channel Downcutting & Re-Establishment of Equilibrium.	2.12
Channel Migration Zones	2.13
Meander Movement and Bank Erosion	2.14
Role of Large Woody Debris	2.16
Role of Beaver Dams	2.17
Case Study - Big Spring Creek	2.18

WATERSHEDS

A **watershed** is an area of land bounded on all sides that drains to a specific outflow point, such as a lake or a larger stream. The land that drains water to that outflow point is the watershed for that location. The confluence of streams and rivers is the point at which the area of a watershed expands. A watershed may consist of surface water including lakes, streams, and wetlands as well as the underlying groundwater. Watersheds can range in size from a small headwater tributary to the Missouri River drainage, Montana's largest watershed. A larger watershed is made up of several smaller watersheds. Hydrologic Unit Codes (HUC) are one way that watershed sizes are classified.

A watershed collects, stores, and transports water, sediment, and organic material that shape and define the streams and rivers within them.

- Water - From precipitation and stored in snowpack, groundwater, and vegetation until it evaporates from the ground, transpires through vegetation, or flows downstream in the form of channel runoff
- Sediment - From the upland ground surfaces and streambanks during rainfall or snowmelt runoff, deposits on pointbars and floodplains
- Organic material - From plants and animals across the watershed, provides nutrients for aquatic life and structure to stream channels in the form of large woody debris

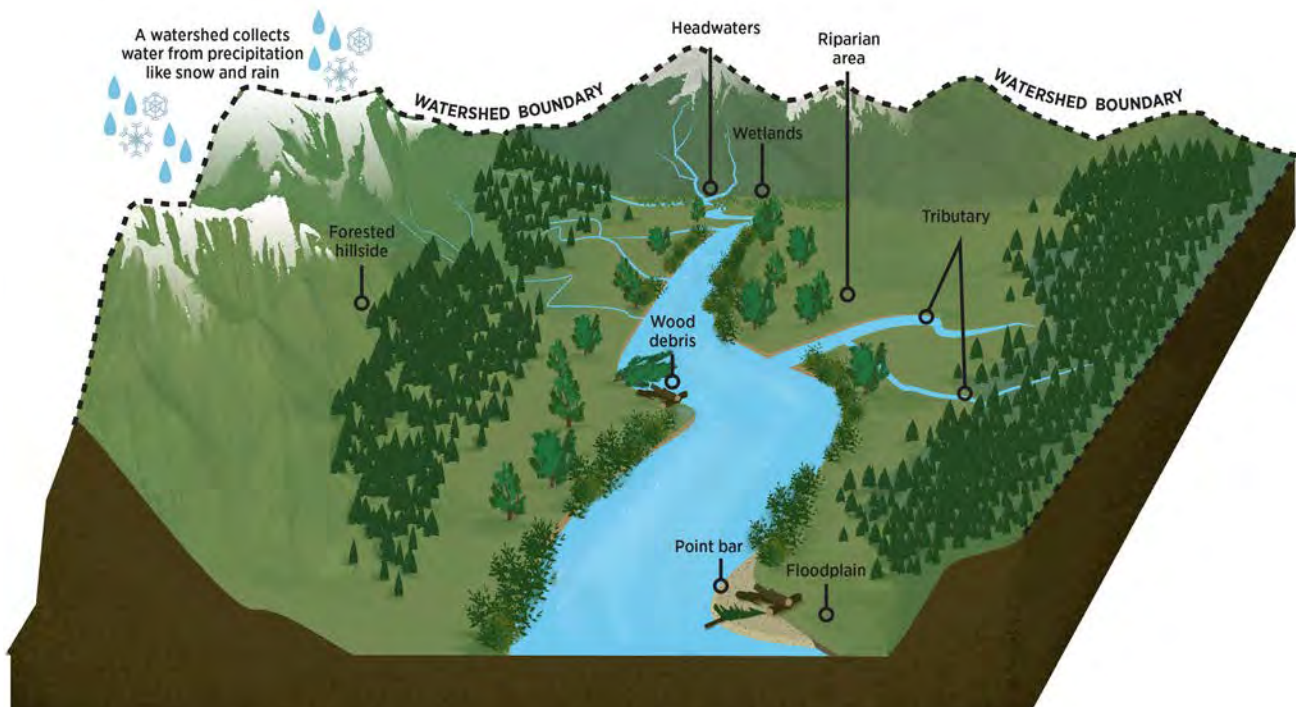

GEOLOGY AND CLIMATE

Average Annual Precipitation

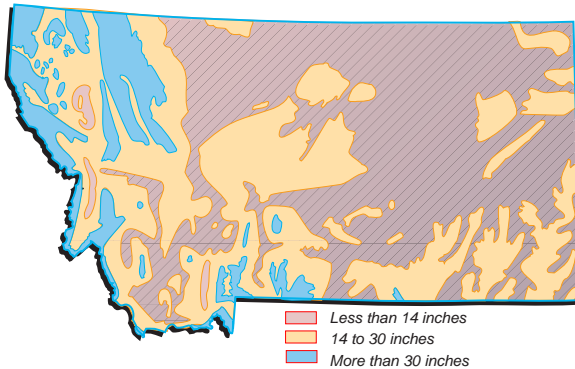

Average Annual Runoff

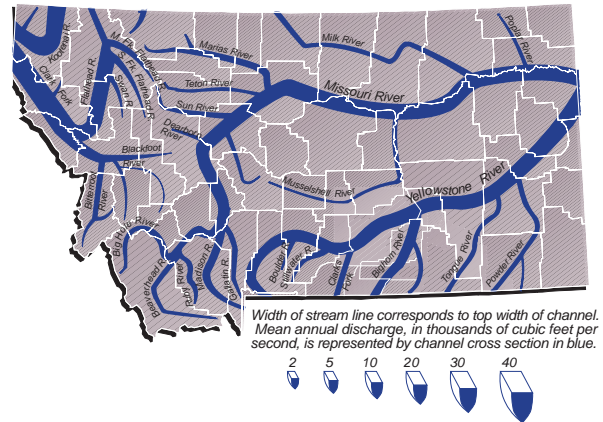

Montana is a fairly arid state, with much of the precipitation falling in the form of snow. Spring runoff from melting snow drives a lot of channel forming processes

Higher precipitation west of the continental divide results in more water flowing out of the state annually in the Clark Fork than in the Missouri River.

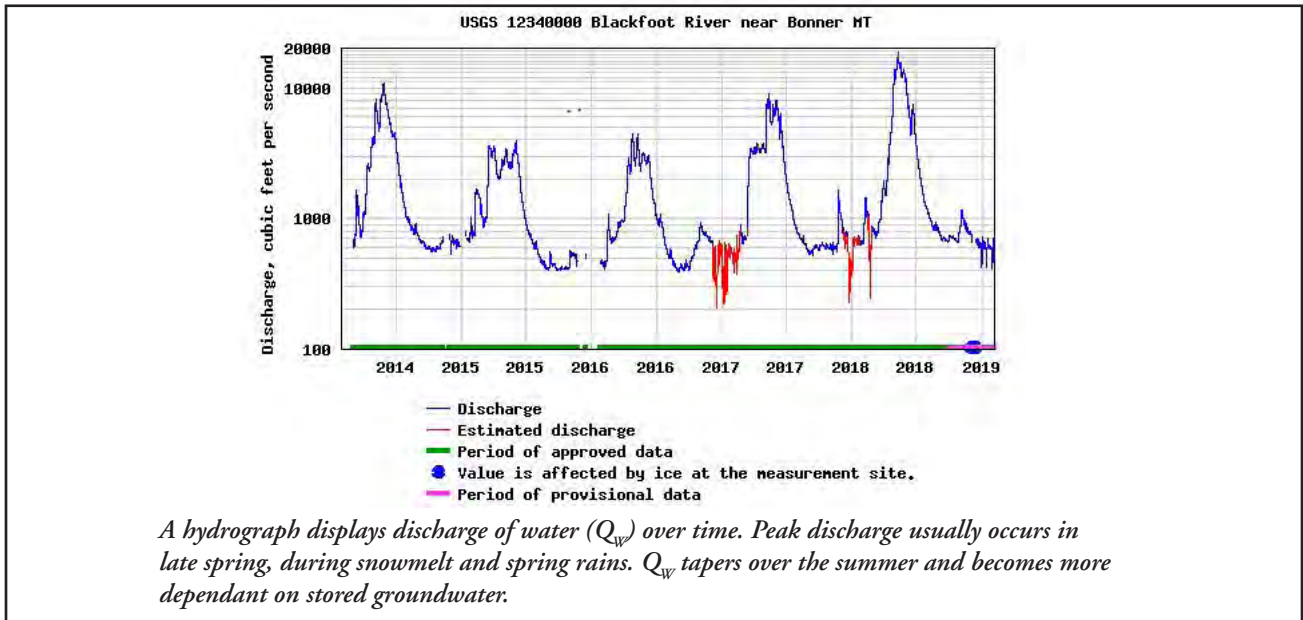

A hydrograph displays discharge of water (Q_w) over time. Peak discharge usually occurs in late spring, during snowmelt and spring rains. Q_w tapers over the summer and becomes more dependant on stored groundwater.

Stream channels are formed by the flow of water and sediment delivered from its watershed.

Streamflow is controlled by local climatic conditions and weather events, primarily by the amount of precipitation that falls in a watershed as rain or snow. Much of the streamflow in Montana occurs in late spring and early summer when snow melts from high elevations. These spring runoff events also move a lot of sediment and debris that drive channel form. The majority of precipitation that falls in a watershed flows out. However, some is lost to evaporation and transpiration and some is stored in groundwater, wetlands, or manmade reservoirs. The release of stored water can have significant effects on streamflow during the late summer months.

Underlying geology within a watershed dictates the path of flow, streambed and streambank material, rates of erosion, and permeability of soils. Land cover and land use dictate the quality and quantity of water leaving a watershed.

STREAM CHANNEL FORM

Channel form is not static but maintains a dynamic equilibrium that is in balance with its water and sediment supply. It is influenced by watershed characteristics and its location within the watershed. Healthy streams are characterized by a stable but often dynamic channel, a floodplain that is inundated at regular high flows (bankfull), and streamside (riparian) vegetation.

Streams with higher gradient (>4%) tend to have a narrower floodplain, straighter channel, and stability maintained by large sediment (boulders and cobbles) and underlying geology (bedrock).

Streams with lower gradient (<2%) tend to have broad floodplains, sinuous and dynamic channels, and deep rooted riparian vegetation (e.g., willows or sedges) to maintain long-term stability. Over time channels will naturally move across their floodplain eroding outside bends and depositing sediment on inside bends (point bars). Streambank erosion increases due to factors such as removal of riparian vegetation and changes to channel pattern (e.g., channelization).



Low gradient streams meander across their floodplain over time. “Meander scars” provide evidence of past channel migration across its floodplain, where the old channel has filled in over time.

High gradient streams have narrower floodplains, transporting sediment and debris to the lower watershed.



STREAM CHANNEL FORM

Dimension, Pattern, and Profile

Stream channel form is dictated by processes including the water and sediment discharge as well as the geologic setting. Channel form develops and maintains a dynamic equilibrium that is dictated by the supply of water, sediment, and debris from its watershed. Channel form is often expressed in three primary measures:

- **Dimension:** Displayed as a cross section view of a stream, this characteristic illustrates water depth at different stages relative to streambank height.
- **Pattern:** Displayed in plan view (from above), this characteristic illustrates a stream's sinuosity or length within a valley. Also referred to as planform.
- **Profile:** Displayed as a view of the average dominant slope range along the bankfull water surface or as a more detailed measurement of the stream bottom depth relative to bankfull water surface.

Rosgen stream types are a useful way to discuss stream and river systems defined by these three characteristics. Typical Montana streams begin high in steep mountain terrain as A type channels, gradually transitioning to B and then C channels as they reach the valley bottom. Significant training is necessary to accurately classify stream types; however, a general understanding of dimension, pattern and profile can help understand how a stream may function. A complete description and examples of Rosgen stream types can be found in Appendix 1.

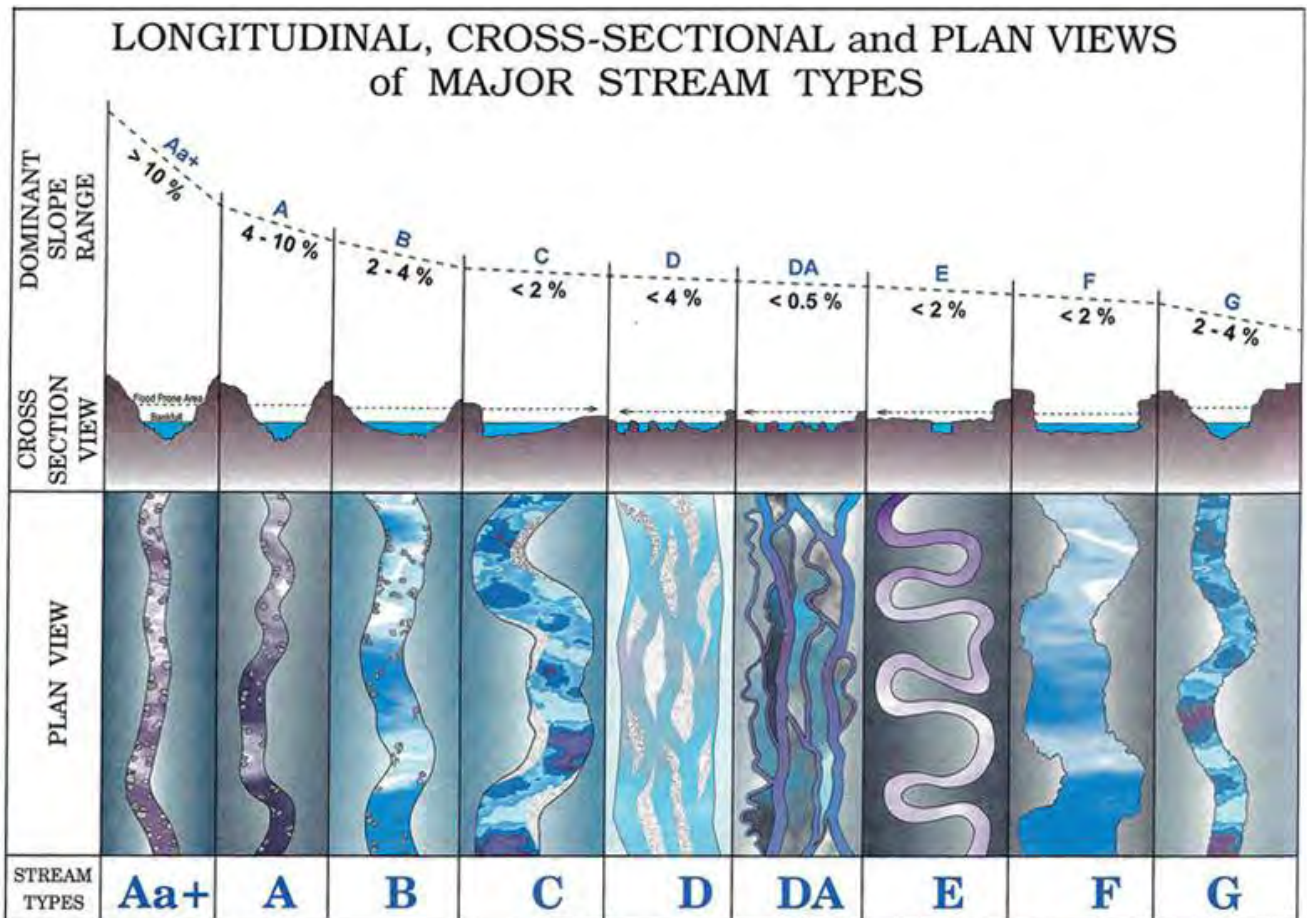

THE LANE DIAGRAM

Lane's Diagram – Don't Leave Home Without It!

Lane's relationship shows stream process is a function of four main factors:

- Sediment discharge (Q_s)
- Sediment particle size (D_{50})
- Streamflow (Q_w)
- Stream slope (S)

Lane's relationship suggests that a channel will be maintained in dynamic equilibrium when changes in sediment load and bed-material size are balanced by changes in streamflow or channel gradient. A change in one of these factors causes changes in one or more of the other variables, in this way a stable form tends to re-establish.

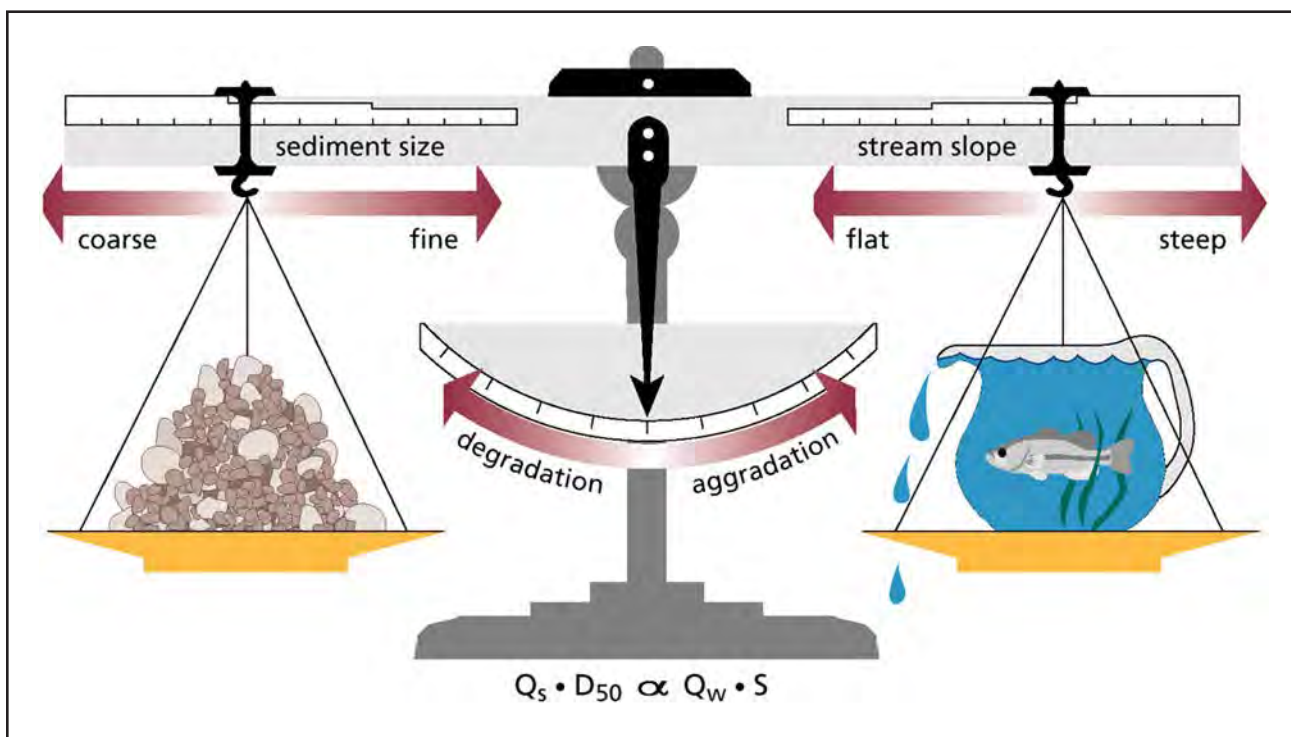

A large amount of sediment is being added by a 30-foot high bank (below the trees).

How has the stream adjusted?

1. Aggraded the meander (add more sediment to scale).
2. Steepened slope with meander cutoff (slide stream slope to right).

These adjustments are part of the river's way of finding balance as described in the Lane diagram.

APPLYING THE LANE DIAGRAM

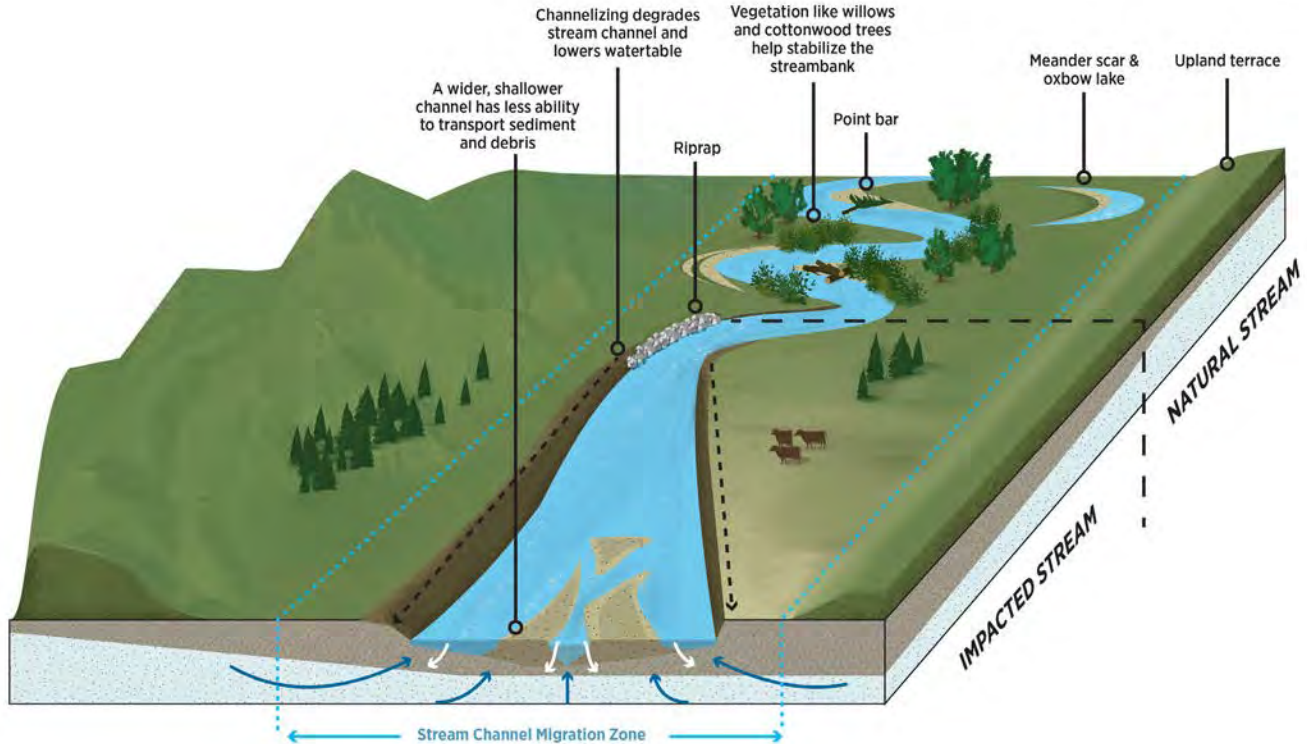

Lane's Diagram – Examples of its Application

Channel is straightened to increase agricultural production.

- Stream slope is now steeper due to loss in stream length
- Steeper channel moves larger sediment causing degradation or downcutting
- Water cannot access the floodplain during high flow due to downcutting causing increased bank erosion; groundwater level is lowered
- Excess fine sediment from bank erosion accumulates downstream where channel is less steep, causing the downstream channel to aggrade
- Aggradation leads to more downstream bank erosion

Changes in stream flow. Water is diverted year round.

- Less water in the channel reduces the power to move sediment downstream leading to aggradation
- Aggradation leads to bank erosion and channel widening

CAUTION

Maintaining riparian vegetation and stream channel connection to its floodplain are critical for ensuring long-term dynamic channel stability.

BANK AND CHANNEL STABILITY

Dynamic Equilibrium and Channel Stability

Maintaining the balance

A stable channel transports the flows and sediment in such a manner that the dimension, pattern, and profile of the river is maintained without either aggrading (filling) or degrading (scouring). Stream systems naturally tend towards minimum work and uniform distribution of energy, or “dynamic equilibrium.” This means that changes in channel form (such as bank erosion) can be the stream’s way to maintain balance in water and sediment. Even stable streams move over time, and stream management should accommodate these natural changes.

Sediment transport

Under conditions of dynamic equilibrium, streams balance sediment loads entering a stream reach with those leaving it (sediment/water balance). Imbalance results in either aggradation or degradation. When more sediment enters a reach than leaves it, aggradation will occur as the stream’s transport capacity is exceeded. In contrast, degradation occurs when a stream has excess energy and more sediment leaves a reach than enters it. Bank instability problems are frequently apparent where streams are aggrading or degrading.

Channel shape varies to keep the balance

The ability of a stream to carry its sediment load largely depends on cross-section shape and channel slope. A channel cross section that maintains a stable geometry and channel slope will generate enough force to transport sediment and convey water through the reach. Channel geometry adjusts to accommodate sediment input and discharge.

Land use makes a difference

Stream management can influence how the stream responds to flood events. Both human and natural factors can cause substantial changes in channel stability. Maintaining riparian vegetation is highly beneficial to stream function.



Aggrading (filling) channel reaches can be indicative of streams out of balance. This channel has completely filled with gravel delivered from upstream reaches.



Degrading (scouring/downcutting) channels are common when streams have been straightened.

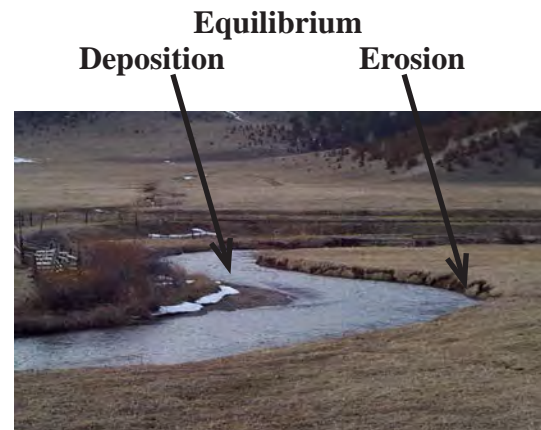

Scour and deposition still occur in equilibrium channels and can be accelerated by removal of vegetation. Note the lack of riparian vegetation on the outside meander.

BANK AND RIPARIAN VEGETATION

Healthy vegetation promotes healthy river channels

Vegetation serves many functions

Riparian vegetation is an integral and important component of a healthy stream environment. Trees, shrubs, grasses, and other plants with deep roots help to stabilize banks, regulate water temperature and nutrient levels, filter sediment, and provide overhead cover and food for fish and other organisms.

Vegetation is crucial in stabilizing some channels

Riparian vegetation along otherwise unconfined stream channels is especially significant for maintaining a stable stream corridor. Streams with high bedload transport rates are very sensitive to upstream changes in water and sediment supply. The channel may move laterally, eroding the banks. Woody vegetation slows lateral channel movement and reduces overbank flood velocities in the floodplain.

Clearing riparian areas is costly

Land management activities that reduce riparian vegetation (such as conversion of riparian to lawns, fields, or livestock grazing) can result in bank erosion even during moderate flows. When this occurs, a series of channel adjustments may lead to a change in channel type, for example from a single threaded channel to a multiple threaded, overwidened, braided channel. Accelerated bank erosion and channel migration are seen in more sensitive channel types.

Good stream management should include a plan for monitoring and eliminating or reducing noxious weeds, while reseeding with native plants to protect against erosion.



Remnant willows are found in many floodplains converted to agricultural uses.



Assisted by rip-rap, a single tree does what it can. Note the absence of mature replacement trees in the floodplain.



Replacement trees are colonizing the expanding point bar floodplain. The channel is moving several feet per year (20+ feet in 1997, alone), much to the dismay of the landowner.

FLOW CHARACTERISTICS

An understanding of both peak flow and low flow conditions is required when designing channels and in-stream structures. In particular, designing river projects around bankfull dimensions is standard practice for alluvial channels.

Discharge and Channel Geometry

Bankfull Discharge

Bankfull discharge is defined as the discharge at which channel maintenance processes are the most effective. That is, the discharge that moves sediment, forms or removes bars, forms or changes meanders, and generally does the work that results in the average characteristics of the channel. The bankfull flow has an average return interval of approximately 1.5 to 2 years, although this number can vary to 1.1 to 2 years or more. In Montana, this primarily occurs during spring snowmelt runoff.

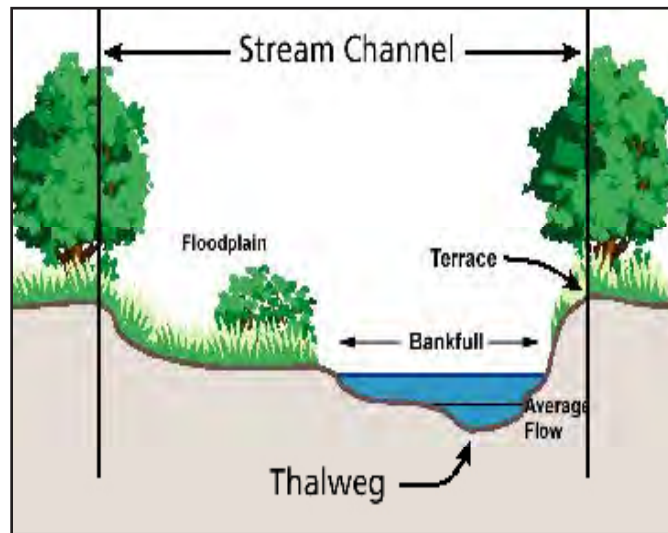

Understanding bankfull dimensions is critical for the design of channel cross sections, culverts, bridges, and other in-stream structures. Projects should be designed to maintain sediment transport and convey water. Replicating stable bankfull dimension of width, depth, and slope will help ensure that sediment transport processes remain in a natural range. Substantial deviation from bankfull dimensions may lead to increased bank erosion, stream bed aggradation or degradation, and structural failure.

The average flood event (usually with a recurrence interval of about 1.5 to 2 years) is associated with channel adjustments, especially in streams with reaches that are not structurally controlled, such as portions of the Bitterroot or Yellowstone rivers. Adjustments may include lateral scour, channel abandonment (avulsion and formation of meander cut-off chutes), pool filling, channel straightening, and local changes in slope.

Estimating flood discharge and bankfull flow can be accomplished using an interactive, online software program by the U.S. Geological Survey called StreamStats. This provides flow estimates for ungaged watersheds using physical basin characteristics including variables such as drainage area, stream slope, mean annual precipitation, percentage of forested area, elevation and other factors. Predictive equations have been developed for eight hydrologic regions in Montana.

Ordinary High Water Mark

Bankfull flow or elevation often corresponds to the “ordinary high water mark”, which is important for jurisdictional purposes. For example, the Clean Water Act 33 CFR 328.3(e) states:

The term ordinary high water mark means that line on the shore established by the fluctuations of water and indicated by physical characteristics such as a clear, natural line impressed on the bank, shelving, changes in the character of soil, destruction of terrestrial vegetation, the presence of litter and debris, or other appropriate means that consider the characteristics of the surrounding areas.

The definition of high water mark may equally pertain to other permitting.

FIELD INDICATORS OF BANKFULL FLOW

USGS Gage Records

Bankfull elevation can be determined from U.S. Geological Survey (USGS) gage station records, through flood frequency analysis and development of hydraulic geometry, or from the following principal indicators:

Point Bar Indicators

Point bars can be used as an approximation of bankfull elevation. The point bar is the sloping surface that extends into the channel from the depositional side of a meander. The top of the point bar is at the level of the floodplain because floodplains generally develop from the extension of point bars as a channel moves laterally by erosion and deposition over time. Depositional, flat features are the best indicator of bankfull elevation.

Vegetation Indicators

The bankfull elevation is usually marked by a change in vegetation, such as the change from point bar gravel to forbs, herbs, or grass. Shrubs and willow clumps are sometimes useful but can be misleading. Willows may occur below bankfull stage, but alders are typically above bankfull. Confirm vegetational indicators with depositional features.

Topographic Breaks

A topographic break is often evident at bankfull elevations. The stream bank may change from a sloping bar to a vertical bank, or from a vertical bank to a horizontal plane on top of the floodplain. Bankfull is often marked by a change in the size distribution of sediment and soil materials at the surface.

Generally, bankfull stage corresponds to the mean high watermark referenced under the state's 310 permit.



The tops of point bars can provide a good indicator of bankfull dimensions in the field.



This bridge stringer is also a good indicator of bankfull. Projects should avoid this situation, which traps debris.



Bankfull is not always obvious and can be difficult to visualize in some channel types.

CHANNEL DOWNCUTTING & RE-ESTABLISHMENT OF EQUILIBRIUM

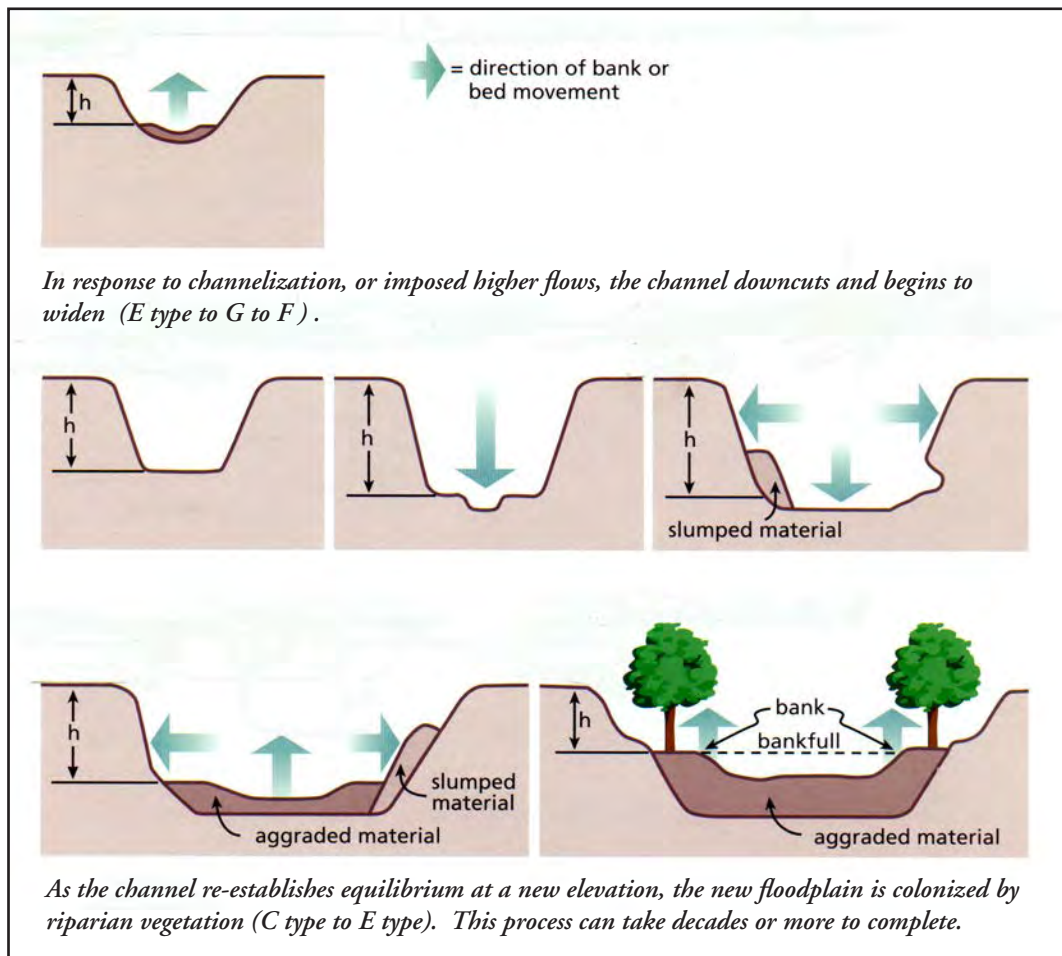

This channel has downcut severely due to excessive flow introduced for irrigation (Rosgen G type).



Downstream in the drainage, a new equilibrium channel with meanders, point bars, and floodplain is beginning to develop (F channel moving to C).

CHANNEL MIGRATION ZONES

The area within which a river channel is likely to move over a period of time is often referred to as the channel migration zone (CMZ). The migration of river channels includes processes of lateral scour/deposition, avulsions, and sometimes erosion of terraces. CMZs are related to floodplain mapping.

A Channel Migration Zone is composed of:

- Historic Migration Zone (HMZ) – the area of historic channel occupation, usually defined by the available photographic record. This can be thought of as the cumulative footprint of the channel as seen in available historic imagery.
- Erosion Hazard Area (EHA) – the area outside the HMZ susceptible to channel occupation due to channel migration or mass wasting. This is the area that, based on historic rates of migration, the river may occupy over the period of the CMZ.
- Avulsion Hazard Zone (AHZ) – floodplain areas geomorphically susceptible to abrupt channel relocation. These are often swales, historic channels, or bendways that are not captured by the EHA.
- Restricted Migration Area (RMA) – areas of CMZ isolated from the current river channel by constructed bank and floodplain protection features (also known as the Disconnected Migration Area, or DMA)

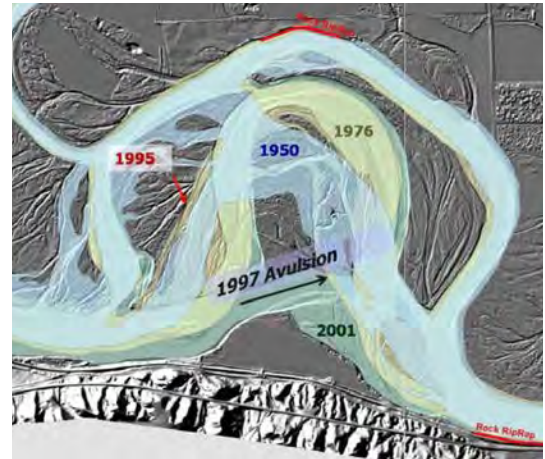

The Yellowstone River is particularly active within its floodplain. Channel migration studies are being developed for the Lower Yellowstone and Lower Missouri, among other locations.

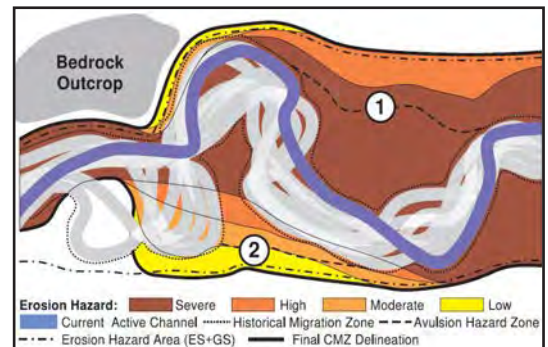

Zones of varying risk are defined based on historic channel patterns, topography, and floodplain characteristics.

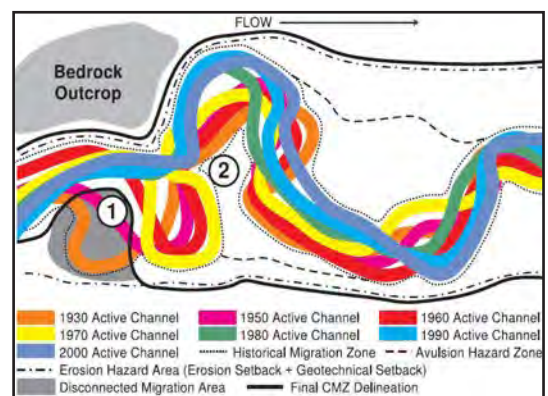

Delineation of historic patterns of channel plan form helps define the CMZ.

Considerations for Project Design

- Maintain the natural process of channel migration. Restriction of floodplains, and encroachment/development within CMZ can have unintended negative consequences for landowners and adverse impacts to river systems.
- Channel and project design should take into consideration location within the CMZ, and endeavor not to impair or encroach on natural processes in a manner that will cause adverse impacts.

MEANDER MOVEMENT AND BANK EROSION

Meanders evolve naturally over time

Meandering channels in rivers systems naturally evolve shape and position in the floodplain. The relative stability of meanders is a result of both environmental and often human factors. Meanders shift position in response to changes in the sediment supply/water balance, impacts from upstream reaches, land use such as grazing or clearing of floodplain vegetation, and large scale channel adjustment related to changing environmental conditions. Healthy riparian vegetation provides bank stability and slows channel migration.

Meanders move downstream

The highest erosive forces are typically at the lower third of the meander. This causes the meander to migrate in the downstream direction. To the observer standing at a fixed point downstream, this may appear that the bank is eroding laterally when in fact the meander is simply displacing its shape in the downstream direction. In other cases, meanders may develop in a manner that shifts laterally across the floodplain.

Restoration is sometimes possible

If causes of bank instability and meander movement are localized and due to site specific factors such as loss of riparian vegetation, restoration using bioengineering methods that emulate and restore natural conditions may be appropriate. If meander movement and channel adjustments are system wide, or within the range of natural variability, restricting meander movement may have negative consequences on river function.

Let nature take its course

Understanding meander development and underlying causes is important to develop appropriate treatments, if any. In many cases, the “no action” or passive treatment (e.g., riparian protection, setbacks) may be the best alternative to maintain river function.

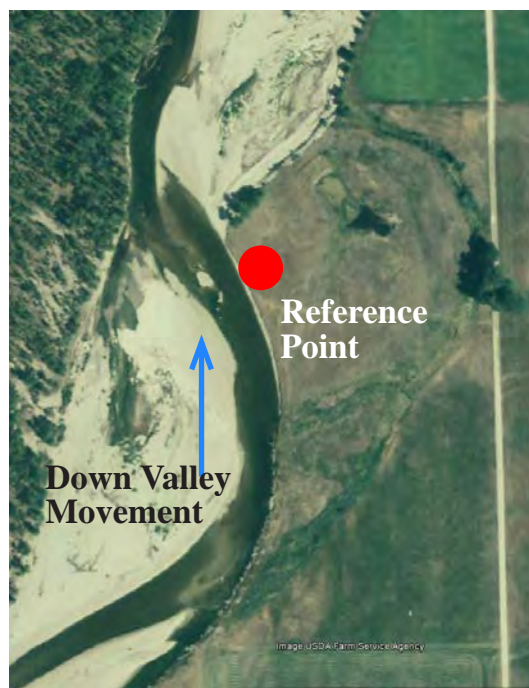

Bitterroot River meander 1995 eroding bay field on right bank.



Bitterroot River meander (2014) has moved several hundred feet downstream and laterally over 20 years.

CHANNEL CUTOFF (AVULSION)

Channel cutoff is a common process in alluvial channels

Highly sinuous, meandering streams often form fairly stable channels. Floodplain and bank vegetation is key in maintaining stability. Natural channel migration occasionally cuts a meander, forming an abandoned oxbow. Meander “cutoffs” are a natural part of stream channel process, but can be accelerated by poor stream management. Extensive rip-rap to constrain the channel may lead to meander cutting up or down stream. Removal of beaver can also increase the probability of meander cutting.

Sediment sources are important

Excess sediment from upstream erosion contributes to meander cutoffs. Many meanders are cut off because stream energy is insufficient to carry incoming sediment through a bend. When a sediment plug forms at the entrance to a meander bend, the stream may cut through the floodplain or point bar.

Restoration requires balancing sediment and stream flows

When a meander is abandoned, the channel responds by increasing its slope, velocity, and its ability to carry sediment. This may cause accelerated bank cutting and erosion downstream. In some cases, a stable meander pattern can be re-established, but only after developing a strategy to balance sediment and water transport through the reach.

Let nature take its course

In most cases, allowing natural meander cutoffs to occur without intervention may be the best strategy for ensuring long-term river health. Meanders evolve and “age” as a natural adjustment. Although it is not always easy to determine what “natural” is, it is seldom wise to work against a river’s natural process.

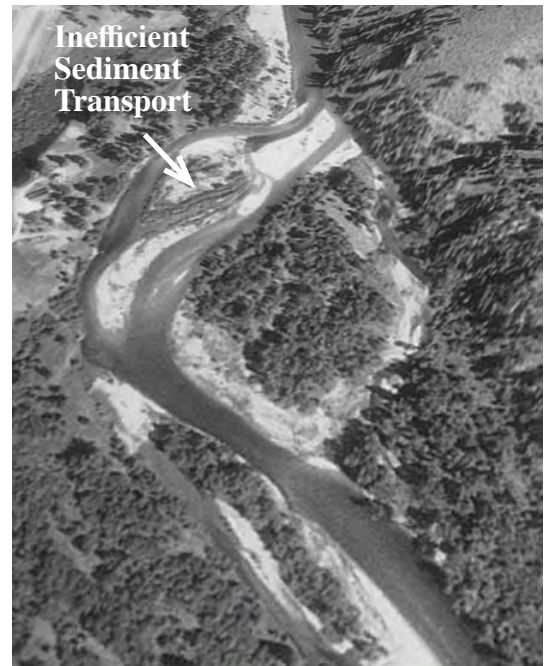

Bitterroot River meander in 1995 showing sediment deposition in left channel.

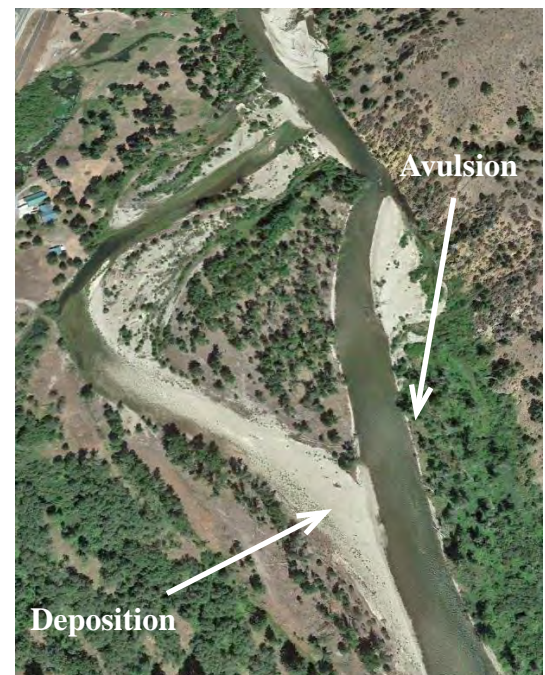

Bitterroot River channel cutoff in 2014. Sediment has deposited on the left meander channel. Note rip-rap in left channel to protect home.

ROLE OF LARGE WOODY DEBRIS

In addition to water and sediment, Montana's streams and rivers transport large woody debris (LWD) from blowdown trees or channel migration into floodplain areas. LWD can have a major effect on stream form and function.

LWD accumulation is considered an important component of healthy aquatic systems. It provides stability to different channel types by capturing and retaining sediment. LWD accumulates on gravel bars or streambanks providing habitat for fish and other aquatic life by creating pools and providing overhead cover.

Over time, LWD degrades providing organic material for riparian plants and nutrients for aquatic organisms.

Loss of woody riparian vegetation and roads adjacent to streams further limits LWD sources and accumulation in streams, altering channel development and stability.

Removal of LWD by landowners, recreationists, or others can further degrade habitat and stream function.

LWD can also pose problems when it accumulates against bridges, structures, or against banks changing the flow of water to important infrastructure.



Stream channels evolved with native tree communities. Loss of large trees such as cedars from historical logging has resulted in changes in local and downstream channel stability.



Extensive blowdown from forest fires is an important mechanism for providing LWD, resulting in channel shifts and creation of new habitat.

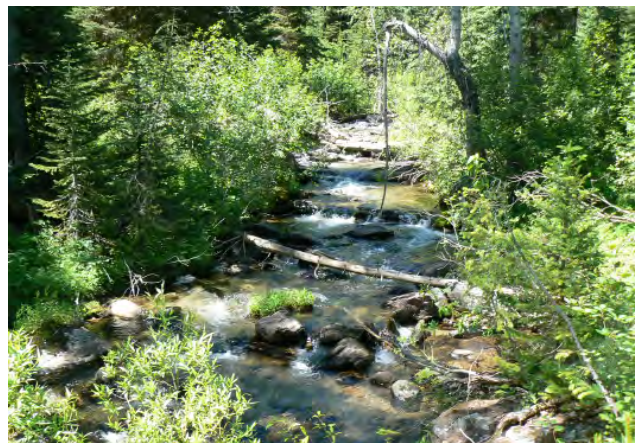

Trees fall across steep, narrow mountain streams and maintain grade control and step pool habitat.

ROLE OF BEAVER DAMS

Beavers were once abundant on Montana rivers and streams. Beaver dams helped shape the landscape and continue to play an important role in maintaining stream stability, groundwater storage, and riparian plant communities on many streams. Their effects, however, vary from stream to stream. Loss or removal of beaver dams can have significant and potentially undesirable channel changes that include downcutting, lowering of the water table, and loss of associated riparian vegetation.

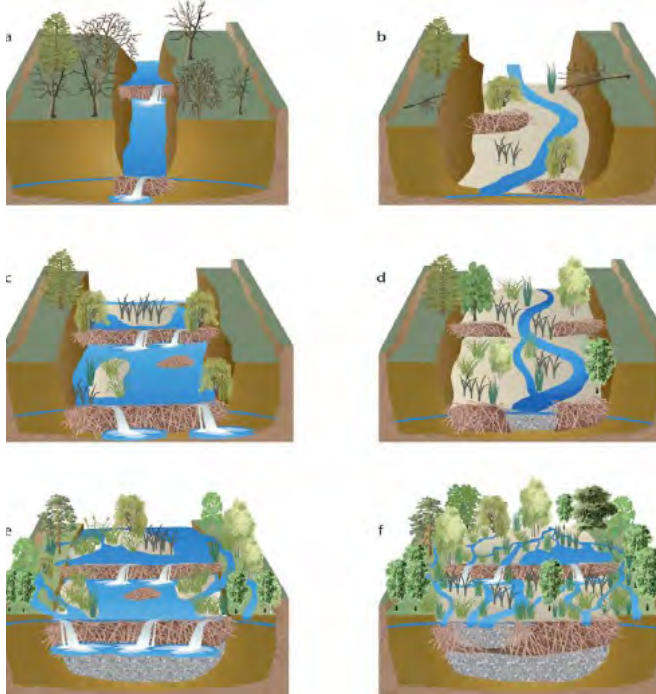

Sequence of incised channel recovery as a result of colonization by beavers.



Beaver Dam Effects on Incised Streams

- Beaver will dam streams within narrow incised channels during low flows, but stream power is often too high during runoff, which results in blowouts.
- During high flows dams blow, and an inset floodplain forms.
- The widened inset floodplain results in lower stream power, enabling beaver to build wider, more stable dams.
- Beaver ponds fill up with sediment and are temporarily abandoned. Accumulated sediment provides good establishment sites for riparian vegetation. This process repeats.
- Eventually, the beaver dams raise the water table sufficiently to reconnect the stream to its former floodplain.
- Over time, vegetation and sediment fill the ponds, and the stream ecosystem develops a high level of complexity as beaver dams, live vegetation, and dead wood slow the flow of water and raise groundwater levels. The result is a diverse system of multithread channels and wetlands that saturate the entire valley.

Note that this process can take decades to occur and is susceptible to changes in management.

*the beaver abounds on these Rivers - Sergeant John Ordway, August 8th, 1805
while travelling west with the Lewis and Clark expedition through the Missouri River headwaters*

CASE STUDY - BIG SPRING CREEK

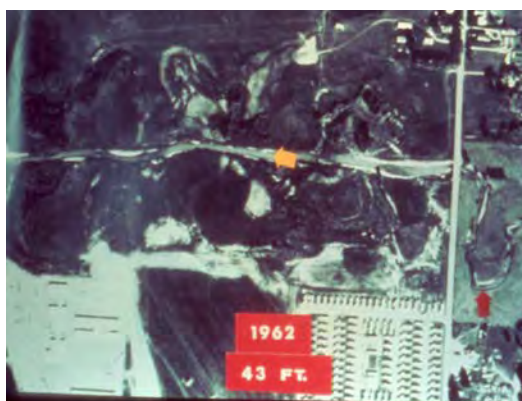
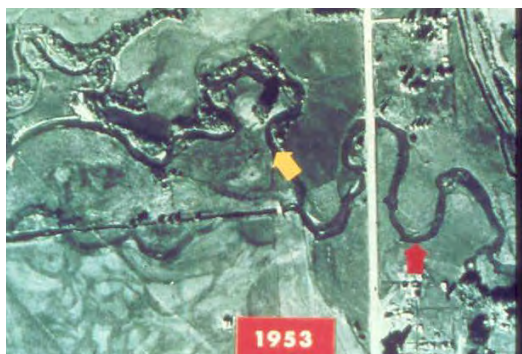

Aerial imagery sequence of Big Spring Creek. Photo to the right is from 2017 following channel reconstruction.

Big Spring Creek is a meandering, Rosgen C type, channel that runs through Lewistown. A portion of the stream, west of highway 191 was straightened to increase agricultural production. Channelization reduced the length of this reach from 6,000 feet in 1938 to 2,000 feet in 1962. The loss in length resulted in an increase in slope. An understanding of Lane’s Balance could have predicted the fate of this reach. Increased slope resulted in channel degradation. As the channel continued to degrade, high flows could no longer access the floodplain and the streambanks eroded. Prior to straightening the erosion rate was estimated at 0.2 feet/year; after straightening it was 13.5 feet/year. This resulted in an overwidened channel, loss of quality fish habitat, excess sedimentation, and increase in downstream flooding impacts.

The time series photos to the left show the historic straightened and resulting increase in channel width; 25 feet in 1938 and 133 feet in 1967.

A project completed in 2016 increased overall length by 60%, still short of the original length. The project recreated floodplain, used natural bank stabilization features and grade controls to improve overall functions. The project required extensive permitting and proved costly in time and money.

While the final result of the 2016 project improved the resource for fish and the community of Lewistown, it serves as a lesson in resource protection and promoting natural stream function. It is easier to maintain a stream and its functions than to have to restore them. The [lesson from Big Spring Creek](#) was one of many that led to the creation of the nation’s [first stream protection bill of its kind](#) in 1963, the Montana Stream Protection Act (124 Permit), followed in 1975 by Montana Natural Streambed and Preservation Act (310 Permit).



ADDRESSING STREAMBANK EROSION

This chapter addresses common project types and technical approaches for addressing streambank erosion through restoration and bank stabilization. These methods include bioengineering using native materials and revegetation as well as and more rigid structural measures. Before taking any of these actions, consider the underlying cause of erosion before you plan to address it. When looking at channel stability, an eroding stream bank is usually the symptom, not the process that should be considered. River systems respond to changes in the environment, including climate and land use. If imposed stresses (e.g., grazing pressure, channelization, etc.) can be managed or relieved, natural recovery is possible without a potentially costly intervention.

This chapter emphasizes a range of bioengineering/vegetative restoration methods, but also includes more rigid structural techniques for bank stabilization. Activities impacting the bed or bank will require permitting and should only be done in consultation with professionals. Landowners are encouraged to choose the methods that are least impactful to stream processes. These are often less expensive and require less permitting, while fitting within the local geomorphic, ecological, and social context of the landscape.

Contents

Project Planning & Design	3.2
Riparian Management	3.5
Revegetation Considerations	3.10
Fabric-Wrapped Banks	3.15
Vegetated Soil Lifts	3.17
Bankfull Bench/Terrace	3.18
Toe Protection	3.19
Root Wads / Woody Debris	3.26
Barbs / Vanes	3.28
Bendway Weirs	3.29
Rip-Rap	3.32
Channel Restoration Approaches	3.34
Avulsions	3.37
Aggradation	3.38
Flanking	3.39
Streambank Construction Sequence	3.40

Selected methods need to be balanced with risks, cost, and potential impacts inherent with each of these techniques. The expertise of a qualified professional can assist greatly in the selection of appropriate methods. Additional guidance can be found here:

- Cramer, M., K. Bates, D. E. Miller, K. Boyd, L. Fotherby, P. Skidmore, and T. Hoitsma. 2002. Integrated Streambank Protection Guidelines. Washington State Aquatic Habitat Guidelines Program, Olympia, WA.*
- NRCS (National Resources Conservation Service). 2007. Stream Restoration Design: National engineering handbook, part 654. U.S. Dept. Agriculture, NRCS, Washington, DC.*
- Saldi-Caromile, K., K. Bates, P. Skidmore, J. Barenti, D. Pineo. 2004. Stream Habitat Restoration Guidelines: Final Draft. Co-published by the Washington Departments of Fish and Wildlife and Ecology and the U.S. Fish and Wildlife Service. Olympia, Washington.*
- Wheaton J.M., S.N. Bennett, S. Shahverdian, J. Maestas. 2019. Low-Tech Process-Based Restoration of Riverscapes: Design Manual. Version 1.0. Utah State University Wheaton Ecogeomorphology & Topographic Analysis Lab. Logan, UT.*
- Yochum, Steven E. 2017. Guidance for Stream Restoration. U.S. Department of Agriculture, Forest Service, National Stream & Aquatic Ecology Center, Technical Note TN-102.3. Fort Collins, CO.*

PROJECT PLANNING & DESIGN

Project planning and design must consider stream function at different scales for the long-term success, of a project. The larger context of watershed processes and adjustments (Chapter 2) provides an understanding of how projects will function and their effects at the watershed level.

The scope of planning and design varies with the scale and extent of issues being addressed. It is important to consider the project objectives and whether the proposed solution will help meet those objectives while considering impacts to overall stream function. More complex issues will likely require consultation with a professional hydrologist or engineer and relevant permitting entities.

Within the watershed, reach-level processes include smaller scale channel functions such as local planform, profile, cross-sections, sediment transport, scour and fill, and land use influences. Reach level information provides context to design and implement projects that are consistent with natural river function.

Design Approaches

The most successful project designs include an understanding of stream morphology and processes combined with bioengineering techniques to promote natural river function. Numerous approaches to river restoration and project design exist. Designs include empirical, analytical hydraulics, analogue/reference reach, and hybrid methods such as the geomorphic natural channel design approach.

At the watershed and reach level, tools such as RiverRAT (River Restoration Analysis Tool) offer a process to develop projects with ecological and river function in mind. Although it is not a site-specific design methodology, RiverRAT provides a planning, assessment, and project review tool for projects. A detailed diagram of the RiverRAT process and design considerations are in Appendix 2.

CAUTION

- Look at the big picture and understand the problem before you plan to fix it (eroding stream banks are usually the symptom, not the underlying process or problem to be considered)
- Consult the local Conservation District and all relevant permitting entities early in the process to avoid time consuming and costly delays
- Consider alternatives that are appropriate to the landscape setting and will have the least impact on resources
- Consider the relative cost and likely long-term outcomes from selected alternative
- Consider adverse consequences that restricting lateral bank movement can have to channel function and re-establishment of long-term channel stability
- Consider whether a costly intervention results in a better long term outcome for the stream and/or the landowner

STREAM CHANNEL PROCESSES - SUMMARY

Factors in Channel Form and Process

Identifying the cause and solutions for bank instability can be relatively straightforward, or extremely difficult. Understanding basic concepts of stream form and function (Chapter 2) is necessary in evaluating a potential project. When in doubt, professional advice is recommended before beginning a project on unstable streams.

Basic factors to consider:

- Channel type (Appendix 1)
- Condition of riparian vegetation
- Adjacent land management or objects
- Aggrading or degrading conditions
- Lateral movement (size of depositional bar and vegetation gives good indication of rate of movement)
- Relative condition of upstream and downstream reaches

REMEMBER LANE'S BALANCE

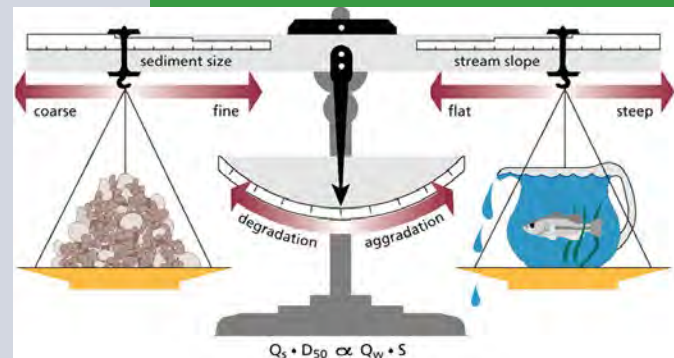

Consider Channel Process before Channel Project

Understanding the underlying causes of bank instability is essential to selecting an effective bank treatment. In addition to examining upstream and downstream conditions, channel classification, aerial photos, and historical accounts can be helpful for interpreting channel process. An eroding bank is often the symptom of larger channel instability in the stream system. Stabilizing an eroding bank with natural or engineered materials often does not address the underlying cause of bank erosion. Extensive bank stabilization in channels undergoing certain types of change can degrade channel stability by constraining the channel from making needed adjustments. It may also result in a higher risk of failure.

Relevant questions to ask (and answer):

- Is instability systemic or localized?
- Is bank instability only lateral (side to side), or is the stream adjusting vertically?
- Is instability accelerated or natural?
- Does adjoining land use or disturbance play a role?

Examples of factors common with localized erosion are:

- Weak banks due to lack of vegetation or conversion from shrub to grass
- Scour associated with channel obstructions (ice, structures, slumping, or bridge abutments)

- Extreme events (icing, peak flows, tree blowdown)
- Channel aggradation upstream of undersized structures (e.g., culverts)

Example causes of large scale, systemic-type erosion include:

- Channel straightening
- Highway and railroad encroachment
- Extensive diking
- Inherent, large-scale watershed processes
- Extensive removal of vegetation in the watershed
- Mining

PASSIVE RESTORATION - THE NO ACTION ALTERNATIVE

Factors to consider before taking action

- Streambanks naturally erode and move across their floodplain (Chapter 2)
- Long-term goals for managing the land
- Consequences of not taking any action
- Cost of stabilization or restoration against the value of the land that may be lost to erosion
- Value of healthy stream and riparian systems
- Likelihood of success/failure of other alternatives

Accelerated erosion can create instream issues and affect economic bottom line of landowners. However, some erosion is necessary for ecological stream function. Therefore, landowners should consider providing adequate space for streams to erode and move across their floodplain.

Streams and riparian areas are resilient to some level of disturbance. Once the disturbance has been eliminated, vegetation will begin to recover over the course of a few years providing long term bank stabilization. This may take longer and result in some continued bank erosion and loss of land.

In order to restore passively to pre-disturbance conditions, a stream **must** have access to its floodplain at regularly recurring intervals and seed or root sources for revegetation.



Excluding surrounding land use and providing a buffer for this stream to move will reduce impacts to the stream and landuse operations.



Promoting natural recovery of native wetland and woody riparian plants is much less expensive than planting the equivalent nursery stock.

Landowner Considerations

- Distinguishing between change that falls within the range of natural variability and adverse impacts from land use is important in deciding if and how to intervene or compensate for channel response
- Rivers take care of themselves, and most channels don't need "fixing"
- Land use should be considered carefully
- If people are part of the problem, should they be part of the solution?
- Seek advice from Conservation Districts, agency staff, or qualified professionals.

RIPARIAN MANAGEMENT

Historical and ongoing land management are major sources of streambank instability and erosion throughout Montana. Deep rooted woody vegetation that lined stream corridors was removed to provide increased forage for domestic livestock and acreage for crop production. Over-utilization of riparian areas for grazing increases bank trampling and prevents vegetation from regenerating.

Producers are recognizing the value of riparian areas for their operations. Maintaining a riparian buffer on cropped fields reduces land lost to streambank erosion. Careful management of livestock with fencing or modified grazing schemes can improve and maintain the health of riparian areas and benefits they provide.

Considerations for grazing in riparian areas:

- Incorporate into overall grazing management
- Limit duration of livestock in riparian area
- Ensure adequate rest and vegetation regrowth
- Consider season and frequency of use

For more information on grazing methods and available resources, contact your local NRCS office.



One side of stream has not been grazed for 40 years and maintains deep-rooted woody vegetation.



Tilling up to the streambank reduces stability. Erosion is accelerated, particularly on an outside meander bend. Consider the value of arable land against long-term consequences and solutions. A 50 foot buffer along 1,000 feet of stream is 1.15 acres.

BENEFITS

- Low cost and low risk - mitigates against future needs to restore or stabilize streambanks
- Improved streambank stability and water quality
- Grants and cost share available from state and federal agencies to initiate riparian BMPs
- Fencing typically costs between \$1 to \$5 per lineal foot
- Riparian pastures can provide access to quality forage during times less likely to impact stream function
- Willow stands provide refuge for spring calves

CAUTION

- Ensure fencing provides enough room to allow natural channel migration
- Restoring natural conditions takes time
- Recovery of riparian vegetation may take years
- Restabilization of streambanks and restored channel function may take decades

GRAZING MANAGEMENT - WATER GAPS and HARDENED CROSSINGS

Reducing livestock access to riparian areas has challenges, including ensuring access to drinking water and the land across the stream. This is best accomplished through off-stream watering tanks, water gaps, and hardened stream crossings that minimize disturbance to the streambank and channel.

Considerations for water gaps and hardened stream crossings:

- Locate in areas where the streambed is stable
- Crossings should be no less than 6 ft and no more than 30 ft wide
- Blend approaches to the stream crossing with existing site topography
- Locate just upstream or downstream of natural barrier when possible
- Exclude livestock access to the crossing using fence and gates
- Install cross-stream fencing at fords that allows the passage of floodwater and large woody material during high flows
- Use streambank bioengineering practices to stabilize adjacent banks as necessary
- Revegetate disturbed areas after construction
- Avoid known spawning areas of sensitive species



Riparian fencing will allow woody vegetation to re-establish and a water gap provides controlled access to water for livestock. Larger riparian enclosures can compliment rotational grazing and provide additional room for streams to migrate.



A hardened crossing provides a discrete area for livestock to access the stream and additional pastures. The swinging flood gate placed across the water with drop PVC pipes allows for high flows and debris to pass.

CAUTION

- Geotextile may not be required at well armored sites
- Biodegradable geotextile should be used if necessary
- Do not create a passage barrier where aquatic species are present and using the stream

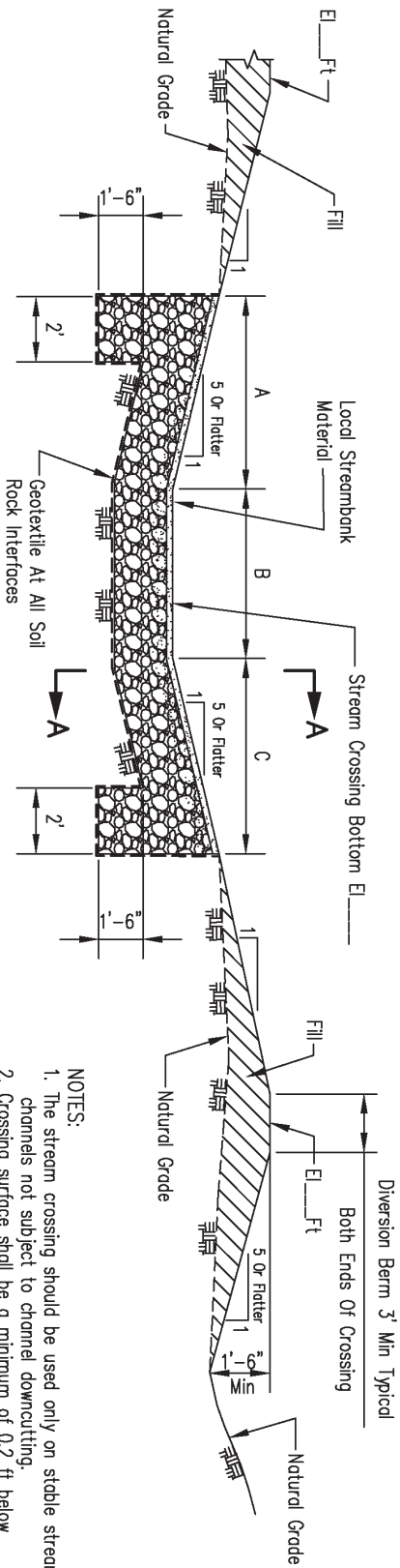

PROFILE ALONG CENTERLINE OF CROSSING

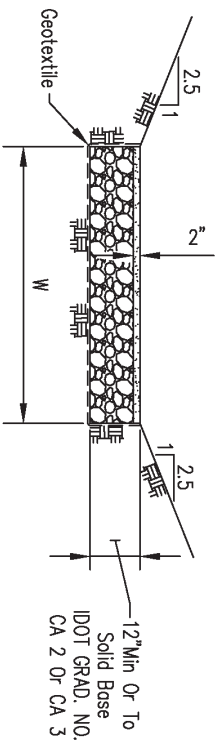

SECTION A-A

DIMENSIONS
 A = _____ (Ft)
 B = _____ (Ft)
 C = _____ (Ft)
 W = _____ (Ft)
 Station _____

- NOTES:
1. The stream crossing should be used only on stable stream channels not subject to channel downcutting.
 2. Crossing surface shall be a minimum of 0.2 ft below channel invert.
 3. Surfacing material shall be compacted so that the entire surface is traversed by not less than one tread track of the load hauling equipment.
 4. Berms at each end of the crossing shall be constructed to direct surface flow away from excavated crossing, as directed by the engineer.
 5. All disturbed areas not covered by gravel shall be seeded in accordance with Critical Area Planting Standard (Practice Code 342).
 6. Excavated material shall be removed from site, used for diversion berms or placed at least 12 feet from top edge of back slope and spread so that the height does not exceed 1 foot. The spoil material shall drain freely.
 7. Geotextile (non-woven) minimum criteria:
 Weight of Geotextile (oz./sq.yd.) _____ 6
 Tensile strength (lb) ASTM D 4632 _____ 180
 Elongation at failure (%) ASTM D 4632 _____ \geq .50
 Puncture (lb) ASTM D 4835 _____ 80
 Ultraviolet light ASTM D 4355 _____ 70
 Apparent opening size (AOS) ASTM D 4751 _____ max 40 sieve
 Permittivity sec $^{-1}$ ASTM D 4491 _____ 0.70
 8. Any geotextile splices shall overlap a minimum of 18 inches, with upstream or upslope geotextile overlapping the abutting downslope geotextile.

ESTIMATED QUANTITIES	
Excavation	Cu. Yd.
Coarse Aggregate	Tons.
Geotextile	Sq. Yd.
Seeding	Acres

Landowner _____ Location _____

Date	
Designed _____	5/09
Drawn M. QUINONES	
Checked _____	
Approved _____	

STREAM CROSSING FOR LIVESTOCK



File No. IL-ENG-179
 Drawing No.

Sheet 1 of 1

LIVE CUTTINGS

Live woody cuttings, often willow, are tamped into the soil to root, grow, and create a dense root mat that stabilizes the bank.

Applications

- Re-vegetate stream banks, slopes, floodplain
- Repair small earth slips and slumps that are frequently wet
- Effective where site conditions are uncomplicated
- Construction time is limited
- Inexpensive method if material is available

Design and Construction Techniques

- Can be used to stake down geotextile erosion control fabric or stabilize areas between other soil bioengineering techniques
- Where appropriate, should be used with other soil bioengineering and vegetative plantings
- Enhances conditions for establishment of vegetation from the surrounding plant community
- Stakes are 2 to 4 feet long, 0.5 to 1.5 inch in diameter, and are inserted with basal end to water table or saturated soil (~75% of stems covered in soil)
- Using rebar or dibble speeds installation with a starter hole
- Most successful if planted while dormant - in fall after leaves fall off to spring prior to leaves budding
- Most native willow species are suitable; using more than one species of locally sourced willows is most successful
- Beaver, rodents, and livestock can reduce survival of new plantings
- Locations within the floodplain, or where erosive forces are low, can be sprigged with cuttings alone



Live willow cuttings seem to survive best when cut and planted in the early spring prior to bud break.



Willow cuttings work well planted through geotextile fabric if the basal end of the cutting can reach the water table. Irrigation is also useful to help establish new cuttings.

CAUTION

- Requires toe protection where excessive toe scour is anticipated
- Most successful if used in conjunction with geotextile (organic fabric) or rock treatments within the high water mark
- Must be in contact with the groundwater for substantial portions of the year to establish cuttings
- May require protection from animals during establishment

DORMANT POLE PLANTINGS

Plantings of cottonwood, willow, dogwood, or other species are driven into streambanks to increase channel roughness, reduce flow velocities near the slope face, increase shade, and trap sediment.

Applications

- Most types of streambeds where poles can be inserted to reach water table
- Stabilize rotational failures on streambanks where minor bank sloughing is occurring
- Establishing riparian trees in arid regions where water tables are deep
- Will reduce near-bank stream velocities and cause sediment deposition in treated areas
- Joint plantings in pre-existing rip-rap
- Generally self-maintaining and will re-stem if damaged by beaver or livestock, but limiting livestock access will speed recovery
- Best suited to non-gravelly streams and where ice damage potential is low
- Poles are less likely to be removed by erosion than are live stakes or smaller cuttings
- Can be used with geotextiles and vegetative plantings to stabilize the upper bank



Dormant willow poles have the best survival when they do not compete with mature sod.



An excavator with a dibble is used to place plantings.

Design and Construction Techniques

- Pole plantings are often used in conjunction with rock or geotextile treatments.
- Robust species such as yellow willow or cottonwood are preferred.
- Plantings will generally require a dibble for effective installation of poles below water table.
- Use 1 inch to 5 inch diameter, dormant material collected in early spring.

CAUTION

- Unlike smaller cuttings, pole harvesting can be very destructive to the donor stand.
- Poles should be gathered as “salvage” from sites designated for clearing, or thinned from dense stands.
- Equipment access should be carefully planned to avoid damaging banks.

REVEGETATION CONSIDERATIONS

Revegetation efforts are a key component for most restoration and stabilization projects. Establishing woody shrubs and trees will promote long-term bank stability on softer bioengineering projects and can provide some ecosystem benefit to harder approaches such as rip-rap. Willow is often used because it can root and establish quickly providing bank stability even in areas where different plant composition is expected over time.

Willow Cuttings

Know Your Willows

Willows have the highest survival rate when harvested locally. Nearby plants are already adapted to local climate and soil conditions. Species such as: sandbar or coyote willow (*Salix exigua*), booth willow (*Salix boothii*), yellow willow (*Salix eriocephala*, *S. lutea*), and geyer willow (*Salix geyeriana*) have the highest survival rates. Drummond and Booth willow can be used successfully. Bebb's can be more difficult to establish.

Harvest Dormant Plants

Dormant willows divert energy from leaf production to root production. Establishment of plants requires growing roots, not leaves. For this reason, they are more likely to successfully root from a cutting without leaves. The dormant season extends from leaf drop in the late fall/early winter to bud break in the early spring.

Size Matters

The optimal size of cuttings depends on the application. No matter where you plant cuttings, you want your willows to have their “toes” in the water and their “heads” in the clouds. In general, willow stakes should be about four to five feet tall and willow layers should be at least six feet long. Ideally, cuttings are thumb-sized or bigger (somewhere between $\frac{3}{4}$ and $1\frac{1}{2}$ inches in diameter). Small whips are unlikely to root, except under ideal conditions.

Choose Wisely

Most projects easily incorporate thousands of live willow cuttings. Healthy plants that are two to seven years old (look for smooth, not rough, bark) are ideal. Cuttings should be straight with the side branches and top several inches removed. Trimming back the ends of the cuttings reduces excessive leaf growth and encourages initial root production. To establish cuttings in the first years, the plant's stored energy needs to be invested in developing roots, not leaves.



Locally harvested plant material is preferred, as it is best adapted for local conditions.



Clean plant material greater than 0.5 inches in diameter is preferred.



Willow stakes can be planted through fabric or into soils or sod.

*REVEGETATION CONSIDERATIONS (continued)**Moisture is Key to Establishment*

Ideally at least 6 inches of the willow stem cutting is in the mid-summer water table and approximately two-thirds of the cutting is planted into the ground with approximately one-third of the stem remaining above ground.

If long periods of inundation exceeding 30 days are likely, cuttings should be long enough to extend 6 to 12 inches above the expected high water level. Temporary irrigation can help establish new cuttings.

Sunlight Counts

Willows do best in sunny locations. Establishing willows in heavily shaded areas has reduced success. If weeds or aggressive plant species are present, the willow stem cutting should be long enough to extend both above the herbaceous summer growth (to receive adequate sunlight) and below the weed root mass (to minimize competition for space and nutrients). If tall grasses such as smooth brome or timothy are present, willow cuttings should extend above the leaves of the tall grass species.

Don't Forget to Bundle and Soak

Once cuttings are harvested and pruned, bundle them into groups of 10 to 20 with twine. Ideally, cuttings should be soaked in water at least 48 hours and up to 2 weeks prior to installation. Soaking willows keeps the cuttings from drying out after being planted and encourages early root growth. Cuttings that are stored for extended periods or left in the sun have low success. Rooting hormones such as Indolebutyric acid (IBA) and naphthaleneacetic acid (NAA) and others can be used in powdered or solutions to enhance rooting in difficult sites.

Browse Protection, Cuttings, Plugs and Bareroots

An alternative to rigid fencing or browse protectors is the use of repellents such as Plantskydd or Ropel (trade names for two products) that are used to discourage browse from elk, moose, deer and beaver. Plantskydd lasts up to 6 months (including over the winter). Repellents applied twice a year for a couple of years following willow installation may prove to be a better alternative to fencing.



Base of willow cuttings should touch groundwater where possible.



Soaking willows prior to planting is important to establishment. After two weeks of soaking fragile roots will emerge and may be damaged during planting.



Cuttings should be trimmed so approximately one-third of the stem is exposed.

Dormant cuttings can be stored in a cooler or snow stash 1-1.5 months before use.

MANAGING BEAVERS

Beavers helped shape the existing landscape and play key roles in maintaining proper channel form and function. However, beavers also have the potential for damaging property by removing trees and causing localized flooding. Landowners find that the consequences of removing beavers and their dams are often worse than learning to manage the beavers and their activities.

Beaver dams are sometimes removed to:

- Reduce flooding
- Eliminate obstructions at culverts, headgates, or bridges
- Prevent new channels from forming around dam.
- Drain wetland areas
- Eliminate beaver damage to mature streambank trees
- Provide access for migratory fish spawning areas

Culvert protection

Beaver will attempt to plug a culvert because the sound and speed of water rushing through resembles that of a hole in their dam. There are different devices such as a “Beaver Deceiver” that block off the culvert entrance and divert the sound and feel of water moving into the culvert.



Beaver deceiver™ installed at upstream end of culvert to prevent beaver from damming.

Beaver dam removal more often results in:

- Channel downcutting
- Excess bank erosion
- Lowering water table
- Sediment release to downstream reaches
- Streambank instability
- Damage to riparian vegetation and fisheries
- Beavers eventually rebuilding dams

Tree protection

There are several methods for protecting trees from beavers. Fencing large clumps of trees or individual trees is common. A paint mixed with sand can also prove effective by applying to the bottom 3-4 feet of the trunk.



Sand mixed with paint to match the bark of the tree can be a discrete way to prevent beaver damage. Photo courtesy of Sierra Wildlife Coalition.

BEAVER MIMICRY

Beavers as a stream restoration tool

- Reintroduction of beavers may be a viable way to elevate the water table, aggrade incised streams, and enhance riparian vegetation where existing conditions are suitable
- Structures that mimic beaver dams, beaver dam analogs (BDA) can be used to restore incised streams; however, long-term viability requires continued maintenance or eventual re-colonization of beavers
- Beaver populations can expand rapidly in uninhabited areas with suitable habitat

BDA Design and Construction Techniques

- Install one to three rows of untreated posts or small logs spanning the width of the channel
- Space posts 12-18 inches apart and drive at least 18 inches below the channel bed
- Weave brush (e.g., green conifer) and live willow between posts, packed down tightly while still ensuring water will pass through
- Pack gravel and mud on upstream side near base
- New brush and willow should be added as old ones degrade to continue to slow flows and collect sediment
- Revegetate surrounding floodplain to enhance suitable beaver forage and habitat

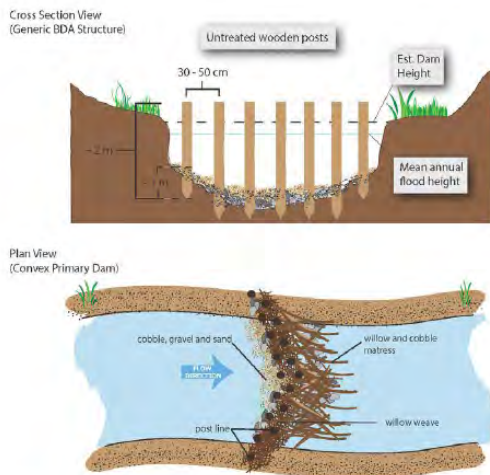

Conceptual illustration of BDA using wooden posts by Elijah Portugal.



Recently installed BDAs slowing runoff and aggrading an incised channel

CAUTION

- BDAs are not appropriate in all streams or situations; structures may impede fish movement or locally degrade stream habitat by creating impoundments
- Consultation with an FWP fisheries biologist early in the planning process is recommended before installing beaver mimicry structures; they can identify potential fish passage issues and necessary permits
- Beaver dams should not be removed unless flooding upstream will cause significant damage
- Before removing beaver dams, weigh the benefit against potentially undesirable channel changes
- Legally trapping beaver requires a license or damage permit from FWP
- Given suitable habitat new beavers often relocate to the trapped area within 1-2 years
- Without adequate woody vegetation for forage and building beavers will abandon a site

SOFT BIOENGINEERING

River Stabilization or Restoration?

Set Clear Objectives

When selecting bank treatments consider the level of protection needed, and whether the project is intended to be “restoration” or “stabilization.”

Restored Banks

For restoration, banks are designed to replicate natural channel stability, and allow some bank movement over time comparable to natural rates. These projects will generally employ biodegradable fabrics and rely on vegetation established for long-term protection.

Stabilized Banks

Stabilized banks are designed to withstand erosion irrespective of natural channel migration rates. These projects generally employ permanent fabrics or hard structural techniques such as rip-rap. Because hard armoring limits natural channel processes, they should be employed sparingly and carefully to avoid adverse impacts to channel stability.



Restoration of streambanks using bioengineering techniques can provide excellent bank stability and promote natural channel function.



Restored streambank using coir fabric, willow plantings and sod (same location as above photo).

Soft Bioengineering Methods

Soft bioengineering methods may be preferred where:

- Adequate vegetation can be established within several years
- Restoration has precedence over immobilizing bank
- Costs are competitive with hard engineering due to material costs (usually the case)
- Volunteers can be recruited to reduce costs
- Risk associated with natural methods is acceptable
- Hard methods are unacceptable due to potential channel impacts



Biodegradable geotextiles can last 2 to 4 years while vegetation becomes established. Note, however, that the fabric in this photo has been abraded in the first year. Ultimately, all biodegradable fabric treatments rely on vegetation for long-term stability.

FABRIC-WRAPPED BANKS

Fabric-wrapped banks are an excellent alternative to rip-rap for stabilization of eroding banks with natural vegetation.

Applications

- Restoring eroding banks with low to moderate erosive forces
- Alternative to rip-rap and other hard treatments
- In conjunction with woody debris, brush layering, or tree revetment techniques

Design and Construction Techniques

- Banks are sloped at 2:1 or less when possible; steeper 1.5:1 slopes can be vegetated, but are more vulnerable to failure
- The toe is stabilized as required (often with rock, large cobble, or woody debris)
- Geotextile fabric is wrapped over smooth slope with topsoil plus seed, or salvaged sod
- Raw fill materials may limit seed or cutting establishment. Top soil is important
- Staples, wood stakes, rebar, and willow cuttings are used to help hold fabric in place
- Cuttings or plantings can be incorporated into fabric banks, either through fabric, or in lifts

CAUTION

- Biodegradable fabrics eventually break down and bank stability relies on mature vegetation for long-term stability
- Unless stabilized, the toe of the bank can scour and undermine fabric
- A mature geotextile bank can be nearly as inflexible as rip-rap, and can impair channel dynamics
- Rock toes act as rip-rap and should be used only when absolutely necessary
- Fabric may be vulnerable to damage from ice and drifting woody debris before vegetation matures



High terrace banks are common in eastern Montana and are well suited to simple geotextile treatments.



Stream banks are sloped to a 1.5:1 or 2:1 angle and covered with biodegradable geotextile fabric. Toe protection is frequently brush or willow layers. Same location as above photo.



This site used rock to stabilize the toe, however, brush or woody debris would have been equally effective and preferred.

GEOTEXTILE EROSION CONTROL FABRICS

Geotextile Fabrics

Erosion control fabrics are made out of many different fibers. Some are completely biodegradable, and others include a plastic mesh matrix. Heavier weight fabrics are sometimes referred to as Turf Reinforcement Mats (TRMs).

Natural Fabrics

- Coconut blankets
- Jute mesh
- Coir fabrics (700g and 900g)
- Straw

Natural materials provide short-term erosion protection, but break down over several years (typically 2 to 4 yrs). Vegetation must provide long-term erosion resistance.

Synthetic Fabrics

Synthetic fabrics are permanent and break down slowly if exposed to sunlight (over decades). They are not recommended (and in some cases prohibited) for use below the ordinary high water mark because plastic can cause entanglement of birds, snakes, and aquatic life in the mesh.



Natural fiber erosion fabrics are commonly made with coconut or jute.



Finer coconut fabrics are frequently layered beneath the coarse coir fabric to prevent loss of fine soils.

Soft Bioengineering can be strong.

Fully revegetated fabrics can provide the equivalent protection of 2-foot rip-rap with good vegetation.

Coconut or jute blankets typically last 2 to 4 years depending on conditions, after which vegetation is most important for maintaining stability.

Fabrics are commonly used in double layers with a fine coconut fabric wrapped beneath a heavy coir mesh.

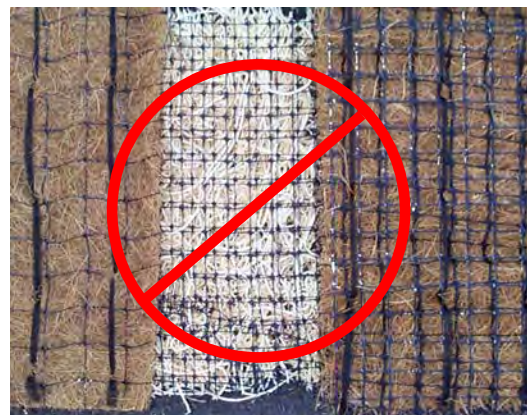

Hybrid natural and synthetic fabrics should be avoided whenever possible because the plastics can become a nuisance.

VEGETATED SOIL LIFTS

Vegetated soil lifts employ geotextile fabrics, sod, woody cuttings and plantings to achieve a naturally stabilized bank. Depending on design criteria and erosive forces of the site, vegetative soil lifts employ a range of techniques. Vegetated banks can be designed to replicate natural streambank stability and become self-sustaining as vegetation becomes established. Banks may also be designed for shorter term, temporary bank protection, or be hardened using woody debris to provide more robust protection. In particular, expected scour at the toe of the bank and countermeasures to compensate for erosive forces are primary considerations for vegetated soil lifts.

Applications

- Streambanks with light to moderate lateral erosion and good vertical stability
- Small patches of bank that have been scoured out or have slumped leaving a void (appropriate after stresses causing the slump have been removed)
- Eroded slopes or terraces where excavation is feasible to install branches/woody debris toe



Encapsulated soil lifts with LWD toe and willow cuttings.



Geotextile bank treatments can be labor-intensive. Backfilled brush layer in place, ready for first soil lift.

Design and Construction Techniques

- Brush layers may be incorporated into many types of slope and bank reconstruction
- Use live willows, cottonwood, or other plant material, preferably a species that will root
- Shape the streambank to grade less than 1.5:1. Lay plant material on the successive “lifts” of a fill or in trenches cut successively from the bottom to the top. Soil removed from each successively higher cut is used for fill over the brush below
- The cut material will vary in length depending on slope dimensions. Brush may be up to 6 feet or longer
- Cut branches should be laid in a crisscross pattern for greater stability
- Use dormant plant material cuttings (late winter, early spring or fall)
- Details on construction of soil lifts are found in the following pages

CAUTION

- Vegetated soil lifts are typically not effective in large slump areas.
- Droughty soils may limit establishment of cuttings.
- Toe protection is required where toe scour is anticipated.

BANKFULL BENCH/TERRACE

High eroding terraces are challenging to stabilize due to the steep, sometimes near vertical slope and position of the river against the toe. Construction of a bankfull bench at the toe of the slope can provide a means to stabilize the site without sloping back the high terrace. Cutting back the terrace can be difficult due to site constraints and large volumes of fill to be moved. Revegetation of steep slopes presents additional challenges.

Construction of a bankfull bench normally requires encroaching on the active channel. In impaired, overwidened (high width/depth) channels, this encroachment may fall within the range of naturally functioning channel geometry. In other cases, reshaping of the channel will be required to compensate for the fill and preserve conveyance. Toe protection will also be required on outside meander or high energy systems.

In FEMA mapped floodplains, hydraulic analyses will normally be required to evaluate the potential effects the encroachment in the floodway (i.e., “no-rise” analysis). A common approach is to re-shape the channel cross section to offset the bankfull bench fill with an equivalent amount of gravel excavation on the opposite bank.

Construction materials should be appropriate to the stream’s landscape setting and hydrology. The large wood and materials in the diagram may not be necessary in many streams, where cobbles, willows, and sod mats would be more contextually appropriate.



Before - An eroding bank (e.g., terrace or hillside) can sometimes be stabilized by construction of a bankfull bench. This may require channel reshaping to offset fill placed during construction of the bench.



After - Bankfull benches are most often successful where channel reshaping can take erosive pressure off the bank, or in locations without strong lateral movement and scour.

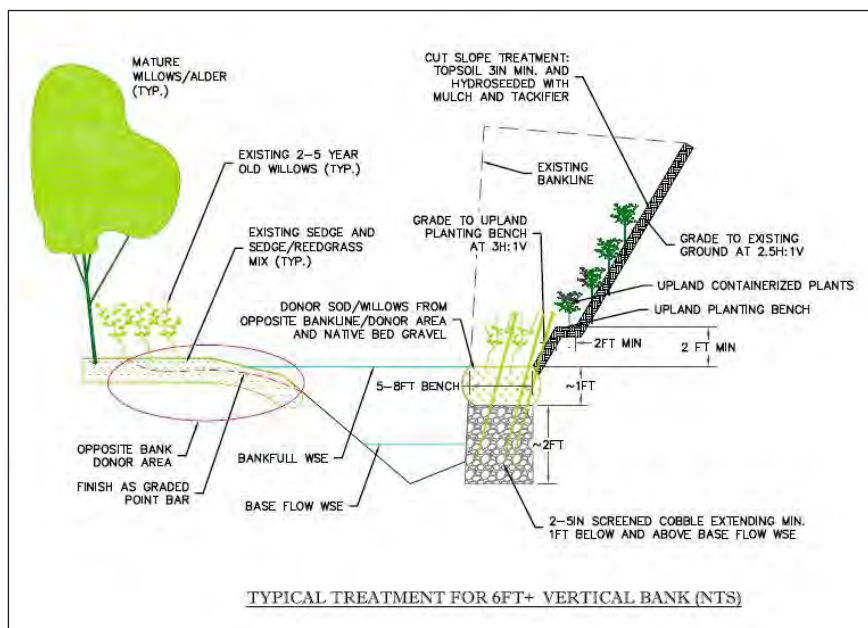

Design drawing provided by Gillilan Associates, Inc.

TOE PROTECTION

Like the foundation of a house, the toe of a bioengineered bank maintains the structural integrity of the bank during peak flows and scour. An appropriately designed toe is critical to the success of bioengineered bank treatments. Properly designed means: constructed to withstand expected scour depths, erosive force, buoyancy, and icing for the design life of the project.

Scour depths increase with the tightness of the meander, and channel substrate (bed material) varies in its inherent ability to withstand scour. Bank stabilization efforts in meandering gravel bed C channels are particularly vulnerable to undermining and failure by toe scour. In finer grained bed material and banks, slumping associated with saturated soils may also be an important factor.

The design life and deformability criteria of the treatment both factor into the type of toe construction. Not all foundations/toe treatments necessarily need or should be designed to last 100 years, or withstand a 100 yr flood. Softer treatments (e.g., using brush in lieu of large woody debris) are often warranted where maintaining a natural channel function and deformable banks is desirable.

Design Considerations:

- The toe of bioengineered banks should consider expected scour depth, deformable vs. rigid protection, design life, and channel process.
- The deepest pool in the adjacent stream reaches can be a good indicator of potential scour depth.
- From a long term ecological and channel function standpoint, woody material is generally preferred to large rock.
- Channel reshaping in conjunction with bank treatments can be an important component to achieving desired bank stability.
- Rivers with deep scour may be difficult to treat with large woody debris, as placing wood deep below the low water level creates challenges for installation (i.e., buoyancy).



In low erosion/scour locations, toe protection may be “soft” techniques such as coir logs or biodegradable fabric lifts.



In moderate scour or erosion applications, toe protection can include brush layers, fascines, and small woody debris.



A robust toe protection technique relies on large woody debris to provide a high degree of scour protection.

BRUSH FASCINES

Fascines (or wattles) are live/dormant or dead branch cuttings bound together into long, cylindrical bundles. They can be used as toe protection and in combination with reconstructed streambanks (e.g., soil lift) under moderate shear stress conditions.

Fascines provide roughness and habitat complexity to the channel margins and short-term stability that provides time for vegetation to mature and provide long-term stream bank stability.

Fascines made from dense conifer branches or whole trees (e.g., Christmas trees) help trap sediment and provide a good medium to allow rooting of live cuttings incorporated into the fascines.

Fascines can also be used to reinforce gentle slopes above the high-water mark by trapping sediment and retaining moisture for revegetation.



Conifer fascine provides added hydraulic roughness and habitat complexity compared to coir logs or rip-rap



A conifer fascine toe with three soil lifts provide contextually appropriate treatment to stabilize this bank on the Madison River.

Design and Construction Techniques

- Prepare fascines using conifer slash, Christmas trees, or live shrubby material (e.g., willow)
- Tightly bind material together into a cylinder using heavy, biodegradable twine
- Ensure individual limbs overlap by at least 1.5 feet and stacked in alternating directions
- Individual fascines should be at least 7 feet long and up to 20 feet
- Diameter is based on shear stress and bank configuration but should be at least 1 foot
- Fascines are set in place, bound together, and anchored with wooden stakes at the toe of the new bank
- Dormant willows cuttings should be staked into the bank through the fascine or incorporated into a soil lift on top of the fascine

CAUTION

- Vulnerable to erosion under high shear stress
- A good anchoring system is necessary
- Not effective to control large mass movement on slopes

BRUSH AND WOOD MATRIX

A mixture of alluvium and brush or small diameter wood can provide temporary bank stability to a restored bank. The size and quantity of woody material used is dictated by the shear stress and erosive forces on the treated bank. In high energy streams, the matrix can be constructed on a larger rock toe.

Brush is placed perpendicular to the bank, extending into the channel at different angles to provide roughness and fish habitat along the channel margins. Sod mats and other revegetation is important to provide long-term stability as the wood and brush decay. Live cuttings should also be incorporated into the matrix and staked into the top of the bank.

Similar to a brush fascine, a brush and wood matrix can also be used to stabilize the toe of a reconstructed streambank in conjunction with other bioengineered applications like a soil lift. Instead of being bundled and placed horizontal to the stream, brush and wood are stacked perpendicular to the bank.



A brush matrix provides short-term stability and roughness. Native sods mats, willow cuttings, and nurse stock are planted to ensure long-term stability.



Ratio of brush and alluvium is dictated by local erosive forces.

Design and Construction Techniques

- Excavate trench at least 5 feet from edge of streambank sloping back to below streambed
- Stack and compact brush, small diameter wood, dormant willow cuttings, and mixture of native alluvium in alternating layers
- Dormant willow cuttings should be placed at the back of the trench below streambed level with at least a third of length extending above bank surface
- Bank should be constructed to approximately bankfull height

CAUTION

- Bank deformability is expected; should only be used where bank movement is tolerable
- Ensure that wood and brush are appropriately sized to the local flows and conditions
- Requires additional toe protection where excessive toe scour is anticipated
- Upstream and downstream ends of structure are most at risk of flanking and erosion

VEGETATED SOIL LIFT (Type 1) with Coir Rolls

Purpose: Revegetation, bank stabilization, channel margin roughness.

Location: Within the passive margin along riffle, run and glide features.

Stability Criteria: Built on cobble toe material, outer fabric is high strength coir, structure is anchored to bank with wooden wedge stakes.

Habitat attributes: Cover and shade

Supplemental Info: The vegetated soil lift with coir roll is a bioengineering technique that employs coir fabrics to provide conditions along the channel banks that are suitable for growing woody riparian vegetation. The method provides bank protection when used in conjunction with a sequence of other channel bed and bank structures. Typically the structure is placed along the outer bank of high-radius meander bends exhibiting poor soil conditions and a lack of vegetation. Structure performance is dependent upon vegetation growth and placement of cutting at elevations in contact with the baseflow water table during the growing seasons. The design life of the structure is temporary and intended to provide short term stability until woody vegetation becomes established. Over a period of several years, the coir products will decompose and the rooting strength of established vegetation is intended to maintain low bank erosion rates.

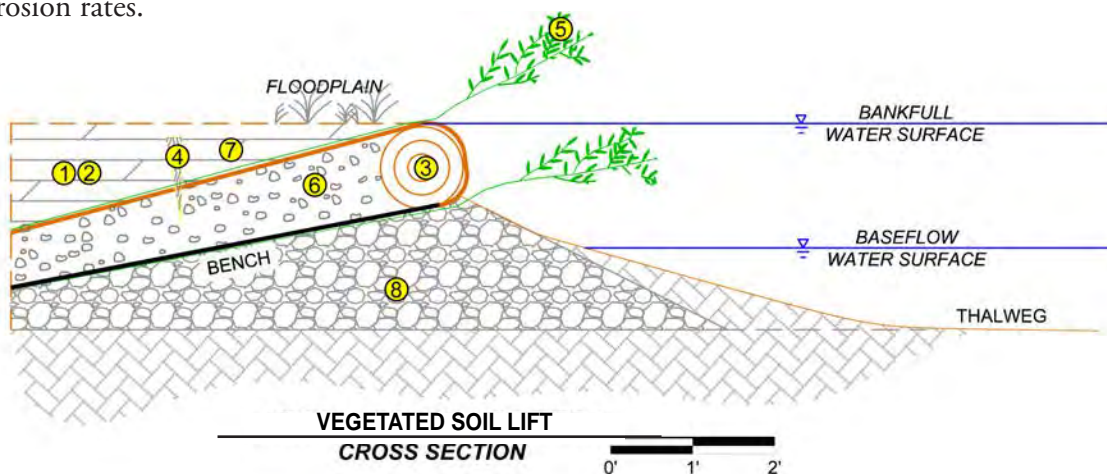

LEGEND	
① COIR MAT	⑤ WILLOW CUTTINGS
② COIR FABRIC	⑥ GRAVEL/SOIL MIX
③ COIR LOG	⑦ GROWTH MEDIA
④ WOODEN WEDGE STAKES	⑧ ALLUVIUM



Example of a constructed vegetated soil lift type 1



Example of a constructed vegetated soil lift type 1

VEGETATED SOIL LIFT (Type 2) Multiple Layers

Purpose: Revegetation, bank stabilization, channel margin roughness.

Location: Within the active margin along the outer bank of meander bends.

Stability Criteria: Built on cobble toe material with wood intermixed, outer fabric is high strength coir, structure is anchored to bank with wooden wedge stakes.

Habitat Attributes: Cover, shade, hydraulic complexity.

Supplemental info: The vegetated soil lift is a bioengineered technique that employs coir fabrics and wood to provide conditions along the channel banks that are suitable for growing woody riparian vegetation. Vegetated soil lifts provide bank protection when used in conjunction with a sequence of other channel bed and bank structures. Typically the structure is placed along the outer bank of meander bends exhibiting poor soil conditions and a lack of vegetation. Structure performance is dependent upon vegetation growth and placement of cuttings at elevations in contact with the baseflow water table during the growing season. The design life of the structure is temporary and intended to provide short term stability until woody vegetation becomes established. Over a period of several years, the coir products will decompose and the rooting strength of established vegetation is intended to maintain low bank erosion rates. Large woody debris (LWD) provides longer term toe protection.

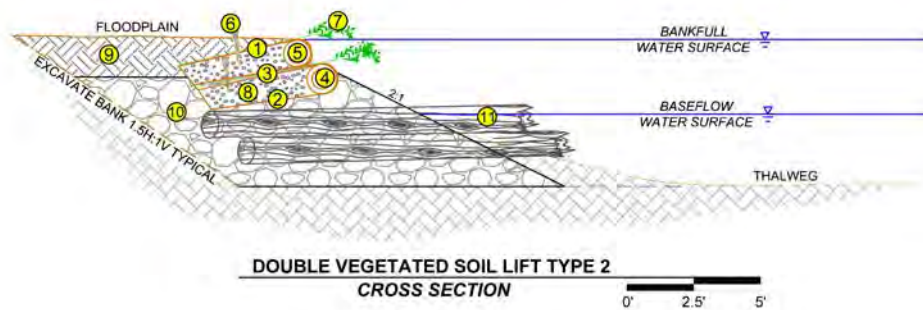

LEGEND	
① COIR MAT (SOIL LIFT 1)	⑥ WOODEN WEDGE STAKES
② COIR MAT (SOIL LIFT 2)	⑦ WILLOW CUTTINGS
③ COIR FABRIC	⑧ GRAVEL/SOIL MIX
④ COIR LOG - SOIL LIFT 1	⑨ GROWTH MEDIA
⑤ COIR LOG - SOIL LIFT 2	⑩ ALLUVIUM
	⑪ TOE LOG (NO ROOTWAD)



Pre and post construction of double vegetated soil lift on Rye Creek

SOD AND BRUSH MATRIX (Types 1 and 2)

Purpose: Revegetation, bank stabilization, channel margin roughness.

Location: Within the passive margin along riffle, run, and glide features.

Stability Criteria: Built on cobble, stem and brush toe material, sod mats with willow shoots create a stable bankline.

Habitat Attributes: Cover, shade, hydraulic complexity.

Supplemental Info: The intent of this treatment is to provide temporary bank protection along newly constructed streambanks. This treatment includes placement of wetland sod mats (Type 1) or alternating layers of sod mats (Type 2) and small diameter brush intermixed with willow cuttings to provide streambank toe protection and habitat. Willow cuttings are intended to provide shade, rooting strength, and cover along the channel margins. Typical structure placement is along straight, lower stress margins of the new channel.

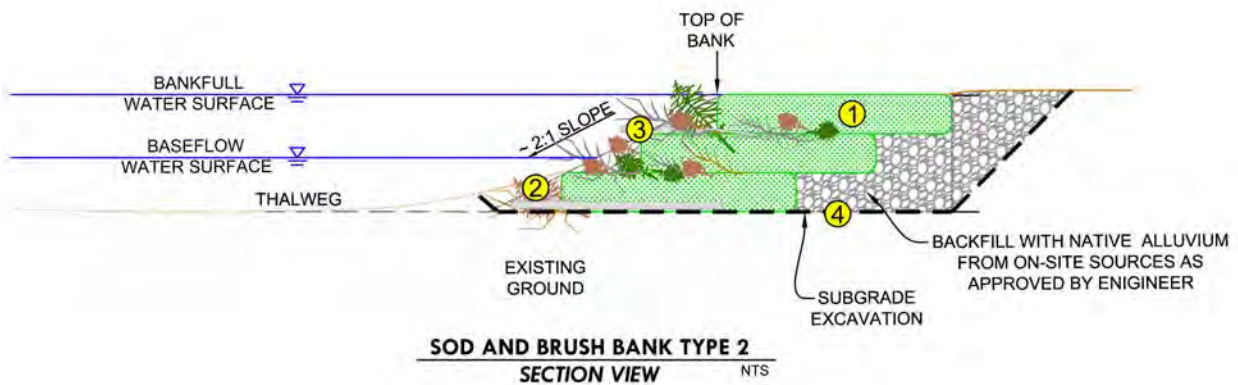
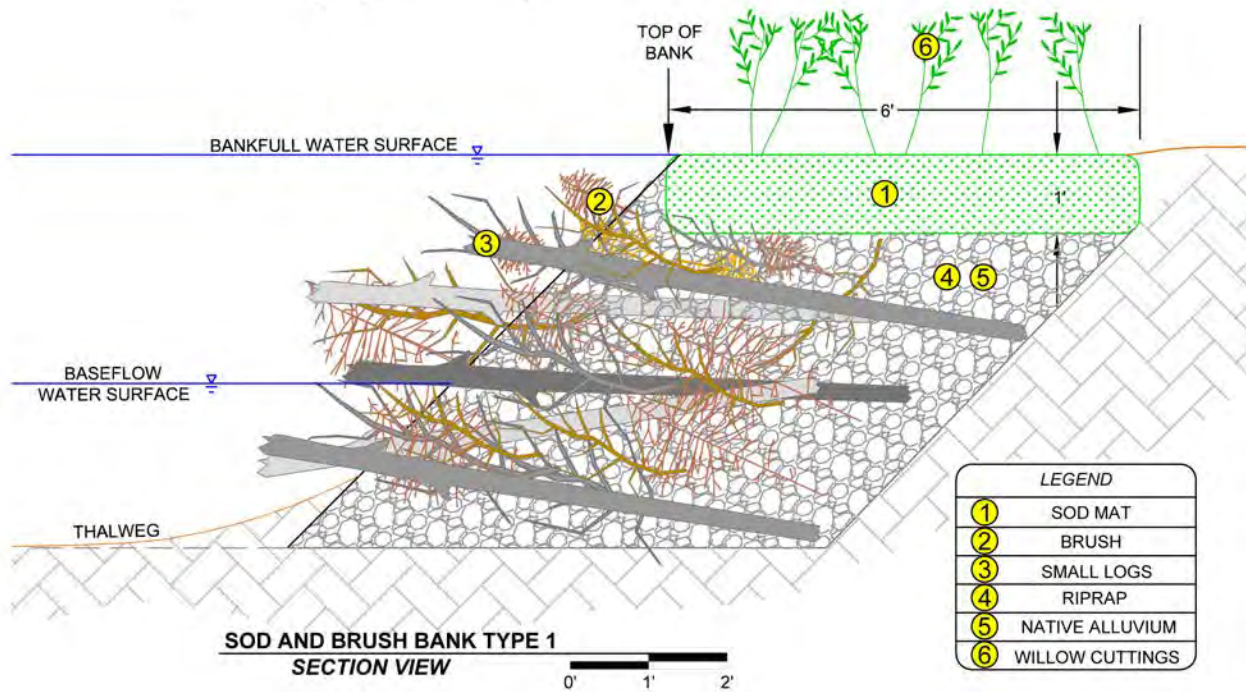

LARGE WOOD STRUCTURE

Purpose: Bank stabilization, channel margin roughness, flow redirection.

Location: Along the active margin of the outside meander bend, adjacent to pool features.

Stability Criteria: Built with large rootwads and boulders, structure is anchored to bank with large wood stems and stacked wood.

Habitat Attributes: Deep pool, cover, shade, low velocity, hydraulic complexity.

Supplemental Info: The large wood structure provides bank protection by re-directing flow away from the bank, dissipating energy, and maintaining a lateral scour pool. Typically structures are placed along the outer bank of a low-radius meander bend. Structure performance is dependent upon placement within a sequence of other channel bank and bed structures. Structure design life is temporary and intended to provide short-term stability until the project site is revegetated and recovers from disturbance. Over time the structure will decompose or become abandoned/buried in the floodplain as natural processes take over and the channel migrates across the floodplain.

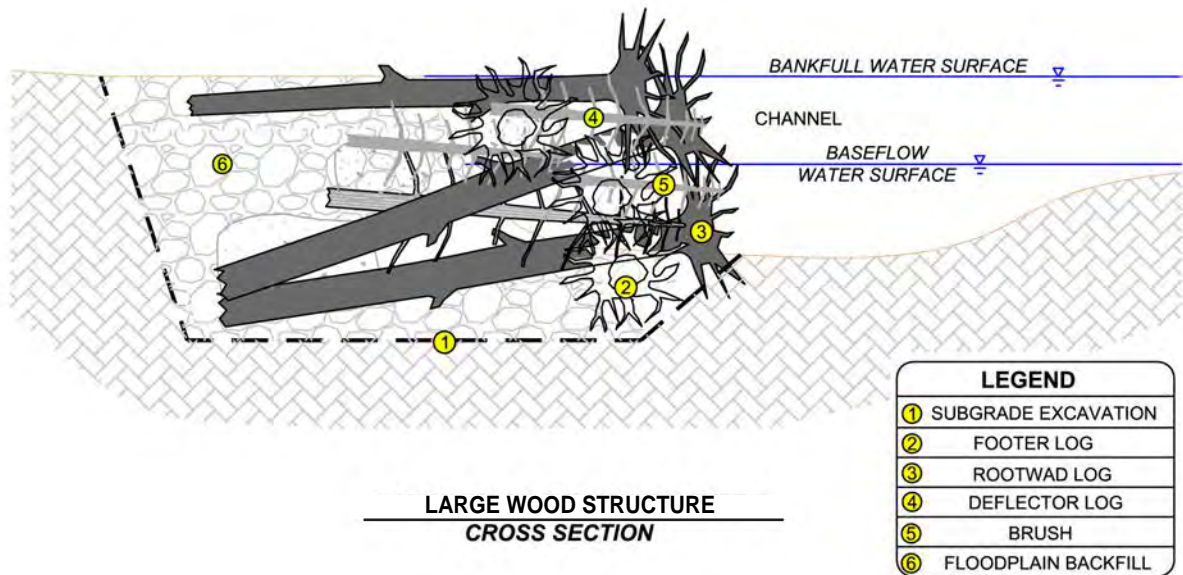

Example of a constructed large wood structure type 1



Example of a constructed large wood structure type 1

ROOT WADS / WOODY DEBRIS

Woody debris can be an effective bank stabilization treatment in many eroding bank settings. Several approaches are possible including continuous “root-rap,” individual root structures with geotextiles, and/or mature willow transplants.

Root wad protection may be appropriate when:

- Materials can be readily obtained without damage to riparian vegetation
- Bank materials are cobble/gravel and not erodible sandy textures
- Fish habitat restoration is a priority
- Careful and experienced construction techniques can be used



Root wads and woody debris can provide substantial bank protection while enhancing fish habitat. Large wood can serve as robust toe protection or incorporated into the entire bank.

Design and Construction Techniques

- Root wads/woody debris will tolerate high water velocities (greater than 10 feet per second) and erosive forces if logs and rootwads are well anchored.
- Native materials can trap sediment and woody debris, protect streambanks in high velocity streams, and improve fish habitat.
- Where appropriate, root wads/woody debris should be used with geotextile and vegetative plantings to stabilize the upper bank.
- Woody debris will have a limited life depending on climate and tree species used. Some species, such as cottonwood, often sprout and improve stability.
- The site must be accessible to heavy equipment.
- High banks (greater than 6 to 8 feet) may limit successful placement and anchoring of boles (tree trunks).
- Use root wads with 12 to 15 feet of bole. Anchor with a footer log and rocks one-and-one-half the diameter of the boles. Bole diameters should be greater than 18 inches. Larger and higher energy rivers require larger wood.

CAUTION

- Can create excessive scour and erosion with potential loss of structure if not adequately anchored
- Might need eventual replacement if revegetation is poor or soil bioengineering is not used along with the structure
- Can be expensive and time consuming to install, especially on high steep banks
- Excavation for boles can destabilize banks and damage root systems of existing trees

ENGINEERED LOG JAM

Engineered Log Jams (ELJs) are in-stream structures designed to emulate natural accumulations of large woody debris. ELJs can be designed to alter flow patterns, protect river banks, and create habitat.

Bank Protection ELJs are constructed at intervals along a river to re-direct high velocities from the near-bank. As the channel adjusts to the ELJ structures, the river bank can be left to revegetate naturally, or be restored using other bioengineering methods such as vegetated soil lifts. The spacing, size and orientation of ELJs depends on the specifics of the site, including channel dimensions, bank height, meander curvature, scour depths and other factors.

Application of ELJs provides the advantage of natural, biodegradable materials, helps create hydraulic diversity and habitat, and may integrate well into natural channel process. ELJs are best suited to sites where wood is characteristic of the stream, natural channel process is a priority, and active channel adjustments or bank movement are acceptable. ELJs are susceptible to failure by flanking or scouring, and like other methods, are particularly vulnerable on tight radius meander bends.

Construction of ELJs requires a combination of smaller and large wood pieces and some form of anchoring or ballasting. Once key piece(s) are established, smaller racking and loose members are incorporated to form a larger jam. The anchoring/ballasting can include buried stems, piles, rock, and gravel fill. In cases where public safety and property damage is a concern, an additional amount of cabling and/or ballast material may be required. Stability of ELJs requires evaluation of buoyancy, sliding, scour, or rotation, with the application of safety factors.



Constructed log jams create hydraulic diversity and can provide bank protection.



Mature log jams can collect debris over time and provide a natural element for bank protection.

CAUTION

- Avoid placing ELJs where failure of the structure could block a bridge or culvert.
- ELJs may present hazards for floaters and other recreational uses, especially on tight meander bends.
- ELJs cause active re-distribution of flow patterns, and localized scour/fill of streambeds. These can result in unintended consequences for stream stability.

BARBS / VANES

A barb is a low profile, sloping stone sill angled up-stream that can include a “j” hook at the end. Barbs help reduce bank erosion by re-directing currents away from the bank, and are commonly spaced along the bank similar to bendway weirs.

Use barbs/vanes to:

- Reduce bank protection needs (rip-rap size and quantity) and promote natural banks
- Protect banks for gentle (wide radius) meanders, or relatively straight banks
- Help deflect ice and woody debris from vegetative bank treatments while they become established



Barbs are constructed with a low sloping profile and gently “roll” the current away from the bank.

Design and Construction Techniques

- Design parameters, particularly for shape and orientation, are somewhat subjective.
- Design and installation requires a substantial amount of professional judgment.
- Spacing is variable with meander curve (75 to 150 feet is typical on major rivers).
- Key requirements included keying into the bank (15 feet typical) and bed (4 to 6 feet typical).
- Slope of barb generally replicates natural point bars.
- Length is variable with channel (up to one-quarter base flow width in some cases).
- Barb angle is variable with radius of meander curve and current approach angle (20 to 30 degrees from bank is common, but can vary according to design criteria).
- Rock size is according to shear stress and scour (2 to 4 feet rocks are typical).
- Barb elevation is variable, from matching natural gravel bars, to several feet above streambed.
- Downstream “boil” or turbulence, or upstream eddy, indicates problems with installation.

CAUTION

- Barbs are generally not appropriate for smaller rivers (less than 50 feet bankfull width).
- Erosion (“scalping”) will occur if incorrectly designed (too high, wrong angle in river, poor site).
- Barbs are not appropriate for tight radius meanders.
- Barbs often perform poorly in strongly aggrading or degrading channels.
- Design barbs for optimum performance at high flow.
- Incorrect design can cause scouring, destructive eddies along bank, and channel shifts.
- Experienced design and installation is important to success. Failure can have drastic effects to the stream.
- Expect continued maintenance to maintain intended functions.

BENDWAY WEIRS

A bendway weir is a low-profile upstream-angled stone sill keyed into the outer bank of a bed. Bendways are used to deflect flows away from the bank and can provide an alternative to rip-rap for bank protection. Bendway weirs reduce erosion by reducing flow velocities on the outer bank of the bend, and by re-directing current alignment through the bend and downstream crossing.

Applications

- Use on long reaches of relatively straight or gently curving banks that need protection
- Use to reduce bank protection needs and promote natural banks
- Bendways should be designed by an engineer and constructed by an experienced contractor



A bendway weir has a gradually sloping profile which shifts the main channel of the river to the outside of the structure. Peak flows continue to use the channel cross section above the weir elevation.

Design and Construction Techniques

- Bendway design varies according to engineering specifications.
- Bendways are keyed into the bank (15 feet is typical).
- Spacing is variable with meander curve and tangent of current streamline (150 feet is typical on big rivers).
- Slope should replicate natural point bars, and sometimes steeper.
- Length is variable with channel width, usually less than 20 percent of channel width.
- Weir angle is variable with meander curve (30 to 45 degree angle upstream typical).
- Rock size should be according to shear stress/scour (2- to 3-foot rocks are typical).
- Weir elevation is variable, from matching natural gravel bars, to several feet above bed.
- Permitting agencies will likely receive flood modeling and an evaluation of channel capacity, sediment transport, and downstream effects.

CAUTION

- Bendway weirs are generally not appropriate for rivers smaller than 100 feet bankfull width.
- Scalping (bank erosion) will occur between weirs if incorrectly designed (too high or at wrong angle in the river).
- Bendways are not appropriate for tightly meandering channels.
- Design bendways with high flow performance in mind.
- Incorrect design can cause the channel to cut a new path on the opposite bank.
- Hire consultants experienced in design and installation.
- Expect continued maintenance to maintain intended functions.

ROCK V AND W WEIRS / CROSS VANES

Rock V and W weirs are used for grade control and adjustment of width-to-depth ratio in existing or reconstructed stream channels. Upstream pointing Vs or Ws are preferred for bank protection because they provide mid-channel scour pools below the weir, which may be used as holding and feeding areas for fish.

Applications

- Use to control channel bed elevation and width-to-depth ratio
- Reduces grade and directs flows to center of channel which promotes bank stability
- Can be used for irrigation diversion
- Permanent bed elevation will not adversely affect channel stability
- Provides wide shallow channels
- Use “V” shape for narrow channels; “W” shape for larger channels
- Adequately sized rock is usually available



*This crossvane weir is designed to control width-to-depth ratio alignment at a bridge cross section. **Caution:** sediment transport can be reduced causing channel instability in high bedload rivers.*

Design and Construction Techniques

- Rule of thumb is to maintain 1.5 foot or less of drop over each structure.
- Large angular boulders are most desirable to prevent movement during high flows.
- Footer rocks keyed into the bank are required to prevent scour and undermining.
- An increased weir length will cause less fluctuation in water height with change in discharge.
- Pools rapidly fill with sediment in streams carrying heavy bed material loads.
- Boulder weirs are generally more permeable than other materials and might not perform well for diverting flows in irrigation applications.
- Designs should match natural width-to-depth ratio and avoid restricting channel cross sections.
- Downstream orientation can serve specific functions, but use caution to prevent failures.
- With center at lower elevation than the sides, weirs will maintain a concentrated low flow channel.

CAUTION

- Improper design (often excessively high elevation, construction of channel, or poor alignment) of structure can cause scouring (“whirlpool effect”) and destabilize channel.
- Weirs placed in sand bed streams are inappropriate and subject to failure by undermining.
- Weirs placed in strongly aggrading systems may become ineffective as sediments fill around structure.
- Weirs have the potential to become low-flow fish migration barriers.
- Avoid constricting high bedload channels.
- An experienced hydrologist or river engineer should assist with design of larger structures, or in unstable stream environments.
- Expect continued maintenance to maintain intended functions.

ROCK V AND W WEIRS / CROSS VANES (continued)



These large weirs eventually failed because they were built too high, and restricted sediment passage. Removal of these structures came at a high cost.



One of the structures at left, prior to failure. The warning signs were apparent, notably the elevation of apex above the bed, and 2-ft + high drop over the flat sill.



Large weirs must frequently be built in series to avoid large drops exceeding structural stability. Construction of weirs in high bedload transport streams always carries some risk of failure.



Large weirs on unstable rivers can run to over \$100,000 and still carry substantial risk of failure. Bedload deposition and scour can result in channel changes that bury weirs and scour away footings. Rivers may quickly cut new channels around the structure.



True "V" weirs generally have a row of cap rocks with spaces, rather than a flat sill. This promotes bedload passage (to some extent), but does not always work well for irrigation diversion needs.



Rock vanes can be incorporated into natural channel design to provide grade control and reference habitat conditions.

ADDRESSING STREAMBANK EROSION

RIP-RAP

Rip-rap and other hard armoring methods should be considered the last resort for stabilizing banks. Impacts on channel stability and fisheries can be substantial. Consider other options, such as root wads, geotextiles, barbs, vanes, and bendways. Where high strength is needed, use turf reinforcement mats with a rock toe.

Use rip-rap only when:

- Rigid long-term durability is needed
- Design discharge and shear stress is high
- There is substantial threat to high-value property
- Impacts to channel stability and fisheries would be minimal
- There is no practical way to incorporate vegetation or wood into the design
- Effective alternative practices are unavailable

Design and Construction Techniques

- If you must install rip-rap, use it with bioengineering and vegetative plantings to stabilize the upper bank. Techniques described on pages 3.10-3.11.
- Rip-rap areas should be vegetated to increase aesthetics and stream function. [Hoag link](#)
- The toe is the most important part of a rip-rap project. This is the zone of highest erosion.
- The key must be placed below scour depth.
- Rock is unnecessary above high water mark.
- 2:1 is the recommended slope. 1.5:1 is the steepest slope on which rip-rap will stabilize.
- Rock must be angular, not rounded, for greatest strength.
- Rock is sized according to shear stress criteria for engineered designs.
- Filter layer of gravel is needed where sandy textures will result in loss of fines through rock. Geotextile can be used but prevents root penetration where woody vegetation is desired.
- Rip-rap is flexible and not impaired by slight movement from settlement.



A well designed rip-rap job has 2:1 slopes and does not encroach on the river. This bank may have been stabilized using geotextile and vegetative methods with equal success. Note that Erosion has moved downstream below this rip-rapped bank.



An engineered rip-rap bank provides a high degree of protection, but diminishes natural river and aesthetic values. These can be enhanced by incorporating vegetation above high water mark.



The upper bank stabilized with natural geotextile fabric has been successfully revegetated for aesthetic value. Incorporating willows within the rip-rap can further enhance natural processes.

RIP-RAP (continued)



Receding bank upstream of a rip-rap job will eventually lead to failure.



Rip-rap on channelized reaches will limit the ability of the stream to re-establish equilibrium.



Concrete is generally not acceptable for large angular rock rip-rap. Contact Montana DEQ for guidance regarding use of concrete as rip-rap.



Willow can be successfully incorporated into rip-rap providing added water quality and habitat benefit.

Consider using vegetative techniques to stabilize banks whenever possible.

CAUTION

- Do not use rip-rap where vegetative or soil bioengineering methods are viable.
- Rip-rap should not extend above the bankfull elevation.
- Rip-rap can be expensive if materials are not locally available.
- Install fabric or gravel bedding to prevent piping of fines.
- The design slope should not be steeper than 1.5:1.
- The bank should be sloped back to minimize rip-rap encroachment on the river.
- Keyed rock toe and key at ends of project are essential to long term performance.
- Rip-rap may increase velocities and depth along treated bank, with substantial impacts up and downstream.
- Synthetic geotextile under rip-rap prohibits root penetration. Use a 6-8 inch layer of gravel instead.

CHANNEL RESTORATION APPROACHES

Modifying the Channel

Channel restoration involving major changes to channel gradient, location, or geometry can produce substantial benefits when properly designed. This approach can result in more rapid recovery than passive approaches but comes at a higher cost and greater risk.

Applications

- Restoring channelized or diked reaches
- Removing dams and other structures
- Relocating away from hazards and infrastructure
- Relocating due to highway construction
- Restoring channels impacted by extreme events (debris flows, mass failure, etc.)
- Restoring channels impacted by historical or modern land use (mining, logging, grazing, subdivisions)
- Creation of spawning channels or fish passage

Design Considerations

- Design of larger projects generally requires input from specialists including hydrologists, geomorphologists, wetland-soil scientists, biologists, and engineers.
- Permitting through the 404 program may allow channel restoration projects to be authorized under Nationwide Permit 27. This can help minimize wetland or stream channel mitigation requirements.
- Funding may be available to help with channel restoration projects which enhance natural stream function.



Re-establishing meanders in a channelized reach requires substantial hydrology and engineering design expertise.



Restoring natural channel width-to-depth ratio and alignment can improve stream function. This channel was over-wide from long-term grazing impacts and restored to a narrower, deeper channel cross-section.



This meander has been restored to a more narrow, deeper form by channel shaping and bank sloping/sod mats.

CAUTION

- Major modifications to channel gradient, shape, or location can be destructive if not properly engineered.
- Channel straightening is not generally acceptable.
- Relocating channels may involve delineating wetlands, floodplains, and environmental impacts that require professional assistance.
- There is a higher risk of failure than more passive approaches.

GEOMORPHIC DESIGN PRINCIPLES

The objective of geomorphic design is to restore the dimension, pattern, and profile of a disturbed river system by emulating the natural, stable river. An example design approach that employs geomorphic principles is the Rosgen classification and associated Natural Channel Design restoration techniques (Appendix 1). Measured morphological relations associated with bankfull flow (Q_{bkf}), bankfull width (W_{bkf}), geomorphic valley type, and geomorphic stream type form the basis of interpreting channel function and developing designs.



The methodology generally includes the following:

- Define specific restoration objectives associated with geomorphic process.
- Develop regional and localized information on geomorphology, hydrology, and hydraulics.
- Conduct a watershed/river assessment to determine river potential, current state, and the nature, magnitude, and probable evolution.
- Consider passive restoration recommendations based on land use change in lieu of mechanical restoration.
- Initiate natural channel design and analysis of hydraulic and sediment transport relations.
- Select and design stabilization/enhancement/vegetative treatments and materials to maintain dimension, pattern, and profile to meet restoration objectives.
- Implement the proposed design.
- Develop a monitoring plan to help evaluate effectiveness

Channel Morphology and Classification

Understanding channel form and function is key to interpreting watershed process, reach scale function, and site-specific adjustments in channel plan form, profile, and cross section.

- The Rosgen stream classification system (**Appendix 1**) defines channels according to channel metrix such as entrenchment, width-to-depth ratio, sinuosity, slope, and dominant bed material.
- These factors define eight main channel types associated with different geologic setting and valley types.
- A common channel type in Montana is a C4 channel, which is a meandering, alluvial gravel bed river with an active floodplain.
- Many stream projects are located in C4 channels, and understanding factors influencing the function of these channels is important to appropriate project design.

RESTORING CHANNEL GEOMETRY

Channel instability and bank erosion in sensitive alluvial channels is frequently related to loss of woody riparian vegetation and land use. In Rosgen C type channels, lateral bank erosion and a shift to wide, shallow channels is common. Channel instability can have adverse consequences for infrastructure, agricultural fields, diversion structures, and fish habitat. Restoration of stable channel conditions provides numerous benefits that can be fairly straightforward to implement by trained professionals. Poorly thought out projects come with additional risk that can worsen existing conditions. Restoration should rely on examination of natural reference conditions.

Strategy

1. Promote woody vegetation. This is especially important in maintaining stable channel dimensions and floodplain function. Reducing grazing pressure through riparian fencing, seasonal rotation strategies, resting, or enclosures and off-stream watering can result in rapid recovery of riparian vegetation. In time, over-wide and unstable channels will narrow and deepen as vegetation stabilizes banks.
2. Restoring reference channel cross sections, slope, and meander pattern with earthmoving and bioengineering techniques can accelerate channel recovery. This is particularly applicable to impaired stream reaches that have experienced significant channelization, down cutting, aggradation, diking, or other adverse human modifications. Stream banks and floodplain that have been fully converted to herbaceous species with any residual tree or shrub component may also benefit from active restoration strategies.
3. If required to slow lateral bank erosion, consider bioengineered vegetative treatments such as encapsulated soil lifts for eroding meander bends in pasture areas.
4. Hard structures such as rip-rap or instream rock weirs/vanes should be avoided whenever possible. Grade control for vertical instability or other considerations may warrant use of rock weirs. These require design and installation by qualified professionals to avoid adversely impacting channel function.

Natural channel design approaches such as Rosgen, NRCS, USFS, and others provide more detailed information.

CAUTION

- Streams are dynamic and respond to changes throughout the watershed, both natural and man-made. These include channel avulsions and aggradation.
- Changes to channel geometry should only be done through thoughtful planning in consultation with professional such as engineers, hydrologists, and geomorphologists as well as relevant permitting professionals.
- Projects may result in unintended consequences such as avulsions, aggradation, and flanking.
- Consider the over context of the problem and whether the proposed solution is sustainable, economically viable as compared to alternative such as no action, and/or likely to transfer the problem downstream.

AVULSIONS

Channel cutoffs (avulsions) often result from high bedload supply and deposition in strongly meandering and high width to depth ratio alluvial channels. Avulsions are part of a dynamic stream system resulting in diverse habitats over time (chapter 2). However, impaired bank stability and poor riparian health often contribute to the tendency for avulsions.

Strategy

1. **Sediment transport.** Projects rarely are able to address sediment supply on a reach or watershed scale. Instead, project must address sediment transport by reconfiguring channel cross-section, alignment, and water conveyance capacity. The objective is to reduce depositional tendency at the avulsion
2. **Channel alignment and cross-section.** Reconfiguring the channel upstream and through the avulsion site is essential. This may require a combination of adjusting the meander curvature (reducing the meander radius), reshaping channel cross section (usually narrower, deeper) through channel spilt, reinforcing meander bank with moderate to high strength bioengineering methods.
3. **Floodplain connectivity and riparian health.** The entrance to avulsion often needs to be re-configured and reinforced. The entrance to the avulsion should generally be set at or near bankfull and floodplain elevation, and not be blocked or diked to prevent overbank flows. Frequent flooding in avulsion channels is best managed by reconfiguring the main channel to address sediment transport and water conveyance.

CAUTION

Controlling avulsions can result in challenging and costly undertakings. Success is not assured even for well-designed projects. Partial solutions such as blocking the avulsion without addressing channel and floodplain function is seldom successful. Cost-benefit considerations often limit these projects to protecting high value infrastructure, or as part of large scale restoration of impaired stream reaches.



1. Reshape meander alignment and configuration
2. Reshape avulsion entrance to bankfull elevation
3. Bioengineered bank stabilization of meander and avulsion entrance
4. Revegetation of floodplain and streambanks



(Left) Aerial view and proposed treatment of avulsion
(Above) Bank stabilization under construction

AGGRADATION

Aggrading channels are common in streams with high sediment supply. Gravel deposits can fill part or all of the stream cross section and cause unconfined flooding across the floodplain. Wide, shallow channels are particularly susceptible to poor sediment transport conditions. Surface flow is often lost in aggraded channels but may resurface downstream. Aggrading channels may be inherent in the landscape (e.g., alluvial fans, transitions from confined valleys to open floodplains), or may be associated with impaired riparian condition.

In many areas of Montana, the historical logging of large streamside trees decreased upstream stability and increased supplies of large sediment causing aggradation and forcing base flows subsurface.

Strategy

1. Address upstream sediment sources if possible such as eroding banks, lateral channel instability, or off-site sediment delivery.
2. Re-shape aggraded channel to an alignment and channel cross-section which will convey sediment and water within a bankfull dimension.
3. Maintain active floodplain. Move excess fill outside of floodplain and avoid creating dykes or berms.
4. Promote recovery of woody vegetation within the floodplain.
5. Bioengineered bank stabilization may be required to maintain channel cross-section and bank integrity.



An aggraded channel can completely fill with sediment and result in frequent flooding and rapid channel migration. Large sediment supplies and impaired riparian conditions are common with aggrading channel segments.

FLANKING

Flanking, or end run of a structure (e.g., rip rap) generally occurs when flow is directed toward the bank as a result of structure placement and lack of a stable anchor point. This is often addressed by increasing the size or length or of the structure. However, it points to the need to understand the broader context of the project and the appropriate remedy.

- Lateral erosion and meander movement commonly flank small projects from the upstream end.
- Bank stabilization projects often treat short sections of eroding river bank. Property ownership boundaries, financial limitations, or other considerations may limit projects to “patching” immediate problem areas, rather than addressing the larger picture of stream planform and bank erosion.
- Key trenches of rock are often designed into projects to help counteract bank recession. Eventually, river movement can bypass key trench measures.
- Recognize that projects that treat only a portion of the meander may have a limited design life and effectiveness.
- Consider the “big” picture when looking at bank stabilization, meaning the context and probability for larger scale meander migration.

Strategy

1. Reevaluate meander progression. Is it moving downstream past project? Is it only moving laterally and not progressing downstream?
2. If the meander is tending to move downstream, and bank recession upstream is limited in extent, buying additional time may be worthwhile. Reconfigure upstream end of project. Construct vane or J-hook at upstream to help redirect current to center of channel. Make repairs to damaged bank as needed. Consider extending project upstream if viable option.
3. If lateral meander movement is aggressive and upstream bank recession is extensive, maintaining project may not be viable long term unless upstream meander can be treated.



(Left) The project site is located at the lower end of the meander, which is especially susceptible to flanking because the project addresses only a portion of the receding streambank.



(Above) Upstream end of project is being flanked as meander migrates to river right. Lateral meander progression suggests this 140 ft project will require additional work upstream to protect this location long-term.

STREAMBANK CONSTRUCTION SEQUENCE

Site Isolation/Dewatering

Dewatering the construction site can be a significant challenge in streambank restoration. Dewatering the site helps minimize release of sediment to downstream reaches, reduces potential impacts to aquatic life, and improves constructability. Dewatering techniques should focus first on limiting water entering and flowing through the site, and secondarily, minimizing pooled groundwater. Proper placement of woody debris structures and woody debris toe reinforcement is compromised by buoyancy challenges if constructed in water. Pumping standing water can assist greatly in insuring proper installation and ballasting of woody debris. A construction dewatering permit (MPDES) is required before implementation, and dewatering may be subject to timing restrictions because of fisheries.

Site Preparation

Stripping sod/topsoil and salvaging woody vegetation along the streambank is an excellent source of material for restoration. Native sod is superior to topsoil or imported materials and seeding when constructing vegetated soil lifts. The latent seed source and established root systems of herbaceous and woody species offer a distinct advantage for revegetation. Rapid establishment and protection/coverage of soils beneath geotextile fabrics is key to upper bank stability.



Ideally, in stream work can be completed “in the dry” by diverting or pumping water around the site.



Silt fence can help isolate flowing water and minimize downstream sedimentation.



Pumping water around a construction site is generally feasible only on smaller projects and smaller flow rates.



Releases of sediment during instream construction can cause substantial water quality impacts.

STREAMBANK CONSTRUCTION SEQUENCE (continued)

Toe Installation

Careful construction of the bank toe is among the most important aspects of a streambank treatment. The toe of a bank is the foundation of the project and should be composed of materials appropriate to the stream conditions (3.19). The toe must be constructed to the design scour depth often requiring excavation of a trench well below the natural streambed elevation. Placement of woody debris, brush layers, or other materials to form the underlying structure of the bank is generally below or at the elevation of the streambed. A common challenge with toe construction is water in the key trench, which hampers proper placement of woody debris, ballast rock, and fill.



Placement of large woody debris forms the foundation of many stream projects on large rivers.



Fascines and brush layering can provide a foundation for less erosive environments.



Live brush layers can be used to form a toe where scour depths are not expected to undermine the treatment.



Large woody debris foundations are typically backfilled with some amount of large rock and native fill for ballast.

ADDRESSING STREAMBANK EROSION

STREAMBANK CONSTRUCTION SEQUENCE (continued)

Brush Layers

Mixed live and dead brush layers or fascines (3.20) are often incorporated as the first layer between the toe structure and the vegetated soil lift. The brush layer provides roughness to reduce near bank velocities, and live cutting take root to reinforce the bank. Ideally, a live brush layer should have the basal end of the cuttings near the low water level, and the growing end placed at the lower limit of vegetation. The density of live stems or dead brush will vary by project. A count of 10-15 stems per linear foot, per level is common and continued irrigation increases survival. Live stems must be fresh, dormant and not allowed to desiccate in bright sunlight or during dry storage in winter. Construction in early spring, or fall is preferred to maximize cutting survival. Covering the cuttings with native fill/topsoil and watering in the cuttings with the bucket of the excavator helps solidify this layer.



A mix of live and dead brush provides bank roughness and revegetation. A high density of stems (10-15 per foot) is common.



Brush layers have the best survival when placed near the water table or in moist soils. Irrigation may be required in droughty or coarse soils.



Live cuttings should be trimmed either before or following installation.



Brush layers are placed beneath each lift of fabric.

STREAMBANK CONSTRUCTION SEQUENCE (continued)

Soil Lift

The soil lift entails layering natural geotextile fabric(s) and wrapping them over a compacted life of native backfill and a veneer of sod or topsoil beneath the fabric. Creating smooth contact between fabric and soil with sufficient staking to hold fabric tight is important, especially to prevent soil loss during high water. “Tenting” or void space under the fabric should be avoided through careful preparation of the soil surface. Any seeding must happen before the fabric is staked. The fabric segments are normally layered out constructed from the up-stream to downstream directions so the fabric seams overlap like fish scales. An individual lift should not exceed one foot in thickness.



Soil lifts are commonly installed as a single or double layer ranging in thickness from 1 to 2 feet in depth.



A completed soil lift with large woody debris toe emulates the natural range of bank roughness and stability.



Soil lifts may be constructed with multiple layers. Live brush has the best chance of establishment closest to the water table.



Installation of soil lifts requires excavating the streambank 10 or more feet.

STREAM CROSSINGS INTRODUCTION

Stream crossings have the potential to limit natural stream function, contribute to degraded water quality, and hinder movement of fish and other aquatic organisms. This chapter addresses issues specific to design of road crossings (e.g., culverts, bridges, and fords) that include factors such as channel stability, sediment, icing, and road approaches. Selection of the appropriate type of stream crossing depends on several factors including frequency of use, channel size and type, fish passage, and cost. Crossing designs for a range of flows and channel types, including flood conveyance and fish passage criteria are covered. Funding is available through state programs for improving stream crossings to increase natural stream function and fish passage.

Readers are encouraged to consult with a qualified professional to insure requirements for road crossings are met.

Contents

Road Crossings And Channel Geometry	4.2
Road Approaches	4.3
Road Crossings And Sedimentation	4.5
Flow Capacity	4.6
Planning For Bedload / Woody Debris / Ice	4.7
Culverts	4.8
Bridges	4.16
Fords	4.20

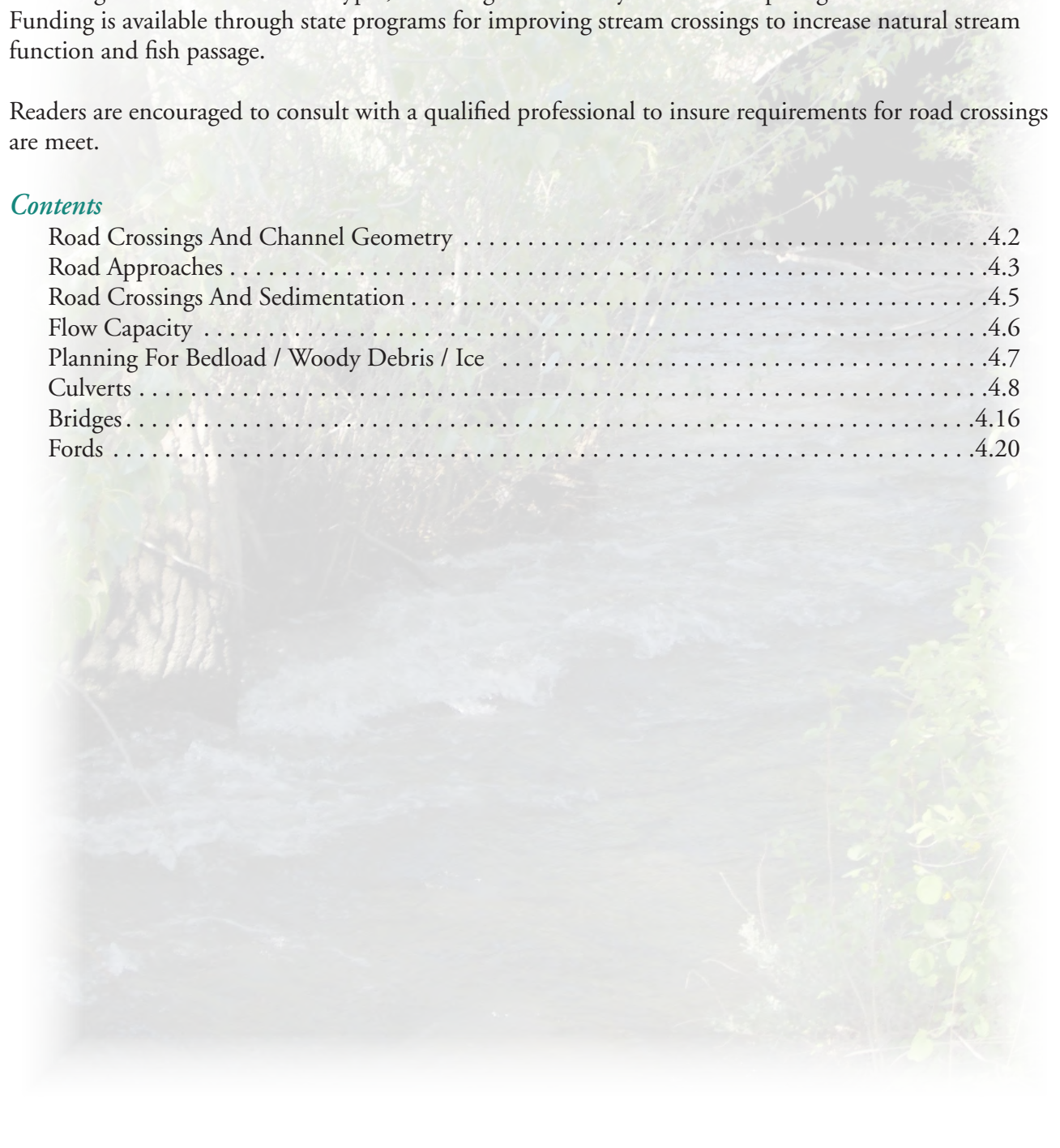

ROAD CROSSINGS AND CHANNEL GEOMETRY

Stream crossings on perennial streams include:

- Bridges
- Culverts
- Fords

Stream-crossing designs must consider:

- Channel geometry
- Peakflow capacity, scar, and erosion
- Bedload, ice, woody debris passage
- Fish passage
- Road approach grades
- Floodplain impacts (such as diking with fill)
- Relative cost
- Potential upstream and downstream effects



Choosing a location with a stable cross section is critical to project success. This failed bridge had inadequate span and was located on an actively migrating river reach. Over time, the river migrated to the west (top of photo) and the bridge location no longer matched the river alignment.

Channel Stability and Crossing Location

Channel stability and geometry must be evaluated for all stream crossings. Specifically, the design must take into account vertical (degrading or aggrading) and lateral (bank erosion and channel migration) instability.

Vertical Instability

- Downcutting can scour and undermine bridge abutments.
- Culverts control streambed elevation upstream, but downcutting may leave the outlet perched above channel. This tends to restrict fish passage.
- Aggrading channels can fill bridge and culvert cross sections and reduce channel capacity.

Lateral Instability

- Channel migration results in poor alignment of culverts and bridges over time.
- Abutments and road fill may erode with poor alignment.
- Sediment transport is interrupted by poor alignment.

Location

- Choose a crossing site in a stable, relatively straight reach of channel where possible.
- An incised (deep, narrow) channel cross section is preferred to a wide, shallow location.
- Look up and downstream of the crossing for signs of overall channel stability.
- Choose a location where the road approach will be level or slightly rising.

ROAD APPROACHES

Road approaches require planning

- Road approaches at stream crossings should be graded to rise slightly to meet the abutments. This reduces the potential for storm runoff to deliver road sediments to the channel.
- Long, steep grades and side cast fill may deliver substantial amounts of sediment to streams.
- Install proper drainage features such as rolling dips, cross drains, road crown, and ditches.
- Follow state BMPs to minimize sedimentation.
- Avoid long road approaches that form a dike across the floodplain.



Stream crossings with long, steep downhill approaches often route sediments directly to the channel.



Stream crossings on shallow channels with broad floodplains must rise to meet the bridge, or the bridge will end up being too low, like this one.

Guidelines

- Maintain road approaches at 2 percent grade or less, preferably rising to meet the abutment.
- Drainage features should be provided every 200 feet on long downhill approaches; route drainage through a filtration zone before entering a stream.
- Select a crossing location to avoid long road segments that sidecast road fill into the floodplain.
- Stabilize road fill with reseeded, slash windrows, hay bales, erosion fabric, or silt fence to prevent sedimentation of channels.



A well designed bridge spans the bankfull channel width (or more) and allows sufficient clearance for passage of flood, ice, and debris.

CAUTION

- Long, steep road approaches to the stream crossing should be avoided
- Proper drainage must be provided to avoid routing surface water runoff into stream channels
- Long, in-sloped ditches must not direct runoff into the stream or floodplain
- Avoid diking the floodplain with long elevated road approaches across broad flat valley bottoms

ROAD APPROACHES *(continued)*

When possible, road approach fill for bridges and culverts should be placed low and near the floodplain elevation so the road will be overtopped before the bridge or culvert is washed out. This allows the relatively inexpensive repair (replacing road fill or surface) instead of replacing a bridge or large culvert. By placing road approaches low, the road approach acts like an emergency spillway, passing flood waters that the bridge or culvert is unable to pass. Examples of road approach fills across floodplains and channels are shown below.

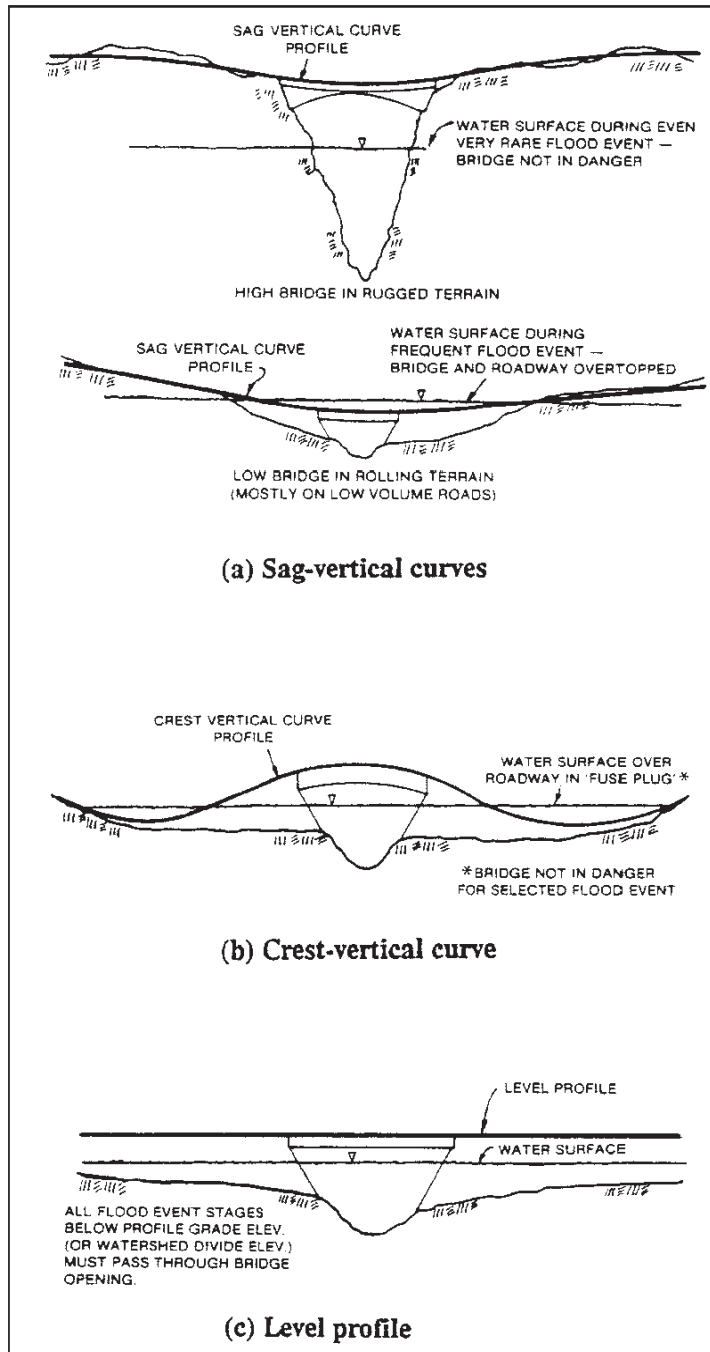

From FHWA HEC-20, *Stream Stability at Highway Structures*

ROAD CROSSINGS AND SEDIMENTATION

Roads can contribute significant amounts of sediment to streams

Erosion from roads near streams can be a significant source of sediment, harming water quality and fish habitat.

Some studies suggest that in the mountainous West, forest roads contribute as much as 85-90 percent of the sediment reaching streams in disturbed forest land.

Main Sources of Sediment

- Stream crossings (improperly designed approach grades, poorly armored culvert inlets or outlets)
- Side casting during road maintenance
- Unstable fill slopes on roads parallel to streams
- Poorly designed or ineffective drainage features (ditches, cross drains, water bars)
- Erosion from cut slopes

To avoid harm to fisheries and water quality, roads and stream crossings should be designed to reduce the potential for sediment delivery. Such projects warrant careful attention to grading and drainage. Road approaches should be kept below 6 percent grade if possible, and provided with drainage relief every 200 feet on the approach to the crossing. Vegetated swales and filter zones can reduce sediment before runoff reaches the stream. Drainage relief swales may need to be armored for long-term stabilization.

For more guidance, see Forestry Best Management Practices and the Sediment and Erosion Control Manual, which are both available from DNRC.



Poor drainage on granitic soils can deliver large amounts of sediment to streams.



Silt fence helps prevent sediment delivery on newly constructed roads, but does not substitute for proper drainage features.

FLOW CAPACITY

Instream hydraulic structures should generally be sized to handle the 100-year flood and, at a minimum, the 25-year flood. Flood peaks are estimated from regional regression equations, stream gaging stations, or measurements of channel geometry and high water marks. Regional regression equations for Montana provide a reasonably good first approximation. The USGS website includes a method called StreamStats, and enables estimation of peak flows.

Bridges

Sizing is accomplished by modeling with hydraulic programs, and evaluating backwater conditions on rivers with official floodplain mapping. County floodplain regulations generally allow no more than 0.5 foot of backwater for bridge designs.

Smaller bridge structures should seek to accommodate the bankfull channel width with a clear span, and avoid constricting the channel during major flood events (25-year or greater). Designs should pass estimated flood peaks without substantial backwater (pooling) upstream. Relief culverts may be needed in side channels or floodplain.

Culverts

At a minimum, drainage culverts should be sized to allow passage of a 25-year flood event with a full inlet. On perennial streams, consider sizing the pipe to pass the 100-year event to minimize backwater conditions. Adequate capacity is especially important on streams with high bedload transport, icing potential, or large amounts of woody debris. Culvert designs with arch, box-shaped, or round pipes with flared inlets provide better peak flow passage than standard round pipes.

Fords

Properly sited and constructed fords can replicate natural channel geometry and thus do not normally have peak flow capacity or debris problems. For this reason, fords may be a viable alternative to fixed structures in some situations.



This bridge is set slightly above bankfull, but does not have wingwalls. Location on a meander is not ideal, although upstream rip-rap limits lateral movement. Note, point bar is still growing under bridge.



This arch pipe is sized to carry the predicted 25-year flow, but causes backwater at the 100-year flow.



A well-designed box pipe enables fish passage by retaining a natural channel bottom substrate.

PLANNING FOR BEDLOAD / WOODY DEBRIS / ICE

In river systems with high bedload transport ice jams, or large amounts of woody debris, the crossing structure must allow for passage of these materials. High bedload transport channels have characteristically large width-to-depth ratios. A bridge or culvert cross section has a much lower, fixed width-to-depth ratio. Even in the absence of large backwater effects, the change in channel hydraulics through a structure can interfere with sediment transport.

Bridge and culvert design must account for:

- Probable reductions in bridge cross section and flow area with gravel deposition (or debris on piers)
- Bedload conveyance through the bridge cross section
- Potential changes in channel alignment and bank erosion in adjoining reaches
- Ice jams

Bridges are generally preferred to culverts where debris, ice, and bedload sediment concerns are substantial. Proper sizing for targeting 100-year flood conditions generally addresses bedload, debris, and ice concerns by ensuring adequate peak flow capacity. Woody debris passage generally requires 1 or 2 feet of clearance between the bottom of the bridge stringer and the high water surface. Ice passage also requires extra clearance.

A rule of thumb on smaller bridges is to allow at least 2 feet of clearance between the top of the stream bank or floodplain and the bottom of the stringer. If debris jams and icing are a problem, increase the span, do not use centerpieces, and include ice breakers on the front of piers.



This undersized culvert caused large amounts of gravel to deposit in the channel upstream. Woody debris must be cleaned frequently from the inlet.



This bridge stringer was set below bankfull, and had problems with ice jams and flow capacity.



Debris jams are often associated with center piers on bridge crossings. A clear span is preferable to piers.

CULVERTS

Culverts can perform well on stream crossings, provided they are properly sized to handle peak flows. Fish passage must be considered when selecting and placing a pipe.

Culvert Styles

- Round – standard corrugated metal or concrete pipe
- Pipe Arch/Squash – less backwater and lower final fill elevation than round pipe
- Arch – wide open bottom facilitates passage of fish, debris, and sediment
- Structural Plate – larger size of arch pipe, bridge substitute
- Plastic Round – similar to round corrugated culvert, easy to handle, but can be harder to install properly
- Concrete Box – flat concrete bottom is poor for fish passage, unless the pipe is specifically designed to retain channel bed material



Undersizing pipes to save money is a poor strategy.



Bottomless arch or box pipes (shown here) promote fish passage and create less backwater than round pipes of the same size, but can be susceptible to scour.

Design and Installation

- Size culverts to handle a 100-year flood, if possible.
- Culverts must be long enough to accommodate road fill slopes.
- Sizing is generally adequate when bankfull cross sectional area is equaled.
- Inlet water elevation at design flow should not exceed the elevation of top of pipe (no headwater).
- Place culverts on grade, or slightly below grade of stream bed ensuring natural substrate can pass through and fill the bottom
- Footings for bottomless culverts must be set well below the expected scour and frost depths.

CAUTION

- Proper siting of culvert crossings in a stable, relatively straight reach is critical.
- Culverts must adequately pass peak flows, debris, ice, and allow fish passage.
- Culvert crossings should be avoided in aggrading streams, or on laterally unstable stream locations.
- Fisheries considerations may require natural streambeds or structures to ensure passage of certain species or age classes.
- Corrosive soil or water conditions may damage metal pipe.

*CULVERTS (continued)***Culvert Placement***Headwater Channels (Rosgen A)*

- Typically steep gradient channels with deep fill over pipe
- Culvert length must be adequate to accommodate fill slopes

Mid-Valley Channels (Rosgen B)

- Moderate gradient channels, often cobble bottom with narrow floodplains
- Adequate ice and debris passage can be difficult to accommodate with pipes

Valley Bottom Channels (Rosgen C/D)

- Low gradient channels often with poor lateral stability
- Undersized pipes can cause gravel deposition and channel instability upstream
- Site selection in stable reach is critical
- Bridges and open bottom arches should be considered to accommodate channel dynamics and debris

Valley Bottom Channels (Rosgen E)

- Sinuous, narrow, deep channels, often silt or fine gravel beds with broad floodplains
- Round and especially arch pipes can work well
- Avoid raising fill across floodplain on approach road to crossing

Downcutting Channels (Rosgen G)

- Vertically unstable channels with downcutting
- Scouring downstream of pipe will leave the “downcutting” pipe perched above grade at the outlet unless the stream grade is stabilized

Appendix 1 has a complete description of Rosgen Stream Types



A well designed culvert allows for passage of flood events, and ideally, retains channel substrate material in the culvert to promote fish passage.



The shotgun (or perched outlet) culvert impedes fish passage, and can result from placing the culvert too high, or installing the culvert in a channel that has a tendency to downcut without grade control downstream of the outlet.



Multiple pipes are sometimes acceptable, but they can catch debris. Consider aluminum box or squash pipes.

CULVERT DESIGN AFFECTS FISH PASSAGE

A fish passage barrier can be anything that hinders any life stage of fish from moving through a waterway. Barriers are classified as jumping (it is too high), velocity (the water is too fast), or both. They can be considered full barriers (inhibit fish movement year-round) or partial barriers (part of the year, typically depending on streamflow). Barriers can vary based on species and life stage.

Culverts are designed to allow water to flow through them, but often do not provide adequate passage for fish or other aquatic organisms. The drawings below demonstrate key components to designing fish friendly culverts. The program FishXing is helpful when considering fish passage in a project. Information on design for fish passage, including no-slope and stream simulation culverts, are found in the following pages.

Poor Fish Passage

1. Steep culvert without grade controls to reduce slope and provide rest.
2. Flow too fast for fish to swim through.
3. Jump too high at outfall.
4. No pool at outfall entrance to assist a jump.

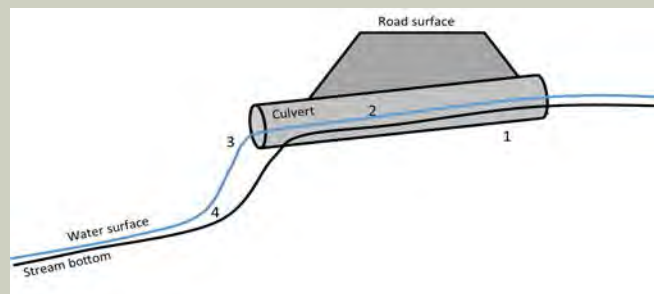

Optimal Fish Passage

1. Culvert that matches slope of channel.
2. Grade controls that provide slower flow and resting areas.
3. No jump at outfall or minimal jump with a pool.
4. Natural streambed, either with embedded or arched culvert.

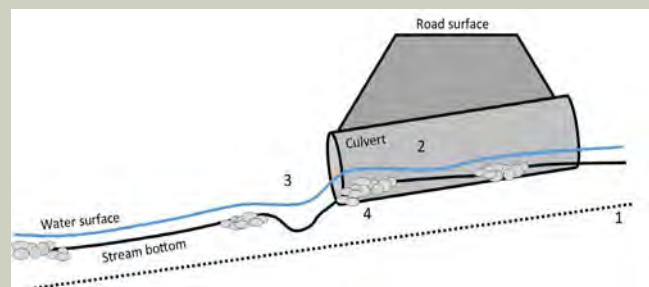

Optimal fish passage

Steeper gradient streams may require rock pools. All things being equal, shorter culverts are easier for fish to pass.

CULVERT DESIGN FOR FISH PASSAGE

No-Slope Culverts

No-slope culverts (and stream simulation culverts on the next page) are designed to simulate a natural stream-bed allow for a stable streambed inside and natural movement of bedload in some settings. Large streams over 15 feet wide will usually require a bridge.

Suitability of the site

- Small channels generally < 10 ft Bankfull Width (BFW)
- Low gradient channels generally < 3% but higher gradients may be acceptable
- Culvert installed at zero gradient
- Width of the bed in the culvert is equal to the bankfull width

Culvert type and size

- Culvert length generally < 75 ft
- Round pipes preferred to achieve embeddedness

Application

- Bottom of the culvert is set below the downstream bed 20% of its rise
- Limit the inlet countersink to 40% of the rise
- Bed placed in the culvert that is composed of material similar to the bed of the adjacent stream
- Adequate clearance between the culvert bed and crown is provided to pass expected debris during flooding events



Pipes must be designed to retain bed material. This generally requires sizing the pipe not just for hydraulic capacity but to accommodate flood events and retain bed material in the pipe.



Open bottom arches work well for larger channels, although accommodating spans more than 10 feet becomes challenging.

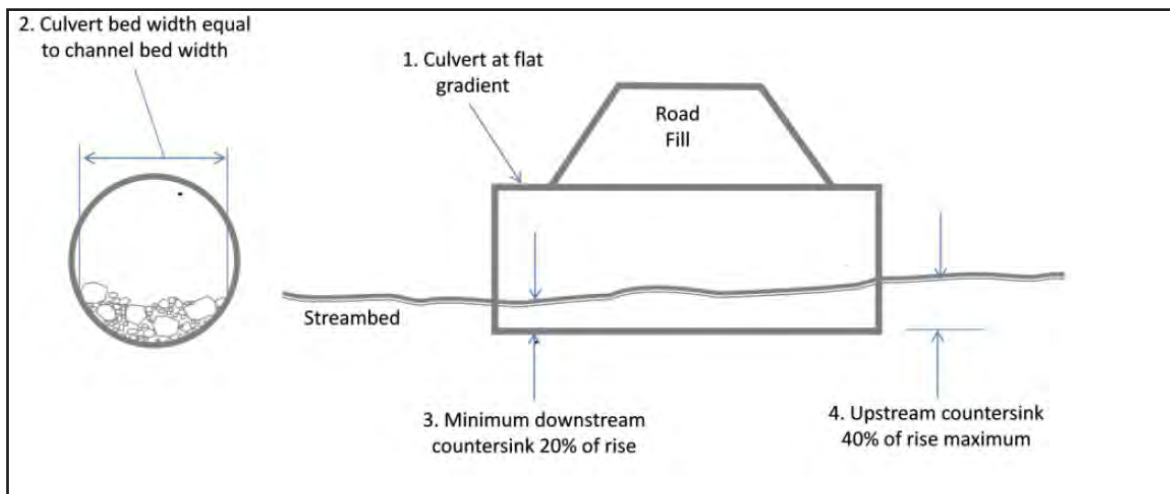

CULVERT DESIGN FOR FISH PASSAGE

Stream Simulation Culvert

Stream simulation designs create a natural channel bed and maintain channel processes within the culvert, similar to the adjacent channel. The idea being, if fish can migrate through the natural channel, they can also migrate through a man-made channel that simulates it.

Application

- Moderately confined channels
- Bankfull width less than 15 ft, with exceptions, or slope $> 3\%$
- Any equilibrium stream slope
- Stream simulation culverts with a length-to-width ratio > 10 are considered long and need special design consideration and an increase in recommended width

Suitability of the site

- Design requires geomorphic assessment of stream reach
- Method tolerates little or no lateral channel movement
- Method tolerates moderate vertical instability
- Culvert bed slope should not be greater than $1.25 \times$ upstream channel slope

Culvert type and size

- Any culvert type may be used for stream simulation
- Width of bed inside culvert = $1.2 \times \text{BFW} + 2$ feet

Channel slope less than 4%

- Countersunk culvert 30-50% of its rise
- Culvert bed should have a pool-riffle morphology
- Bed may deform, scour, reform as the natural channel does
- Coarse bands used to control channel shape, initiate stream structure



Stream simulation must ensure that bed material can be retained inside culvert. This may require hydraulic modeling and specific design criteria for material within pipe.



Note that stream simulation culverts must be 120% of bankfull width plus 2 feet.



Outlet grade control structures can sometimes be used to retrofit an existing structure and provide adequate fish passage.

CULVERT DESIGN FOR FISH PASSAGE

Channel slope greater than 4%

- Countersunk culvert 30-50% of its rise
- Culvert bed should have a cascade or step-pool morphology
- Bed tends to be stable over time
- Bed structure is built-in at the time of construction

Bed substrate design and specification

- Bed material is similar to the natural channel, although coarser substrate may be needed to increase stability
- Sediment distribution should be well-graded, non-porous, with 5-10% fines
- Sediment size can be determined by measuring the adjacent channel sediment size and/or using sediment stability analysis

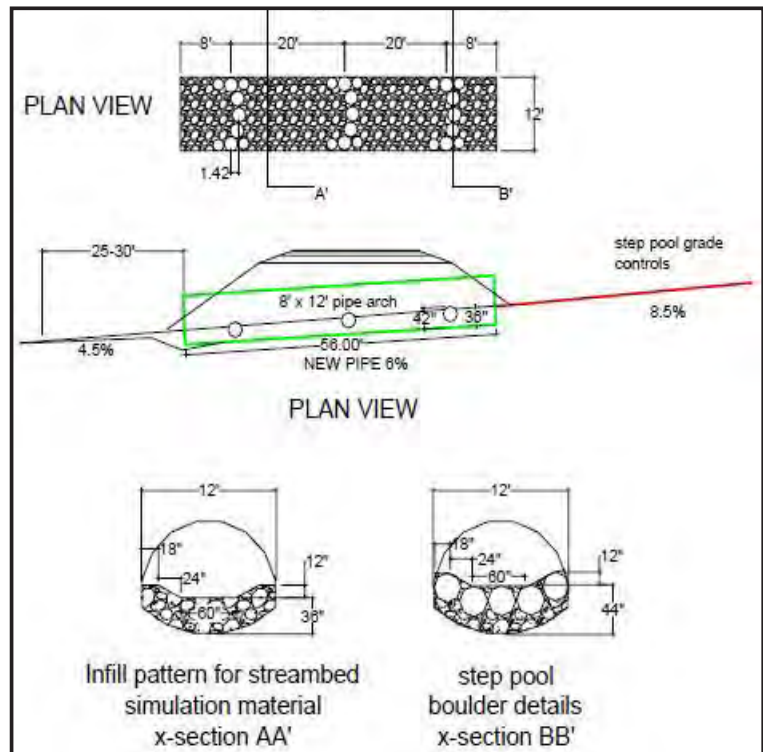

Grade control may be required at culvert outlet to prevent downcutting.

CAUTION

- Culverts must be carefully sized to retain bed material at peak flows
- Undersized culverts will impair fish passage and potentially result in channel downcutting
- In general, culverts are unsuitable for streams greater than 15 feet wide, and 10 feet may be the practical upper limit in some circumstances
- Culverts longer than 75 feet will normally require resting pools to meet fish passage criteria for all life stages
- Resting pools are difficult to incorporate into most designs; and, therefore, bridges are a preferred option

GUIDELINES FOR CULVERT DESIGN

Culvert and road crossing design needs to consider: 1) the ability to pass peak flows, sediment, woody debris, ice and fish; 2) ability of structure and road fill to accommodate flooding and minimize backwater; 3) accommodate specific provisions for fish/aquatic organism passage as required by agencies.

- 1. Design Peak Flow.** Peak flow for flood events can be estimated from the USGS program called StreamStats. This interactive, online application enables the user to select a stream location from a map. The program defines a watershed area and provides estimates for a range of flow conditions. These estimates include peak flows of different return intervals (e.g. 25-yr and 50-yr flood), low flow estimates, or monthly values.
- 2. Design Flow Capacity.** Culverts that are not required to provide fish passage should generally be designed to pass the 25-yr flow. In some cases, passage of the 100-yr flood is recommended, or may be required by permitting agencies.
- 3. Fill Height.** This is the total height of the road fill, as measured from the channel bottom to the road surface. This value is used in calculating culvert length.
- 4. Road Width.** Top width of the road is typically 12-14 feet for single lane road. This value is used to calculate total culvert length.
- 5. Culvert Length.** A first approximation of culvert length with fill slopes of 1.5:1 is equal to road width + (3 x fill height). In most situations this allows for sufficient length to accommodate road fill slopes.
- 6. Channel Depth.** Bankfull depth as measure from the channel bottom to the active bankfull floodplain. Identifying bankfull depth from the channel bottom can help define the width of channel that will be expected to flood every 1.5 to 2 years.
- 7. Channel Width.** Culverts should span the entire bankfull width at a minimum to allow passage of fish, peak flow, sediment, debris and ice. Guidelines for fish passage may require widths in excess of bankfull (i.e., stream simulation culverts) for channels > 5 ft wide, or slopes > 2%.
- 8. Culvert Type.** Culvert shape (round, arch, box) and material (metal, concrete, plastic) should be identified.
- 9. Culvert Diameter (span).** The width of the culvert should generally span the bankfull width, particularly if fish passage is required, or heavy woody debris loads/icing are common.
- 10. Culvert Embeddedness.** The depth the culvert will be embedded into the streambed, if required for fish passage. Note, a culvert should not be buried below stream grade if it is not properly sized to accommodate flood events, or the full bankfull width of the channel. An undersized culvert can result in scour and stream bed downcutting in alluvial channels.
- 11. Provision for Fish Passage.** Culverts should be designed to provide a means of fish passage. This is particularly important in high value fisheries including tributaries that provide spawning and rearing habitat. Guidelines for fish passage are found in the road crossing section of this guide, and also in the State of Washington Water Crossing Design Guidelines (2013). In general, the upper practical limit for culverts is a 10-12 foot span at which point bridges become the preferred approach. The MFWP fish biologist that consults on the 310 permit can help select options.

Culvert Design

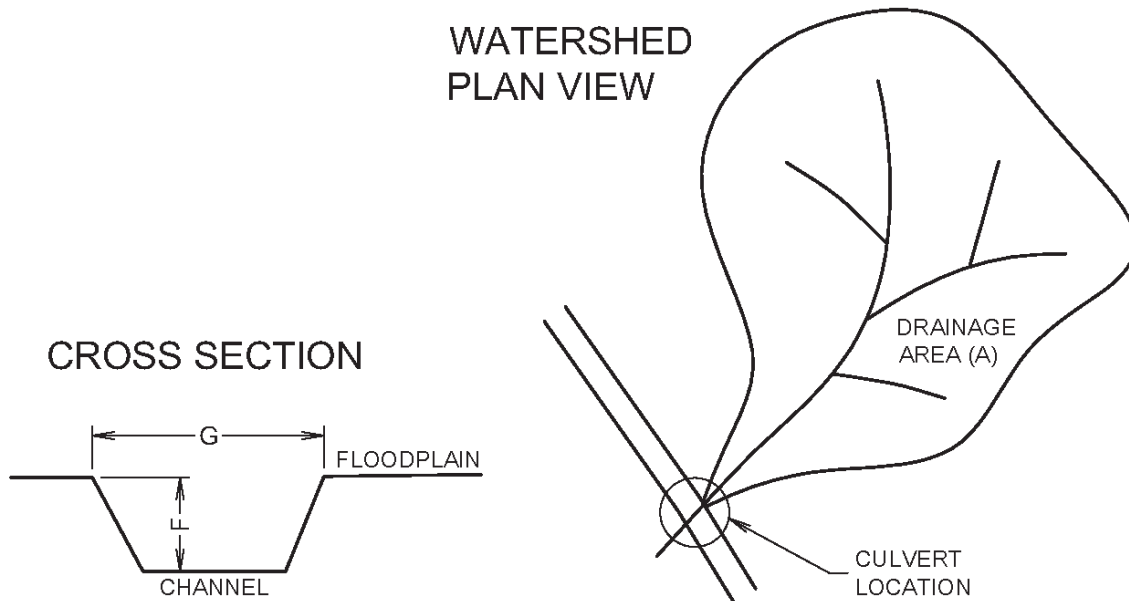

- | | |
|--|---|
| 1) DRAINAGE AREA (sq. miles) A = _____ | 6) CULVERT LENGTH (C+(3xB)) (ft) E = _____ |
| 2) PRECIPITATION (IN) ppt = _____ | 7) CHANNEL DEPTH (ft) F = _____ |
| 3) DESIGN 25 YR. 100 YR. FLOOD, (cfs) Q = _____ | 8) CHANNEL WIDTH (ft) G = _____ |
| 4) FILL HEIGHT (ft) (CHANNEL BOTTOM TO ROAD) B = _____ | 9) CULVERT TYPE (ROUND, ARCH, BOX, _____) |
| 5) ROAD WIDTH (ft) C = _____ | 10) CULVERT DIAMETER (in) D = _____ |
| | 11) PROVISION FOR FISH PASSAGE _____
ZERO SLOPE PIPE, STREAM SIMULATION PIPE, AT GRADE |

PROFILE

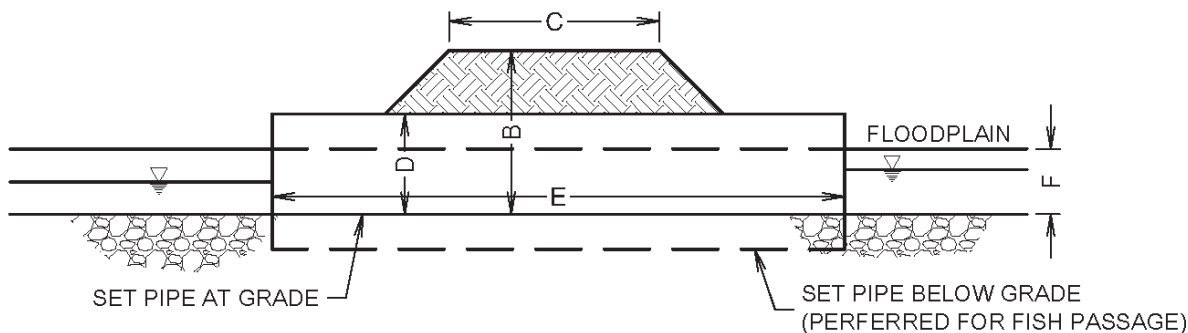

PERMIT NO.:	DATE:	LOCATION:	PROJECT NAME: CD Manual
PROJECT MANAGER:	NOT TO SCALE	FILENAME:	DRAWING TITLE: CULVERT DESIGN TEMPLATE
DRAWN BY:	CHECKED:	FIGURE:	

BRIDGES

Well designed bridges are the preferred option for permanent stream crossings because they usually have the least impact on channel process and fish passage. Bridge deck drainage should be directed to bridge ends to avoid direct stormwater runoff containing sediment, salt, or other pollutants from discharging directly into state waters. Most bridges should be designed by an engineer, with hydraulic and structural analysis.

Typical Small Bridge Construction

Timber

- Timber bridges are most applicable to stream crossing up to about 30 feet.
- Timber is suitable for light load requirements.
- Stringers can be raw logs, milled beams, or laminated beams.
- Raw log abutments can be labor intensive.
- Equipment needs for construction are modest.

Steel

- Railcars can be used for bridges 30 to 65 feet. Longer spans usually require piers.
- Use steel I-beam, wood, or corrugated steel decking for 20 to 100+ ft. spans.
- Long project life is an advantage of steel.
- Steel allows a longer clear span than timber, reducing need for center piers, which can catch debris.

Concrete

- Typical small bridge design is a pre-stressed slab with poured concrete abutments.
- Use beam construction for larger bridges.
- Heavy load capacity and minimal beam depths for the slab (vs. stringers and beams) are an advantage.
- An engineered design is usually required.



This well-designed bridge has adequate clearance for ice, debris, and peak flows. Note, however, that the abutments do encroach on the channel somewhat.



Railcar bridges are popular and fairly solid, but often are not installed properly. This one is set low relative to bankfull, but it is a temporary installation.



The structural beam on many railcars hangs low and ends up falling below bankfull elevation, which presents risks during high flows.

BRIDGE ABUTMENTS AND PIERS

Abutments

- Abutment design must account for scour depth in the stream bed to prevent undermining of footings.
- Generally, the minimum depth for footings is below the frost line and piers should be well below the lowest point of the streambed at the crossing.
- Footings may need to extend 10 feet deep or more in unstable rivers.
- For most smaller bridge projects, observing the depth of nearby pools gives a good indication of minimum footing depth.
- Abutments can be constructed from a variety of materials, and should include wingwalls to stabilize road fill on the approaches.

Bridge Piers

Avoid designs with piers if possible because they tend to catch debris, causing scour and channel instability during peak flows.

- Wood spans exceeding 30 feet, or steel spans approaching 50-60 feet, require piers for support.
- Longer bridge spans requiring heavy load capacity should have an engineering review.



A well-constructed abutment has adequate wingwalls to support road fill.



Concrete can make good abutments, provided the footing is placed below scour depth. This footing should be 2 feet lower.



A low stringer in an aggrading channel does not leave much room for water. Note that the beam hangs low in the center and restricts peak flow capacity and debris passage.



Concrete abutments are generally preferred, and must be protected from scour at the toe. Note the silt fence in place during construction to minimize turbidity.

GUIDELINES FOR BRIDGE DESIGN

Bridge and road crossing design needs to consider 1) the ability to pass peak flows, sediment, woody debris, ice and fish, 2) ability of structure and road fill to accommodate flooding and minimize backwater, 3) accommodate specific provisions for fish/aquatic organism passage as required by agencies.

- 1. Design Peak Flow Capacity.** Peak flow for flood events can be estimated from the USGS program called StreamStats. This interactive, online application enables the user to select a stream location from a map. The program defines a watershed area and provides estimates for a range of flow conditions. These estimates include peak flows of different return intervals (e.g. 25-yr and 50-yr flood), low flow estimates, or monthly values. In larger streams and rivers, flood flows and elevations may already have been established FEMA studies and maps (Digital Flood Rate Insurance Maps). Contact your local floodplain administrator to determine if your project is in a mapped floodplain. Specific design criteria and hydraulic analyses are required in mapped floodplains. Bridges that are not required to provide fish passage or meet FEMA criteria should generally be designed to pass the expected 25-yr flow. In most cases, unimpeded passage of the 100-yr flood is recommended, and may be required by permitting agencies.
- 2. Bankfull Width.** At a minimum, bridges should generally span the entire bankfull width to allow passage of fish, peak flow, sediment, debris and ice.
- 3. Span.** The bridge span is the length of the deck after subtracting any fill slopes beneath the bridge. Note that the deck length and the available room for the channel may differ greatly if the abutment fill slopes encroach on the channel. Plan to make the span wide enough so the fill slopes do not encroach on the channel.
- 4. Stringer/Bankfull Clearance or Freeboard.** The clearance between the bottom of the bridge and the design high flow flood event should allow for sufficient room to allow passage of ice, woody debris, and floaters. A rule of thumb is to allow a minimum of 2 feet between high flow and the bridge stringer.
- 5. Abutment Footing Depth.** The footings should be placed below the expected scour depth of the stream. The deepest pool in adjoining stream reaches can give an idea of probable minimum scour depth.
- 6. Bankfull Depth.** Bankfull depth as measured from the channel bottom to the active bankfull floodplain. Identifying bankfull depth from the channel bottom can help define the width of channel that will be expected to flood every 1.5 to 2 years. This is generally a minimum width for bridges.
- 7. Road Width.** Top width of the road is typically 12-14 feet for single lane road.
- 8. Wingwall Length.** A first approximation of minimum wingwall length with fill slopes of 1.5:1 is equal to (bankfull height + clearance) x 1.5. In most situations this allows for sufficient length to accommodate road fill slopes.
- 9. Bridge Type.** Bridge type and materials should be identified. A Professional Engineer or qualified professional should be consulted to insure bridges will support required loads.
- 10. Abutment Type.** Abutments can be constructed as retaining walls, re-inforced fill slopes, pilings, or a combination or techniques.

Bridge Template

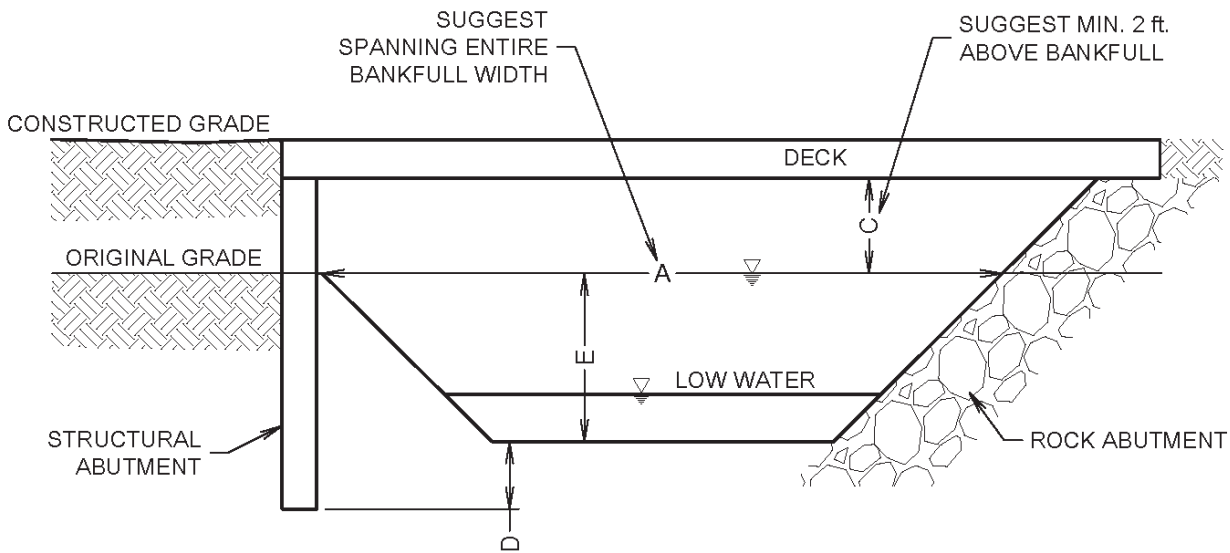

- | | | | |
|-------------------------------------|-----------|-------------------------------------|-----------|
| 1) BANKFULL WIDTH (ft) | A = _____ | 6) ROAD WIDTH (ft) | F = _____ |
| 2) SPAN (ft) | B = _____ | 7) WINGWALL LENGTH (D+E+C)x1.5 (ft) | G = _____ |
| 3) STRINGER/BANKFULL CLEARANCE (ft) | C = _____ | 8) BRIDGE TYPE | _____ |
| 4) ABUTMENT FOOTING DEPTH (ft) | D = _____ | 9) ABUTMENT TYPE | _____ |
| 5) BANKFULL DEPTH (ft) | E = _____ | | |

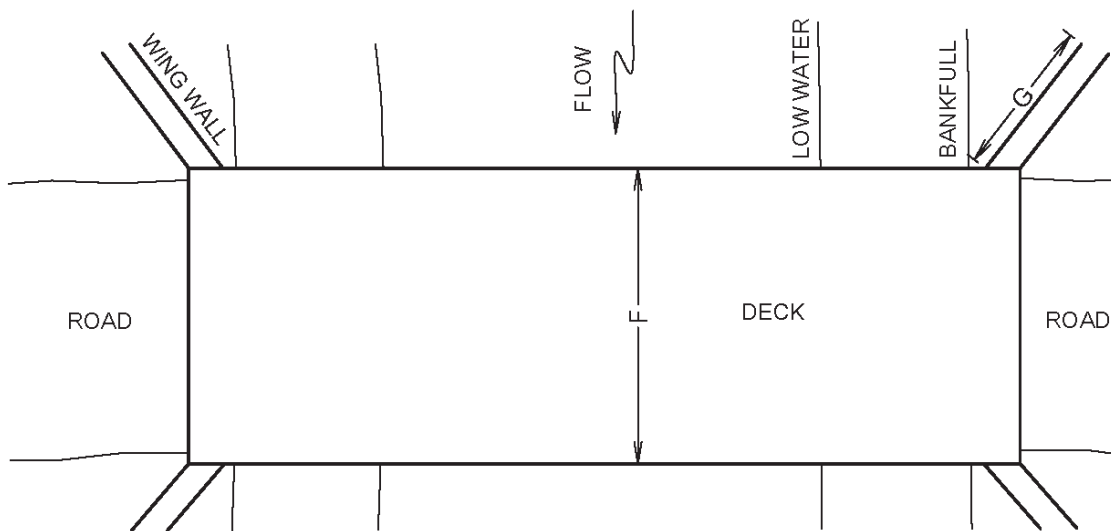

PERMIT NO.:	DATE:	LOCATION:	PROJECT NAME: CD Manual
PROJECT MANAGER:	NOT TO SCALE	FILENAME:	DRAWING TITLE: Bridge Template
DRAWN BY:	CHECKED:	FIGURE:	

FORDS

Fords are used as a temporary crossing in wide shallow channels with gravel or cobble bottoms and infrequent traffic.

Applications

- Temporary crossings
- Gravel/cobble bottoms/light traffic
- High width-to-depth ratio channels
- Emergency access
- Only used if impacts to channel stability, fisheries, and water quality are minimal

Design and Construction Techniques

- Unreinforced fords can be effective in solid substrate with light traffic.
- With heavier traffic or softer gravel channel bottoms, channels generally require some type of reinforcement.
- Reinforcement materials include rock, timber, concrete plank, geogrid, and filter fabrics.
- Size rock to resist scour and stream shear stress.
- Use filter fabric to prevent pumping rock into soft channels.
- Geogrid rock/gravel filled mats, or fabrics are designed according to load requirements.
- Timber can be used for temporary crossing on small channels (such as winter logging with snow bridge over logs).
- Match the natural cross-section of the stream as closely as possible to protect streambed stability.



Fords may be a viable alternative for intermittent channels or channels that are shallow and wide and resist other solutions.



To protect water quality, avoid fords on perennial channels with poor approaches and inadequate drainage control.

CAUTION

- Fords are not appropriate for deep, narrow channels (E type) or soft channel bottoms without reinforcement.
- Fords are usually not appropriate as permanent installations unless traffic is very infrequent.
- Channel dynamics can be impaired if the ford cross section does not match natural channel cross section.
- Sediment releases, associated with traffic, may cause unacceptable harm to fisheries.
- Fords may be subject to travel restrictions.
- Road approaches must not direct road surface runoff into channel.

IRRIGATION DIVERSION STRUCTURES

Irrigation diversions are an important tool to ensure access to surface water rights. By ensuring proper siting and construction of diversions, irrigators can ensure that their activities will limit the impacts to natural stream function and to native fish populations. This chapter addresses design considerations, different types of diversion structures, and fish passage issues. Each structure is unique to the stream context and the needs of the irrigator as well as their allocated water right. Therefore, consultation with a professional is encouraged to ensure structures function efficiently and effectively to meet the needs of landowners and natural resources.

Contents

Design Considerations for Irrigation Structures	5.2
Concrete / Wooden Pin & Plank Diversions	5.3
Engineered riffle Diversion.	5.4
Rock Weirs & Vanes.	5.5
Gravel Berm Diversions	5.6
Diversion Blocks	5.7
Inflatable Gate Diversions	5.8
Infiltration Galleries	5.9
Fish Passage at Diversions.	5.10
Guidelines for Small Diversion Design.	5.12
Headgates.	5.15
Fish Screens	5.16
Flow Measurement Devices	5.20
Dams and Spillways	5.22



Careful design helps reduce impacts to the stream and cuts maintenance costs on irrigation diversions



Fish screens on diversion structures prevent the loss of fish in irrigation ditches (entrainment)

DESIGN CONSIDERATIONS FOR IRRIGATION STRUCTURES

Stream Form and Function

- Diversions should accommodate natural stream geometry and channel dynamics.
- Evaluate stream width-to-depth ratio, and match these dimensions if possible.
- A peak flow capacity for a 100-year event is recommended for most diversions.
- Diverting water leaves less water in the stream to carry the same sediment load, and can lead to aggradation and channel instability.
- Changes in irrigation diversion location (or place of use) may require filing a change with the DNRC.

Channel Stability and Capacity Considerations

- Ensure that vertical and lateral channel stability is adequate for long-term stability.
- Evaluate effects of a permanent rock weir vs. removable structure (permanent structures may aggrade).
- Permanent instream structures should not restrict channel capacity when not diverting water.

Period of Diversion

- High Water Operation – ability to regulate peak intake rates is important to prevent ditch failures
- Low Water Operation – maintaining sufficient head to fill ditch can be challenging as stream drops
- Year Round Diversion – icing and regulation of flows may make year-round diversions difficult
- Type of Structure – permanent and temporary structures each have advantages

Headwater Elevation Required

- Required ditch operating elevation and high/low water elevations in the stream should be estimated.
- “Checking up” of water should be kept to the minimum height to divert adequate irrigation water.
- Diversions requiring minimal checking of stream elevation include rock weirs, barbs, and temporary cobble berms.
- High head installations require structural methods, and may have greater impacts on channel stability.
- High head and even low head structures can pose a hazard to boaters and anglers.

Fish Passage

- Fish passage can be impeded by structures with drops exceeding 1 foot, or drops with poor entrance conditions and staging pools. Different fish species and age classes have varying requirements.
- Flat sills or diversion floors downstream of drop structures impede fish passage.
- Low head structures can be more successful for fish passage.
- High head structures can require modification to facilitate fish movement.
- Fish ladders can be incorporated into the design if water availability is adequate to allow a flow of several cubic feet per second to continue past the diversion.
- In some cases, a “wasteway” ditch for return of excess diverted water can provide fish passage around an irrigation structure.
- Fish screens can be used at irrigation inlets to prevent fish from entering when biologically relevant.

CONCRETE / WOODEN PIN & PLANK DIVERSIONS

Traditional pin and plank diversions are common in Montana, but often impede fish passage, and can adversely impact channel process. Nevertheless, they find application under certain circumstances.

Applications

- High head check structures (greater than 3 feet)
- Low width-to-depth ratio channels
- Locations where water cannot be checked up to needed elevations year round (e.g., excessive backwater/flooding, icing, debris).

Design and Construction Techniques

- The open area of an unchecked diversion should accommodate the bankfull width of the stream.
- Structures should not impede floodplain function.
- Collapsible braces are recommended in streams that carry substantial amounts of woody debris or have a history of ice jams.
- Keep stopboards under 4 feet in length for ease of handling.
- Wingwalls must be of adequate length to retain fill materials.
- Provisions for fish passage should be considered.
- Standard designs are available through NRCS offices.



Concrete may be preferred to wood for longevity. This structure is not fish friendly because of the height of the drop and the flat slab downstream.



Wooden diversion structures have a limited life but are easily constructed. These type of diversions often form fish barriers because of the stopboards and flat floor.

CAUTION

- Backwater can cause bedload gravel to accumulate, destabilizing the stream channel.
- Icing and spring peak flow can damage the structure if flashboards are left in place.
- It may be difficult to adjust or remove stop boards during spring floods.
- Fish passage is likely to be impeded unless mitigation measures are designed into the structure.
- Avoid restricting the channel cross section with abutments.
- Avoid placing a sill or slab above or below the grade of the existing stream channel.
- Avoid creating boating hazards, if possible.
- Potential alternatives are engineered riffle diversion or rock weirs.

ENGINEERED RIFFLE DIVERSION

Engineered riffle as an Alternative to Pin & Plank

A engineered riffle structure can provide an alternative to pin and plank diversion structures. In lieu of vertical stop boards, a rock structure can be constructed across the channel. This can be a long riffle or sequence of riffles and weirs or boulders.

Ideally, diversions should be designed to accommodate the transport of flow, sediment, and aquatic organisms. This requires an understanding of the sediment and flow regime of the stream/river, and fish passage requirements for the target species.

The photographs show replacement of a pin and plank structure with a engineered riffle and rock weir. The engineered riffle is self-maintaining and does not require adjustment as river stage increases or decreases. In addition, a mechanical paddle wheel fish screen was installed with a sediment sluice to keep the forebay clean of sediment. A fish return pipe was designed to prevent fish entrapment in the irrigation ditch.

Design Considerations

- Understand the sediment and flow characteristics of stream.
- A engineered riffle or weir is a permanent rise in channel bed elevation. Effects on flood elevation and sediment transport must be considered.
- Diversion should accommodate natural stream geometry and channel dynamics.
- Required ditch operating elevations and high/low flow elevations in the stream channel should be evaluated.



Original stopboard structure and Denil ladder did not provide adequate fish passage.



The diversion in the photo above was replaced with a engineered riffle structure, which allows fish passage and maintains natural stream processes.



View of the diversion weir, engineered riffle, new radial headgate and flat panel fish screen.

ROCK WEIRS & VANES

Rock weirs are used for grade control and can provide a means of diverting irrigation water in situations where a permanent structure will not cause problems with channel stability. They can perform comparably to engineered riffle diversions. Like engineered riffles, weirs and vanes need to be evaluated for potential effects on flood elevations and sediment transport.

Rock weirs are appropriate on wide shallow channels where adequately sized rock is available. Use a “V” shape in narrow channels and a “W” shape in larger channels.



*This weir has a relatively flat profile (without “cap” rocks) typical of an installation to check water at irrigation diversions. **Caution:** sediment transport can be reduced, causing channel instability in high bedload rivers.*

Applications

- Control channel bed elevation
- Help guide water to ditch entrance
- Raise water elevation at ditch intake
- Promote bank stability by reducing grade and focusing flows to the center of the channel

Design and Construction Techniques

- Rule of thumb is to maintain a 1 foot drop or less over each structure.
- Large angular boulders are best to prevent movement during high flows.
- Use footer rocks to prevent scour and undermining.
- Increased weir length means less fluctuation in water height with changes in discharge.
- Pools will rapidly fill with sediment in streams transporting heavy bed loads.
- Boulder weirs are generally more permeable than other materials and might not perform well for directing low flows.
- Voids between boulders can be chinked with smaller rock and cobbles to maintain flow over the crest.
- With center at lower elevation than the sides, weirs will maintain a concentrated low-flow channel.
- Permitting on streams and rivers with mapped floodplains may require detailed hydraulic analyses to comply with no-rise requirements.
- Changes in the base flood elevation may trigger CLOMR/LOMR process, particularly if the diversion was not included in the FEMA floodplain study.

CAUTION

- In-stream structures can reduce sediment transport capacity and can severely impact the channel.
- Potential effects on flood elevations must be evaluated in jurisdictional floodplains.
- Elevation drop of more than several feet increases the risk of scour and structural failure.

GRAVEL BERM DIVERSIONS

Annual construction of gravel berms for irrigation diversions in rivers using heavy equipment has generally been discouraged by permitting agencies. Depending on how much site disturbance is needed, impacts on channel stability and fisheries can be substantial.

Gravel berms may be appropriate:

- When impacts to channel stability and fisheries are judged to be minimal
- On larger braided rivers where permanent structures are not feasible
- When alternative practices are unavailable

Alternatives

- Ditch cleaning to improve capacity
- Low head rock weirs
- Relocation of ditch entrance upstream
- Use of concrete diversion blocks
- Conversion to pumping station
- Infiltration galleries (generally less than 5 cubic feet per second)

Design and Construction Techniques

- The gravel berm should be constructed to the minimum level needed to divert water.
- No gravel should extend above low water elevation.
- The length of berm and encroachment into the channel should be kept to a minimum.
- The berm should be knocked down after the irrigation season to reduce impacts to the river channel.
- Minimize disturbance of streambanks and vegetation when using heavy equipment.



Gravel berms are essentially an extension of the ditch. Relocating the ditch entrance upstream may reduce the need for instream berms.



Berms can direct flow against the opposite bank and cause erosion on the other side of the river.



Small temporary berms may be appropriate in some locations as a low-impact alternative to permanent structures.

CAUTION

- Leaving permanent berms in place can destabilize stream channels.
- Construction of berms can disturb incubating eggs and spawning fish.
- Alternatives to berms should be considered whenever feasible.

DIVERSION BLOCKS

Concrete diversion blocks provide an alternative to permanent structures in the river bed or temporary gravel berms. Concrete blocks are placed on the river bed for the irrigation season, and removed in the fall. Blocks can be placed with a backhoe or loader using a lifting eye. Blocks are typically oriented in the upstream direction – not across the channel - effectively extending the “ditch bank” and point of diversion upstream on the river.

In high width to depth channels (i.e., wide and shallow), concrete blocks may eliminate the need for excavation and disturbance of the channel bed with annual construction and removal of berms. Not all locations are suitable for this style of structure, and depending on the location and channel alignment/morphology, some preparation of the stream bed may be needed. Gravel bed rivers (Rosgen C and D channels) can lend themselves well to this application.

One advantage of removable concrete blocks is that floodplain permitting for diversions with FEMA mapped floodplains may be expedited by virtue of the temporary installation that leaves flood elevations unaffected. Bedload also passes freely during peak flows, which reduces the potential for aggradation and channel instability. Finally, the orientation of the blocks can be modified each year to accommodate shifts in channel orientation and low flow pathways.

Design and Construction Techniques

- Diversion blocks should be placed in the upstream direction, not across the channel.
- The channel bed will need to be prepared (smoothed/leveled) with backhoe or excavator.
- The length of blocks and encroachment into the channel should be kept to a minimum.
- The blocks must be removed after the irrigation season to reduce impacts to the river channel.
- Minimize disturbance of streambanks and vegetation when using heavy equipment.
- Storage of blocks within the floodplain may be acceptable if they do not create hazards during flood.



Concrete diversion blocks have a lifting ring and when placed in the streambed, the broad base keeps the block from tipping. Some site preparation may be necessary.



Blocks can reduce the need for streambed disturbance associated with gravel berms. Blocks should be removed following irrigation season.

CAUTION

- Blocks should not be left in place year-round because of the potential for channel impacts.
- Scour and fill during high flow may bury blocks in the streambed.

INFLATABLE GATE DIVERSIONS

Inflatable rubber or fabric bladders are most common as spillway control structures on dams. Inflatable bladders can also be used alone without permanent structures for temporary diversions at construction sites or to control flooding. Both structurally supported and unsupported bladders may serve as irrigation diversions.

Use inflatable bladders:

- When precise control of headwater conditions is needed
- When automatic control is desired
- As an alternative to berms
- To allow the release of diversion during flooding or emergencies such as debris jams
- To help prevent ditch failures by improving control over diversion rates



Inflatable bladder gates are generally used in specialized applications where precise control of water is important.

Design and Construction Techniques

- The base structure is similar to a concrete diversion structure.
- Precise concrete forming is required.
- Steel assembly is bolted to concrete.
- Steel panels fold nearly flush with structure when deflated.
- The compressor system requires electricity, but can be solar powered.
- Available in sizes suitable for small diversions.
- Engineering design recommended.

CAUTION

- Bladders are sturdy, but can be damaged by debris, ice scouring, or excessive gravel deposition.
- Maintenance and electrical requirements may limit applications.
- Hire an experienced engineer to design the structure.

INFILTRATION GALLERIES

Infiltration galleries are constructed by burying rings, perforated pipe, or well screen in or adjacent to the stream channel, and daylighting the pipe in an open ditch downgradient.

Infiltration galleries may be appropriate for:

- Cobble and gravel bed rivers with low silt accumulation (B and some C channels)
- Smaller (less than 5 cubic feet per second) diversion rates
- Preventing entrainment of fish
- Laterally unstable channels where conventional structures fail

Design and Construction Techniques

- Infiltration galleries require adequate hydraulic gradient (ditch-water slope).
- Engineering calculations are required to size the length and diameter of screen.
- The size of slots or perforations depends on riverbed gravel sizes.
- Provision must be made to prevent scour exposure of buried screen.
- Provide access to allow backwashing (cleaning) of screens.

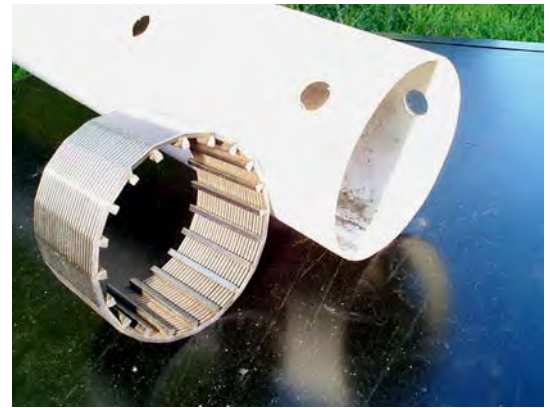

Infiltration galleries make use of buried screens or perforated pipe.



Concrete rings can make excellent pumping vaults when buried adjacent to a gravel bed stream channel.

CAUTION

- Annual maintenance is generally required with air or water backwashing to remove silts from the system.
- Channel downcutting, scour and fill, or migration can expose and damage the pipe.
- Design by an experienced engineer is recommended.

FISH PASSAGE AT DIVERSIONS

Fish passage is often impeded by irrigation structures, especially check board structures spanning the width of the channel. Fish passage is especially critical during spring and fall spawning runs.

Fish passage is promoted by low head diversions (such as engineered riffle diversion or rock weirs), and limited by high head diversions (flashboard structures) or unfavorable velocity or approach conditions (a common problem with culverts). Trout are deterred by drops over 1 foot, especially if there is no approach pool. Types of fish ladders include baffles, pool and weirs, and controlled side channels. In some case, it may be best to replace diversions with a pump to access water.



Pool and weir structures can be made of natural materials or engineered structures.

Design Considerations

- Low head rock weirs or engineered riffles can provide excellent passage when they can be accommodated in the channel.
- Constructed bypass channels around irrigation structures are preferred to Denil or other structural fish passage devices where feasible.
- Fish passage requires allowing streamflow to flow past a diversion during spawning runs.
- If in-channel rock weirs are used, maintain drops of less than 1 foot per structure.
- Provide an entrance pool before a drop, and an exit pool after a drop.



The flat floor and high drop of a pin and plank structure limits fish passage.

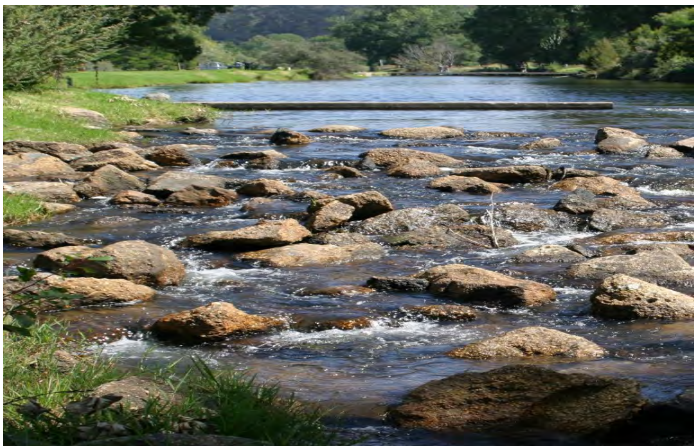

Engineered riffle diversions (armored riffle) are preferable to pin and plank structures.



Denil fish ladders can function but are less desirable than constructed bypass channels. These are not recommended for bull trout passage.

FISH PASSAGE AT DIVERSIONS (continued)

Bypass channels are preferred fish passage around irrigation structures if there is sufficient room. Channels are designed to meet stability criteria and provide fish passage over a desired range of flows. Bypass channels can be effective on small diversions but limited bypass flows may reduce effectiveness of this technique.

Design Considerations

- Channel hydraulics must be evaluated to ensure velocities and resting pools are sufficient for fish.
- Channel stability criteria must be defined to ensure bypass channel can withstand high flows.
- A weir or other flow regulating structure will be needed to control flows entering the bypass.
- Minimum bypass flow should be defined for critical time periods for fish passage.
- Location of the entrance below the diversion must be carefully selected to ensure fish will find the bypass.
- Attracting fish to the bypass entrance requires augmented flows.
- Designing the channel to have as many natural characteristics as possible (woody debris, vegetation, overhead cover, hydraulic diversity, resting pools, etc) aids with attracting fish.



Irrigation dam prior to retrofit with engineered riffle bypass.



Engineered riffle bypass provides fish passage.



Roughened bypass channel with rock weirs.

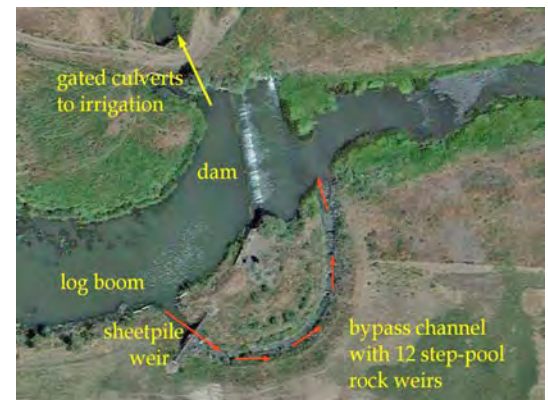

Pool and weir structures can be made of natural materials or engineered structures.

GUIDELINES FOR SMALL DIVERSION DESIGN

Diversion and headgate design needs to consider: 1) the ability to “check up” low water elevation to required operating level; 2) the ability of the diversion to pass peak flows, sediment and fish when not in use; 3) the ability of structures to withstand scour, icing, debris, and erosion; and, 4) provisions for fish/aquatic organism passage when diverting water as required by agencies.

The following design criteria reference the figure following these pages:

- 1. Channel Width.** Diversion structures should generally span the entire bankfull width to allow passage of fish, peak flow, sediment, debris and ice. Constricting the channel during spring runoff can result in adverse channel adjustments.
- 2. Bankfull Depth.** Identifying bankfull depth from the channel bottom can help define the width of channel that will be expected to flood every 1.5 to 2 years. In general, irrigation structures should allow free passage of flood events when not in use.
- 3. Low Water Elevation.** The low water elevation relative to the required ditch operating elevation will determine how high the water needs to be “checked up,” or raised by the irrigation diversion.
- 4. Required Ditch Operating Level.** The desired operating level is the water elevation required to maintain a full ditch during the irrigation season.
- 5. Headwater Requirement.** Headwater is the amount of water elevation gain required to “turn out,” or divert water into the ditch. Note that this elevation requirement is increased if the headgate is at right angles to the stream flow, and minimized if the headgate is more parallel to the flow because of the momentum of the flowing water. The tradeoff is that momentum also carries sediment and debris, so a balance and compromise is needed. The orientation/configuration of the intake is an important factor in diversion design. Small differences can have huge effects on performance.
- 6. Maximum Ditch Diversion Rate.** This is the full ditch capacity as defined by the water right. This may be greater than the seasonal or typical water diversion rate, but diversion design should consider both typical and maximum diversion rates.
- 7. Lateral Channel Stability.** Diversion structures in stable channels without significant lateral bank erosion or sediment deposition are less sensitive to design criteria such as bankfull dimension or flood passage criteria. If significant lateral instability or large sediment deposits are present, design should carefully consider channel hydraulics. In some cases, permanent structures may not be advisable due to potential impacts and probability of failure. Professional assistance is recommended for these structures.
- 8. Vertical Channel Stability.** If the stream channel bed is downcutting or aggrading (filling up), professional assistance may be warranted to select an appropriate design that considers restoring channel function.
- 9. Bedload/Sediment.** High sediment stream channels often make for high maintenance irrigation diversions. Designing the diversion to promote sediment passage during peak flow can reduce problems with channel instability or the ditch entrance filling up and requiring cleaning.

GUIDELINES FOR SMALL DIVERSION DESIGN (continued)

- 10. Diversion Structure Type.** Structures commonly include temporary gravel berms and tarps, wooden pin and plank/stop boards, rock weirs and vanes, concrete boxes with stop boards, and sometimes more sophisticated diversions with radial gates or inflatable bladders. In general, permanent structures that raise the stream water level year-round are not encouraged, as are temporary structures that result in annual streambed and bank disturbance. Ideally, a structure should minimize stream impacts and provide both diversion of water and allowance for passage of floods, debris, ice, and aquatic organisms.
- 11. Headgate.** The headgate helps control water and debris flowing into the ditch system, and a good design will help reduce the amount of headwater required to fill the ditch. Orienting the headgate to avoid damage by logs and ice sometimes requires a tradeoff between optimal water appropriation.
- 12. Bank Protection.** Diversion structures and headgates often require some bank stabilization measures. Minimizing the extent of channel alterations can help expedite permitting review.
- 13. Provision for Fish Passage.** Irrigation diversions should consider providing a means of fish passage when diverting water, and allow fish passage when not in use outside the irrigation season. This is particularly important in high value fisheries including tributaries that provide spawning and rearing habitat. Alternatives include a engineered riffle bypass, low rock weirs or riffles in lieu of pin and plank structures, Denil or other fish passage structures, porous tarps/poles instead of gravel berms, and pumps. The MFWP fish biologist that consults on the 310 permit can help select options and provide information on available funding sources to help cover the costs.



Older diversions that require maintenance or reconstruction offer opportunities for improvement in terms of functionality, fish passage, and stream function.

HEADGATES

Common Headgates

Waterman C-10 and R-5 Slide Gates

- Waterman gates are standard for small to medium diversions on all stream types.

C-10 Gates work well when:

- Round culvert meets diversion needs
- Positive seal for control of diverted water is needed
- Adjustable diversion rates are important

R-5 Gates may be preferred when:

- Using squash pipes, or wood headwalls in medium to large diversions
- Some leakage is acceptable (no ice problem)

Wooden Gates

- Constructed with a dimensional lumber box and flashboards to control the diversion rate
- Use on small diversions needing an inexpensive inlet gate
- Some leakage occurs through the stopboards, which can cause icing problems

Design Considerations

- Place headgates in a protected position to avoid damage by ice or debris.
- Placement on the outside of stable meanders more easily captures flows, but also more fish.
- Placement on inside of meanders results in sediment deposition at the gate.
- Use adequate fill to bed and bury the pipe.
- Headwalls are often required to retain fill.



A C-10 gate generally benefits from a headwall to stabilize fill. Rock can work, but the slope leaves the gate frame exposed to ice and debris.



An R-5 Headgate is a flat plate which slides in front of round or arch pipes.



This is a well-constructed gate with wingwalls and positive control at high flows.

FISH SCREENS

Fish Screening

Installing fish screens on diversions prevents the loss of both juvenile and mature fish in irrigation ditches (entrainment). Fish tend to go with the majority of the flow. Any sized diversion can trap substantial numbers of fish.

FWP and Trout Unlimited can help with planning, design, and funding of fish screens. Screens generally fall into two categories: active (moving parts) or passive (no moving parts). Passive screens can require less maintenance, but all fish screens require some level of perpetual maintenance.

Fish screens are typically used to protect important fish populations, where entrainment is negatively affecting a fishery. Without a screen, irrigators may reduce fish losses when closing a ditch by reducing flows to 25% and decreasing flow gradually over several days to allow fish to move back to the main channel or working with FWP to conduct fish rescue after irrigation season.

Design Considerations

- Screen design considers velocities to prevent fish and debris from getting impinged on the screen (approach velocity) and moving downstream (sweeping velocity).
- Mesh size is important to protect fry and clear debris.
- A bypass pipe or channel is needed to redirect fish to main channel. The bypass may require 5% of diverted flow.
- Active screens may be driven by a paddle wheel, solar, or an electric motor on line.
- Costs vary widely depending on design and size of installation, but range from \$5,000 to \$10,000 per cfs of diverted water.



Farmers screens operate with no moving parts and provide good fish protection characteristics.



Large drum screens can accommodate a wide range of flows (from 5 to 50 cfs or more).



Fish screens are effective for preventing fish loss in irrigation ditches. A by-pass channel is normally needed to redirect fry to the main channel. A flat screen relies on brushes to clear debris.

CAUTION

- Not all irrigation ditches require fish screens. It is best to consult with a biologist before considering a project.
- All fish screens should be designed and installed by an experienced professional.

FISH SCREENS (continued)

Fish screens can be helpful in excluding fish from irrigation systems, which can reduce fish mortality and improve fish populations. Before starting a project, it is important to consult a local fisheries biologist to discuss the potential improvements. Once all stakeholders decide a fish screen is warranted, project designers must consider a variety of project components, including:

- Will screened flow return to the stream?
- What is the water right and maximum diverted flow?
- Is there power to the site?
- What is the grade of the stream or ditch and the available water surface drop (head)?
- What is the allowable footprint for a screen?
- How much and what is the size of debris and/or sediment that will encounter the screen?
- What fish species and sizes are you protecting?
- Who will be maintaining the screen, and what are their preferences?

Location

In Montana, diversions are typically small and fish screens are often located in the irrigation ditch or instream.

In-ditch installations are downstream of control structures. This allows for easier inspection or maintenance, as well as protection from large debris and the public. Flow conditions are also more consistent and predictable. However, a bypass channel or pipe is necessary, meaning extra water will need to be diverted.

Instream structures allow fish to avoid a diversion altogether and does not require a bypass. However, maintenance may be more difficult, large woody debris may be damaging, and flow conditions may be more variable. Instream installations may not be feasible in larger waterbodies.



Many stakeholders should be involved when considering a fish screen.



Fish screens can be installed in a stream, side channel, or ditch. Individual site constraints will dictate options that can be considered.

CAUTION

- Icing, peak flows, debris flows, and vandalism can readily damage screens.
- All screens require periodic maintenance including debris removal, lubrication, seal replacement, and protection from ice damage.
- Carefully control the diversion rate to avoid overloading the screen capacity.

SCREEN TYPES - ACTIVE

Active fish screens manage debris with a cleaning method that is mechanical. These screens require some form of power, which can include electric, solar, or paddlewheel. They are typically operated seasonally, as the mechanical components do not tolerate icing. These screens include the Rotating Drum Screen, Vertical Flat Plate Screen, Vertical or Horizontal Traveling Belt Screen, or Cone Screen. The most common active fish screens in Montana are the Vertical Flat Plate screen and Rotating Drum Screen.

Vertical Flat Plate Screen

The self-cleaning mechanism is typically a set of vertical brushes driven by a paddle wheel, or motor drive where electricity or sufficient solar is available.

- Generally used for screening larger flows
- Requires a bypass pipe
- Screen typically cleaned with wiper brushes, but air bursts or spray jets are options
- Flow capacity is not limited, typically >10 cfs
- Head requirement approximately 0.2 to 0.6 ft
- Operating ditch depth is >8 inches
- Large screens may require access to pour concrete slab and stem walls



Vertical flat plate screens rely on paddle wheels to power the cleaning brushes. Bypass water returns young fish to the river channel.

Rotating Drum Screen

The self-cleaning mechanism requires power and is often used in conjunction with a paddlewheel. The drum rotates continuously, filtered water flows through the screen, and a portion of the diverted water (bypass water) carries debris off the screen face and back to the stream.

- The water level on the drum must be 65-85% of the drum diameter to clean effectively
- Screens are typically installed at 15-45 degree angles from the flow
- Can be designed for small to large flows (multiple screens)
- Water surface drop requirements is 0.3 to <0.5 ft depending on the design
- Bypass can be piped or open channel
- Operating ditch depth is >8"
- Large screens may require access to pour concrete slab and stem walls

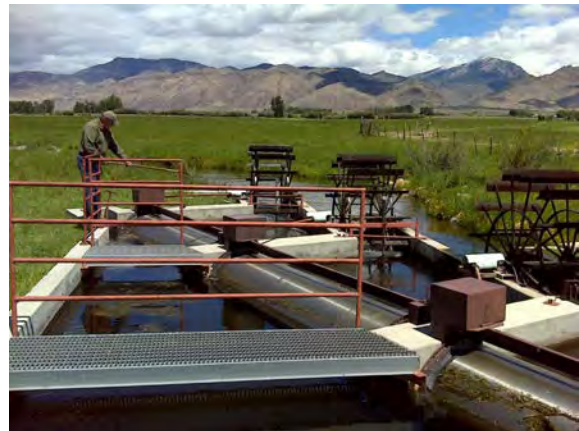

Drum screens can be configured with multiple bays to accommodate a wide range of flows.

SCREEN TYPES - PASSIVE

Passive fish screens manage debris through screen design and flow that sweeps along the screen and downstream. These screens include the horizontal flat plate screens (Farmers Screen, Watson Screen), the Coanda Screen, Corrugated Water Screen, and the Turbulent Fountain Screen. Passive screens are becoming increasingly popular due to the reduced maintenance requirements. The most popular passive screens in Montana have been the Farmers Fish Screen and the Coanda Screen.

Farmers Fish Screen

Farmers screens fit a variety of flows but screen size gets much bigger with larger capacity screens. They are constructed of a horizontal perforated stainless steel plate suspended in a pre-fabricated steel box. Filtered water drops through the screen, and a portion of the diverted water (bypass water) carries debris off the screen face and back to the stream with the fish.

- Requires appropriate entrance hydraulics
- Needs fairly steady diversion streamflows
- Good for shallow flow
- Flow capacity 1 to 25 cfs for modular screens
- Requires head of approximately 1 ft
- Consider access to place pre-fabricated steel or pour close-tolerance concrete slab and stem walls



The screen entrance is in the background; foreground shows screened water on the right and bypass channel (fish return) on the left.

Coanda Screen

Coanda fish screens are installed instream or in a side channel or ditch. Water pours over the top of the screen and screened water drops into the screen and out of a pipe. Fish and debris are transported over the screen.

- High flow capacity.
- Difficult to adjust bypass flow. Possible dewatering of screen toe and bypass during low flow periods.
- Plan to allow at least 0.25 cfs per linear of screen for bypass flow.
- Screen likely to create backwater or impoundment behind the screen.
- Requires a head greater than 1 ft.



In a Coanda, water flows down and out of a pipe, while fish and debris pass over the screen.

FLOW MEASUREMENT DEVICES

Water Rights and Flow Measurement

The Department of Natural Resources and Conservation or your local irrigation district may require measurement devices on diversions and ditches to verify correct water diversion rates.

Parshall and Montana Flumes:

- Are most common in larger ditches and flat gradient applications where backwater needs must be kept to a minimum
- Allow passage of sediment and debris
- Can be designed to measure both high and low flows with an insert
- Are available in pre-fabricated steel and fiberglass
- Require suitable bedding material or concrete to prevent leakage around the structure
- Become inaccurate if not level

Rectangular, V-Notch, and Cipoletti Weirs:

- Are common in smaller diversions
- Create backwater in the ditch because an upstream pool is required
- Can catch sediment or debris
- Can block fish passage out of a ditch if no entrance pool is present below the drop



Parshall flumes cause minimal backwater, and work well in low-gradient applications.



The Montana flume is a shortened version of the Parshall and must be free flowing (not backwatered).

Design Considerations

- Select the size of device based on both minimum flows and maximum capacity.
- Flat gradient ditches require devices (such as flumes) that create minimal backwater.
- Proper installation is required for accuracy. The device must be level, with no leakage or settling.
- Approach conditions for weirs require low velocities and “contracted” conditions for accuracy.
- Locate the device away from the ditch entrance to prevent damage by ice and debris.
- Design assistance is available from NRCS and water resources professionals.



The cutthroat flume has similar characteristics to the Montana flume but can be corrected for submergence.

FLOW MEASUREMENT DEVICES (continued)

Many types of specialized flow measurement devices are available beyond the more common types of flumes and weirs mentioned here. NRCS or other water resources professionals can help select and site appropriate devices for flow measurement.

Open Channel Flow

- Stage-discharge measurements can be used to develop a rating curve for an open channel with a staff gage.
- Rating curves are developed by taking flow measurements with a velocity meter at several different flow rates.
- Weed growth can shift the stage-discharge relationship during the irrigation season (especially in low-gradient ditches).
- Culverts can be used to estimate flow if conditions are “inlet controlled;” this condition occurs when flow is constricted and it drops as it enters the pipe.
- Open channel rating curves developed for staff gauges are not always an acceptable technique for water rights purposes.



This large concrete structure functions as a Cipoletti type weir.



Stage-discharge relationships can be developed for open channels (or culverts) to monitor flow in ditches.

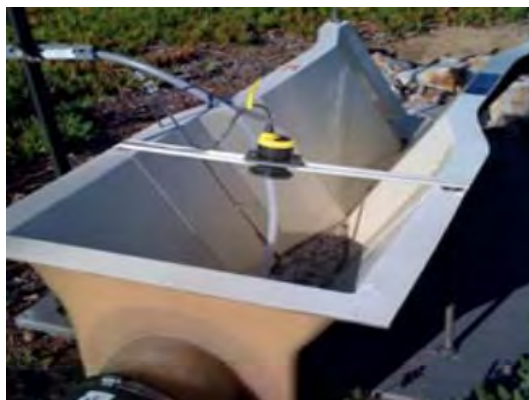

Numerous commercial water level/telemetry systems are available to measure flow remotely, including ultra-sonic and other sensors.



Rectangular weirs can be used to estimate flow if pooling of water behind structure is acceptable.

CAUTION

- Sizing a measurement device (or headgate) smaller than the water right could eventually forfeit the water right, though this is fairly uncommon.
- The device must not restrict the channel if placed in a natural stream.
- Access may be limited to the ditch easement for installation and maintenance of structures.

DAMS AND SPILLWAYS

Dams, berms, and dikes must be designed to be stable during saturated conditions. All dams and impoundments, whether on-stream or off-stream, require an emergency spillway to safely pass peak flows without eroding.

Design Considerations

- Dams generally require engineering design to ensure that fill materials and foundations are appropriate.
- All dams must include emergency spillways capable of safely carrying the 25- to 100-year flood.
- Spillways must be designed with adequate free-board to prevent overtopping of unprotected areas of the dike or dam.
- Earthen dam slopes must generally be shallower than 2:1 slopes (commonly 3:1 or less).
- Dam spillways can be rock, concrete, wood, or geotextile-lined vegetated swales.
- Consult with a qualified professional before constructing dams and spillways.
- Contact Montana DNRC's Dam Safety Program for additional information regarding permitting, construction and/or maintenance associated with a new or an existing dam



Dam spillway structures are commonly large rock or formed concrete and should be designed to withstand expected flood flows.



Canal checks are commonly used on small ponds to control water elevations. Canal checks and standpipe structures do not substitute for emergency spillways.

CAUTION

- Construction of new dams on perennial streams may be limited by fisheries, floodplain, water rights, or other environmental considerations.
- On-stream dams tend to accumulate silt, impede fish passage, and may raise water temperatures.
- Many small dams do not have adequate spillways and are prone to failure during flood conditions.
- The appearance of leaks on the dam face or at the toe may mean failure is imminent, especially if seeps are muddy or turbid.
- Dam designs should be reviewed by qualified professionals.

ROSGEN STREAM CLASSIFICATION

Chapter 2 introduced the concepts of stream form and function. Appendix 1 describes the geomorphic characteristics and relative stability of Rosgen stream types. The Rosgen Stream Classification System is widely used and useful for categorizing stream types based on form, which is dictated by physical processes. This system divides channels into seven main types (A to G).

The reason for classifying streams based on form (channel morphology) is to help understand stream condition and potential behavior under the influence of different types of changes. Rosgen stream classification helps to:

- Predict behavior of a river from its appearance
- Develop specific hydraulic and sediment relationships for a given stream type and relative stability
- Provide a system to apply knowledge from one stream reach to stream reaches having similar characteristics
- Provide a consistent frame of reference for communicating stream morphology and condition among a variety of disciplines

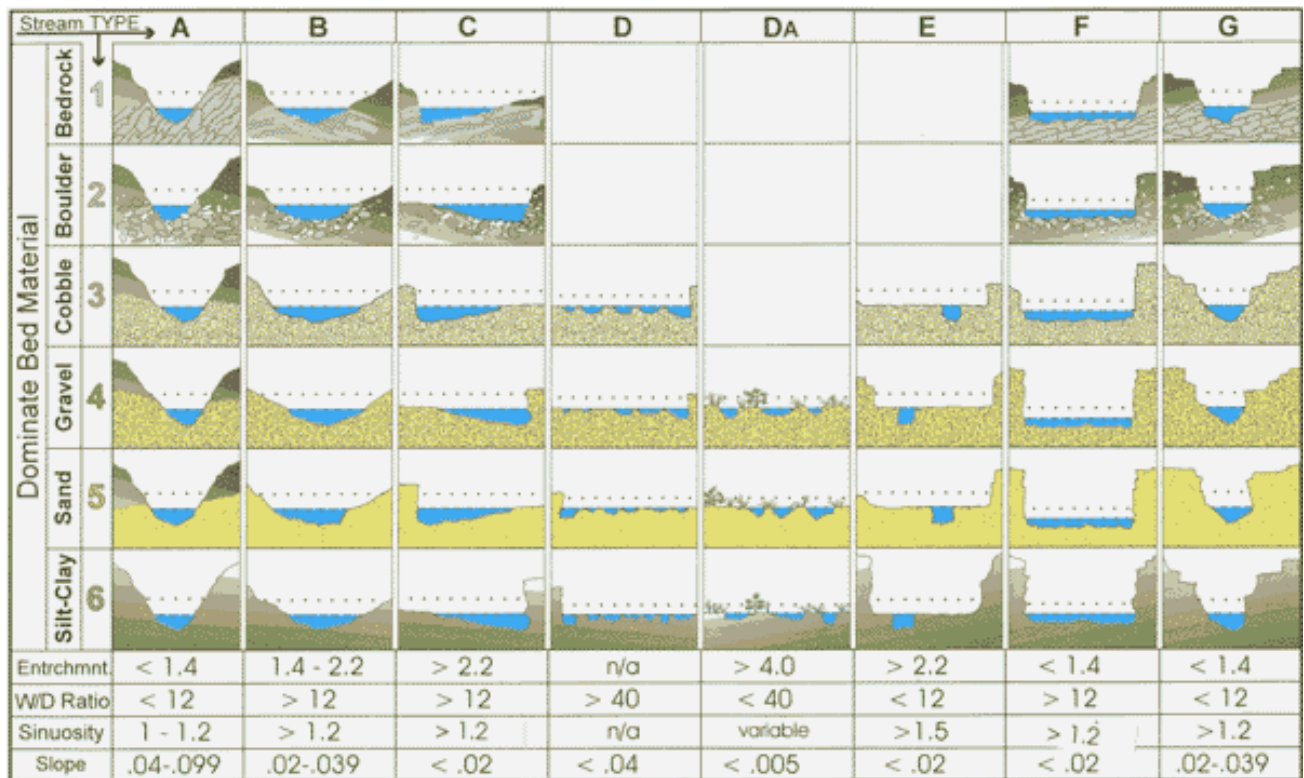

Applied River Morphology . Pagosa Springs: Wildland Hydrology Books, 1996. www.wildlandhydrology.com

ROSGEN STREAM TYPES

ROSGEN TYPE A STREAM

Good Condition



Poor Condition



Rosgen A channel in good condition

- Steep headwater channels (> 4% grade)
- Step/pool with large woody debris
- Low suspended sediment load
- Quite stable when formed in cobbles or boulders

Activities that cause problems

- Sidecast road fill from forest roads
- Loss of riparian trees and in-stream woody debris
- Poorly installed culverts (too steep or too long) that block fish passage
- Increased sediment from logging or poor road drainage
- Undersized culverts that caused deposition of outlet erosion

ROSGEN TYPE B STREAM



Good Condition



Fair Condition



Poor Condition

Rosgen B channels

- Fairly steep (greater than 2% grade)
- Can be wide and shallow (width-to-depth ratio greater than 12)
- May be fairly stable, especially when formed in large cobbles
- Frequently have irrigation diversions serving pastures lower in the valley
- Can provide important spawning habitat for fish

Stable B channels can adjust

- B channels can move lots of cobble and gravel at peak flow
- Channels may aggrade or degrade, or erode banks
- Instability is not usually caused by minor land-use changes or channel projects
- Geology plays an important role in structural changes
- Vegetation also plays an important role in channel stability

B channels can be unstable

- Instability can be inherent where bedload transport is high
- Ice jams and debris jams are frequent in these locations
- Irrigation diversions and stream crossings should avoid constricting the channel
- Woody debris can provide important fish habitat, and should be left if possible

ROSGEN TYPE C STREAM



Good Condition: moderate lateral channel movement, stable stream banks and channel form



Fair Condition: signs of channel adjustment including eroding banks, increased width to depth ratio, and sediment deposition in channel



Poor Condition: accelerated bank erosion, high width to depth ratio, migrating channel location, large and irregular sediment deposits

C channels are common

- Typically meandering streams in broad valleys with cottonwood-willow riparian corridors
- Can be wide and shallow
- May be fairly stable when banks and floodplain are well vegetated. The floodplain is active (floodprone)
- Provide important fisheries habitat

C channels are sensitive

- Carry large amounts of sediment during peak flow
- Rely on vegetation to maintain a stable width-to-depth ratio
- Lateral bank erosion up and downstream can be accelerated by poorly designed projects
- Soft bioengineering should be considered a substitute for hard methods such as rip-rap

C channels are dynamic systems

- Channel meanders migrate naturally over time
- Restricting meander or bank movement is usually counter-productive to channel stability
- Development of frequent mid-channel bars indicates reduced stability
- Attempts at channelization can lead to severe instability

C Channel Restoration

- Restoration of C channels should endeavor to enhance the plan, profile, and geometry of natural systems, including floodplain function and riparian vegetation
- Photos show the “poor condition” stream was restored to “good condition” using bioengineering; woody vegetation has not yet matured
- In general, hard armoring that restricts meander movement should be avoided

ROSGEN TYPE E STREAM



Good Condition

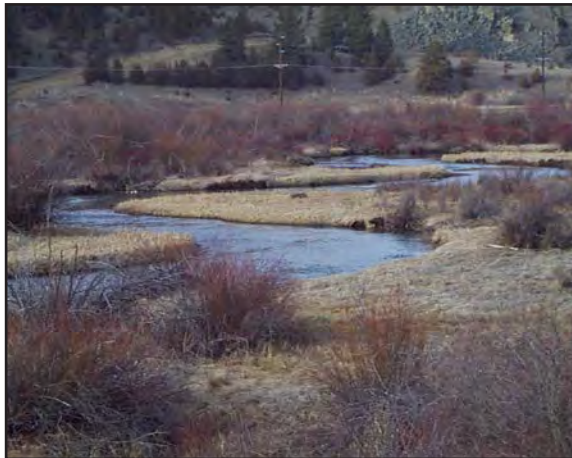

Fair Condition



Poor Condition

E channels are narrow and deep

- Commonly a strongly meandering stream in agricultural areas
- Low width-to-depth ratio (less than 12)
- Slope is gentle (< 2% grade)
- The floodplain is active (floodprone)
- Fairly stable when banks and floodplain are well vegetated
- Sedges and rushes often provide stability in place of riparian shrubs and trees
- Can provide important fisheries habitat

E channels are sensitive to land use or hydrology

- Channels rely on vegetation to maintain a stable width-to-depth ratio
- Lateral bank erosion up and downstream can be accelerated by poorly-designed projects
- Loss of vegetation or overgrazing can result in conversion to a wider and shallower C channel
- Soft bioengineering should be considered as a substitute for hard methods such as rip-rap
- Photos show the “poor condition” stream was restored to “good condition” using bioengineering

E channels are common in pasture and agricultural areas

- Grazing and confined animal operations can have significant impacts on channel health.
- Road approaches to stream crossings may dike floodplains if fill is elevated.
- Hard bank stabilization can often be avoided by use of vegetative methods.
- Use of barbs/vanes should be avoided.
- Degraded E channels may heal quickly if allowed to revegetate.

ROSGEN TYPES D, F, & G STREAMS



D channel



F channel



G channel

D channels are braided and unstable

- Braided channels have poor lateral bank stability and scour depths can be extreme
- Braided channels carry large amounts of bed-load gravel
- Design of stream crossings or channel restoration is difficult
- Stream crossings should avoid braided reaches
- C channels risk becoming D if disturbed by land use or other factors

F channels typically have high unstable banks

- Photo to the left shows E channel becoming established in a former F
- F channels are deeply incised or downcut, and meandering
- May develop in response to severe impacts (channelization, overgrazing, augmented flows), or be natural remnants of climate change
- Challenging to repair, and usually cannot be restored to former floodplain

G channels are typically characterized as gullies

- Found on alluvial fans, downcutting channels, or severely disturbed stream systems
- Can deliver large amounts of sediment to downstream reaches
- Rock weirs may help with grade control.
- Revegetation efforts may meet with limited short-term success

CHANNEL EVOLUTION OF ROSGEN STREAM TYPES

Interpreting Channel Stability Through Channel Evolution

Understanding streambank stability often requires an interpretation of geomorphic process. Stream channels commonly adjust to environmental stresses by changing bed elevation, width-to-depth ratio, channel form, and other morphometric variables. The process can commonly involve conversion from one channel type to another, and sometimes recovery to the original channel type occurs over time. Channels may also convert to a new type. Processes of scour and fill enable to channels to adjust to their environment. Understanding the existing stream condition is important for project design.

The diagram below illustrates several common scenarios for the stream channel adjustments. These adjustments frequently involve widening or deepening of the channel in response to land-use changes. Reestablishment of equilibrium conditions may result when environmental stress is relieved. Active restoration can be beneficial to accelerate this process.

Rosgen Channel Evolution by Stream Type

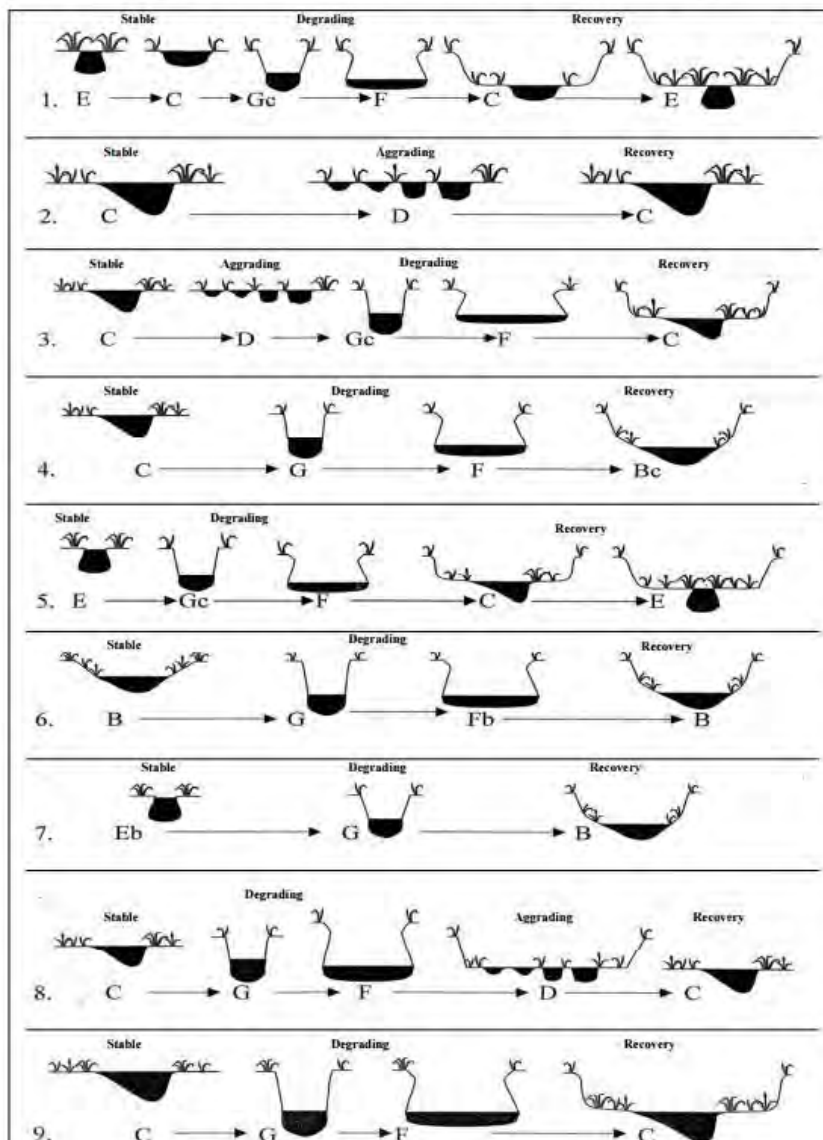

Common examples of four potential evolutions/progressions in stream type are shown above. These are examples of degradation, aggradation, and equilibrium process.

RIVER RESTORATION ANALYSIS TOOL (RiverRat)

RiverRAT is a set of tools and guidance for stream project development and review, including:

- Understanding how engineering and management actions affect the physical stream processes at varying scales (e.g., site, reach, and watershed)
- Understanding that uncertainty is inherent to all engineering and management actions in rivers
- Promoting solutions to identified problems that address the root causes, rather than simply treating the symptoms of the problem
- Acknowledging that human influences are fundamental components of all ecosystems, at all scales

RiverRat Considerations

- Is the problem identified?
- Are causes identified at appropriate scales?
- Is the project part of a larger restoration plan?
- Does the project consider ecological, geomorphic, and socioeconomic context?
- Do goals and objectives address problem, causes, and context?
- Are the objectives measurable?
- Were alternatives considered?
- Is the uncertainty and risk associated with the selected alternative acceptable?
- Do project elements collectively support project objectives?
- Are design and performance criteria defined for project elements?
- Does the project work with natural stream processes to maintain channel function and habitat?
- Is the technical basis sound for each element of the project?
- Are plans and specs sufficiently detailed to execute project?
- Does the plan address potential implementation impacts and risks?
- Are maintenance and monitoring considered?

Most landowners don't have the ability to work at the reach or watershed scale. The underlying considerations of the RiverRAT methodology can nevertheless help guide understanding and project selection. It is important to consider channel processes and function at the reach scale to develop effective projects.



In 1995, this channel was fairly straight and appeared stable. The area was split into lots for potential future development.



By 2015, the meander had encroached into the hayfield and floodplain. Is this a localized response to a lack of woody vegetation, a reach scale response, or larger adjustment process in the watershed?

PROJECT DESIGN

Project Planning, Design and Implementation

The over arching philosophy of RiverRat relies on the following principles:

1. Understand cause and effect. Identify primary causes and processes before selecting remedies. Problems observed are often symptoms of distant or broader issues. For example, if bank erosion is caused by aggradation or avulsion, bank stabilization efforts may need to address sediment transport and channel geometry to be successful.
2. Look both ways, upstream and downstream. Consider the project in the context of stream process both up and downstream. Your project should fit into the environment, not be a sore thumb.
3. Do not repair what is not broken. Channel features that appear to indicate channel instability, such as eroding streambanks, can also occur in a natural channel that is dynamically stable and healthy. Do not assume that streams need to be fixed without understanding stream process.
4. Keep the door open. Evaluate alternatives and insure the project does not adversely impact adjacent landowners or limit future options for restoration efforts. For example, projects that impose a hard, fixed channel alignment can be detrimental and limit options for subsequent restoration or management.
5. Accommodate uncertainty. What we do not know is equally as important as what we do know. Projects should accommodate the uncertainties inherent to natural systems and our understanding.
6. Question constraints. Project alternatives may be dismissed because they conflict with what are perceived as fixed site constraints (e.g., established infrastructure or lack of property easements). Better projects may result from removing the constraint (e.g., moving a structure, using a wider bridge, obtaining an easement) than by trying to force a stream to accommodate a fixed constraint.
7. Promote natural stream processes. Stream projects are more successful when they restore, rather than constrain, natural stream processes. Take the long view and work with the river. Constructed features should restore process, not just form. Adding large wood to a stream can be beneficial, but equivalent or better results may be achieved in the long term by revegetation strategies that restore processes and recruit wood naturally.
8. Do no lasting harm. Short-term project impacts, such as those associated with construction activities, are often necessary or unavoidable. Strive to avoid any lasting, adverse impacts from a project.
9. Invest wisely and protect your investment. Good projects are resilient. They promote a dynamic equilibrium that allows them to respond to change by adjusting the channel and floodplain. Even successful and resilient projects need protection. Easements, buffer strips and riparian corridors, instream flow protection, and designs that make allowances for change rather than introduce constraints on stream processes serve to protect successful projects.

(Adapted from RiverRat)

RIVERRAT SCHEMATIC

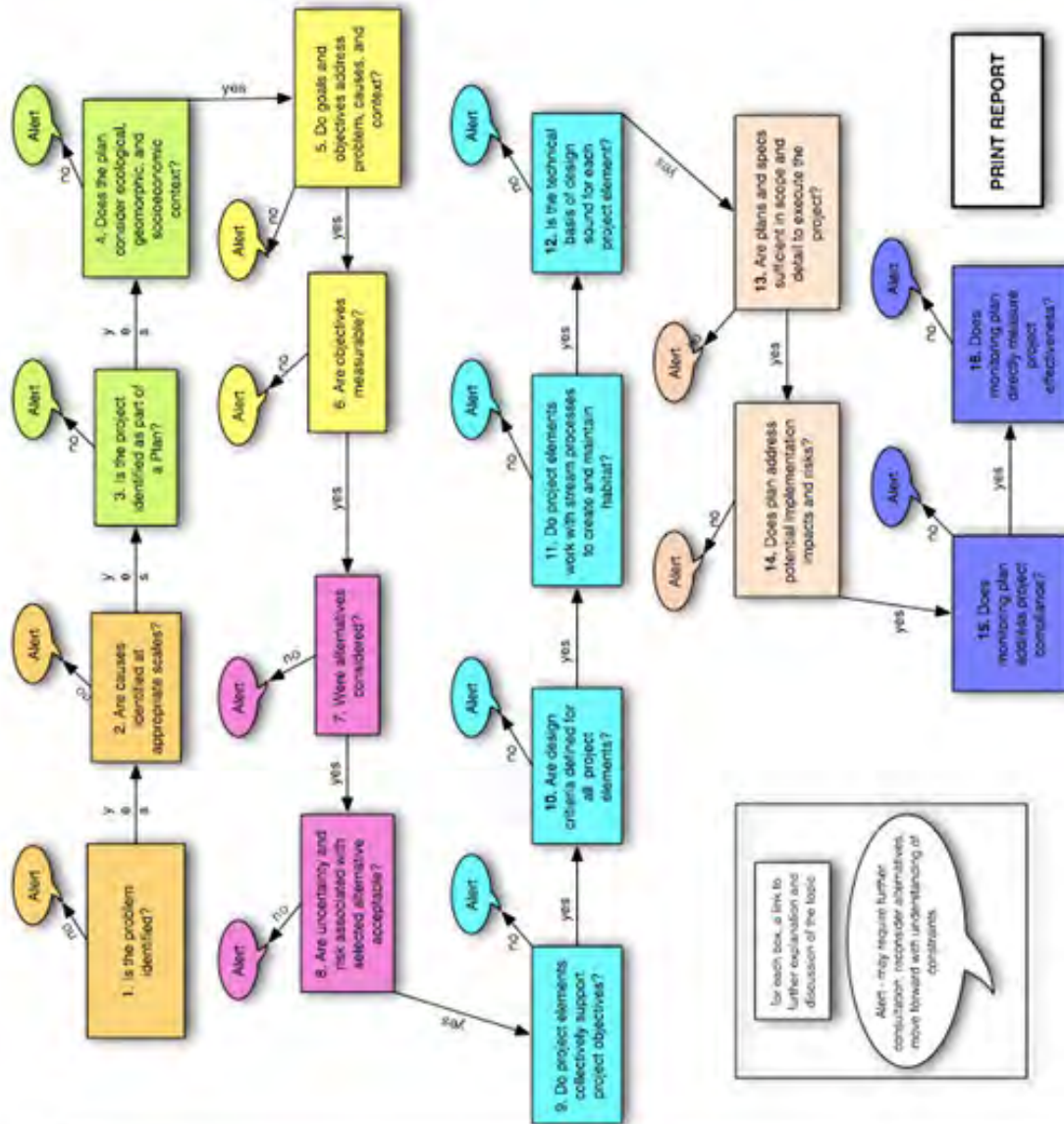
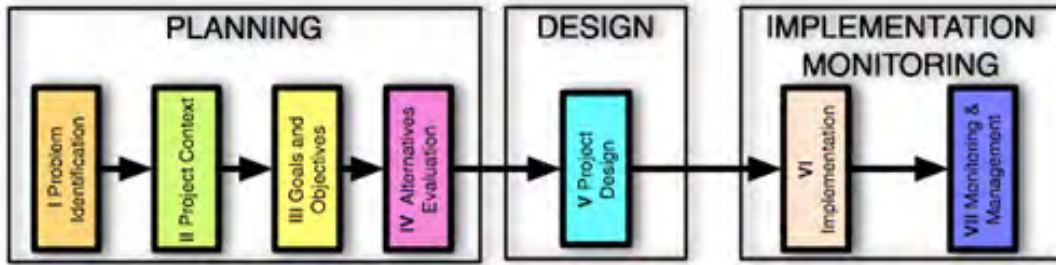

RiverRAT
River Restoration Analysis Tool

for each box, a link to further explanation and discussion of the tool

Alert - may require further consultation, reconsider alternatives, move forward with understanding of constraints

RIVER RESTORATION ANALYSIS TOOL AND DESIGN CRITERIA

RIVERRAT DESIGN CRITERIA

The following nine design criteria form the basis for stream project design. These are adapted from RiverRat methodology.

1. **Channel form and geometry**—specify the design discharge that the channel is intended to contain; define reach-averaged values and local variability in width, depth, and width/depth ratio; and specify a range of values for planform characteristics (pattern, sinuosity, meander wavelength, braiding index, etc.).
2. **Vertical stability**—design basis for substrate gradations, allowable range of bed scour and fill, specify whether grade control is allowable or required. Additionally, vertical stability criteria may specify sediment continuity objectives.
3. **Lateral channel stability and bank stability**—allowable range of channel shifting, discharge criteria for bank erosion and criteria for geotechnical bank stability, duration for which artificial bank protection and stabilization measures are required.
4. **Floodplain inundation/connectivity**—areal extent and location of floodplain inundation, duration, and frequency of inundation; allowable fluvial processes on the floodplain (overbank scour and sedimentation).
5. **Revegetation**—acceptable plant species and plant forms, time to maturity, maintenance and irrigation expectations, density, and percent cover required.
6. **Channel function and instream habitat**—area and type of habitat at specified flows, structural stability of habitat elements, and expected design life.
7. **Infrastructure protection**—flood frequency for stability and protection, impact to flood hazards, and water surface elevations.
8. **Construction costs and impacts**—allowable duration and standards for water quality degradation, allowable disturbance area, cost limits, construction period restrictions, and time frame.
9. **Sustainability criteria**—maintenance requirements, project life expectancy, susceptibility to floods and droughts, and resilience to systemic change.

The following pages address each of these criteria individually.



Physical constraints (highway above) may limit restoration options. (Clark Fork, 1995)



The river meander is moving downstream and recreating a floodplain. (Clark Fork 2015)

DESIGN CRITERIA: CHANNEL FORM AND GEOMETRY

The following approach is common for geomorphic channel cross section design:

- Specify the design discharge the channel is intended to contain, including composite floodplain and bankfull dimensions
- Define reach-averaged values and local variability in width, depth, and width/depth ratio.
- Specify a range of values for planform characteristics (pattern, sinuosity, meander wavelength, braiding index, etc.).
- Design by replicating analogue/reference reach, design by hydraulic analysis and engineered stability criteria.
- Define cross section using bankfull, or composite channel with bankfull and constructed floodplain within engineered terrace.



Degraded C4 (wide, shallow channel) trending to D4 (multiple thread, unstable form). This channel could recover through riparian management to promote woody vegetation.



Channel type C headed to D.



Potential restoration goal for degraded C channel (above).

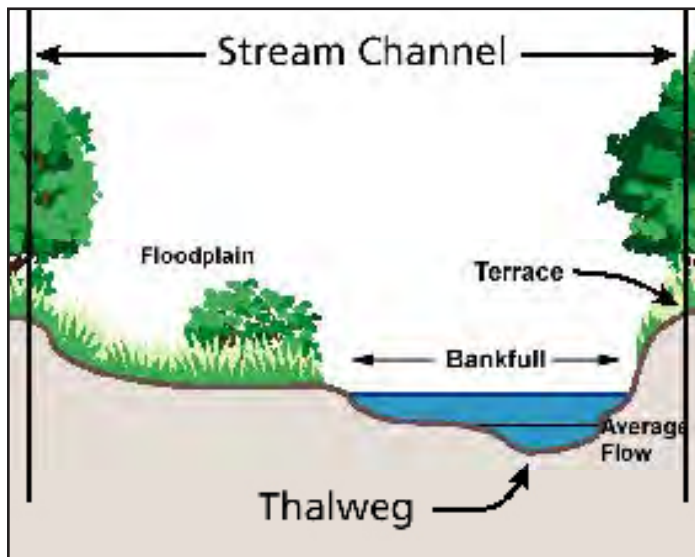

Bankfull cross section dimensions are fundamental to geomorphic design geometry. Bankfull corresponds to approximately the 1.5 year flood, which is the dominant flow that forms self-maintaining alluvial channels.

DESIGN CRITERIA: VERTICAL STABILITY-INCISION

Channel incision occurs both as natural process and through land use changes, channelization, human impacts, and changes in runoff regime.

Loss of floodplain connectivity and impaired riparian vegetation are major consequences of channel incision.

Alluvial channels without access to a functional floodplain at or near bankfull elevation can undergo substantial adverse adjustments. With loss of floodplain and overbank flows, hydraulic forces increase substantially at higher stage discharges resulting in accelerated channel incision and lateral erosion. This process is the channel's means of re-establishing a floodplain at a new base level.

Degraded and incised channels can sometimes be restored to a previous base level (bed elevation), but often will require restoration at the existing, post-impact elevation. In extreme cases, relocation of the stream reach may offer a more cost-effective means of restoration. Designs should consider the following:

- Look at design basis for substrate gradations and allowable range of bed scour and fill, and specify whether grade control is allowable or required
- Vertical stability criteria may specify sediment continuity objectives.
- Understanding vertical stability and scour and fill process is particularly important if “hard” structures such as weirs, vanes, or other in-channel rock features are being considered.
- Active channels with dynamic scour/fill and high sediment loads are challenging environments for hard structures.



Incised channels are associated with stream channel downcutting and loss of floodplain connectivity.



Incised channels may have stable stream bed elevations (Rosgen F type), or may be adjusting vertically (Rosgen G type).



Attempting to control flooding on aggrading channels with excavation and berms is rarely successful because the channel continues to fill.

VERTICAL STABILITY: AGGRADATION

Aggradation

Aggradation is a common cause of “abnormal” flooding conditions due to reduced channel capacity. Aggradation, or channel filling, results when more sediment enters a stream than the water can move.

Aggradation is common in depositional areas on alluvial fans, transitions at narrow canyons to wide valleys, and in flat valleys with certain sediment, slope, and discharge characteristics. Aggrading channels have high lateral instability (severe bank erosion) and may be braided with large gravel point bars and medial bars.

The tendency to aggrade or braid is natural in many river systems, but can be accelerated by channel changes (slumps, dewatering, land use, dikes or disturbance) that influence sediment supplies and carrying capacity.

Aggradation influences flooding conditions

Bankfull floods occur approximately every 1.5 to 2 years. Natural overbank flows should be expected frequently in channel types with a well-developed floodplain. Frequent flooding is not necessarily an indication of abnormal stream conditions.

Abnormal floods occur when streams experience non-equilibrium conditions, such as aggradation (channel filling), channel constriction (undersized structures), and extreme debris or ice jams.

Restoration of channel plan, profile, and geometry including floodplain function is generally required to address flooding associated with aggradation.

Streams need to move both sediment and water. Designs need to consider both.



The main channel (left side of photo) has completely filled with sediment and the channel has become laterally unstable.



Aggrading “filling” channels result from excess sediment supply or reduced transport capacity.



Gravel excavation in aggrading channels seldom results in satisfactory solutions to flooding.

DESIGN CRITERIA: LATERAL CHANNEL STABILITY AND BANK STABILITY

Bank stability objectives should balance the need for limiting channel movement with the ecological value of allowing alluvial channels to migrate.

An allowable range of channel movement, deformable banks and design life for stabilization measures should be defined.

Designs that emulate natural stability but do not harden banks beyond the range of natural should be considered where feasible.

- Channel adjustment is common in many channel types (especially C channels)
- Channel adjustment is often a natural process the stream uses to adjust sediment and water balance.
- River movement provides fresh substrate for rejuvenation of riparian vegetation (old stands of willow/cottonwood are replaced by new stands).
- Overgrazing, loss of riparian vegetation, extreme floods, channel blockages, and channelization must be considered.



Eroding terrace before restoration on Rosgen C3 channel type.



Restored bank using woody debris and sod transplants at the toe of the slope.



Eroding terrace on Rosgen C3 channel type before restoration.



Terrace with brush layer toe and geotextile fabric bankfull bench. This project failed after three years and returned to a similar condition as pre-construction.

DESIGN CRITERIA: LATERAL CHANNEL STABILITY AND BANK STABILITY (continued)

Interpreting Channel Stability Through Channel Evolution

Understanding streambank stability often requires an interpretation of geomorphic process. Stream channels commonly adjust to environmental stresses by changing bed elevation, width-to-depth ratio, channel form, and other morphometric variables. The process can commonly involve conversion from one channel type to another, and sometimes recovery to the original channel type occurs over time. Channels may also convert to a new type. Processes of scour and fill enable to channels to adjust to their environment. Understanding the existing stream condition is important for project design.

The diagram below illustrates several common scenarios for the stream channel adjustments. These adjustments frequently involve widening or deepening of the channel in response to land-use changes. Reestablishment of equilibrium conditions may result when environmental stress is relieved. Active restoration can be beneficial to accelerate this process.

Rosgen Channel Evolution by Stream Type

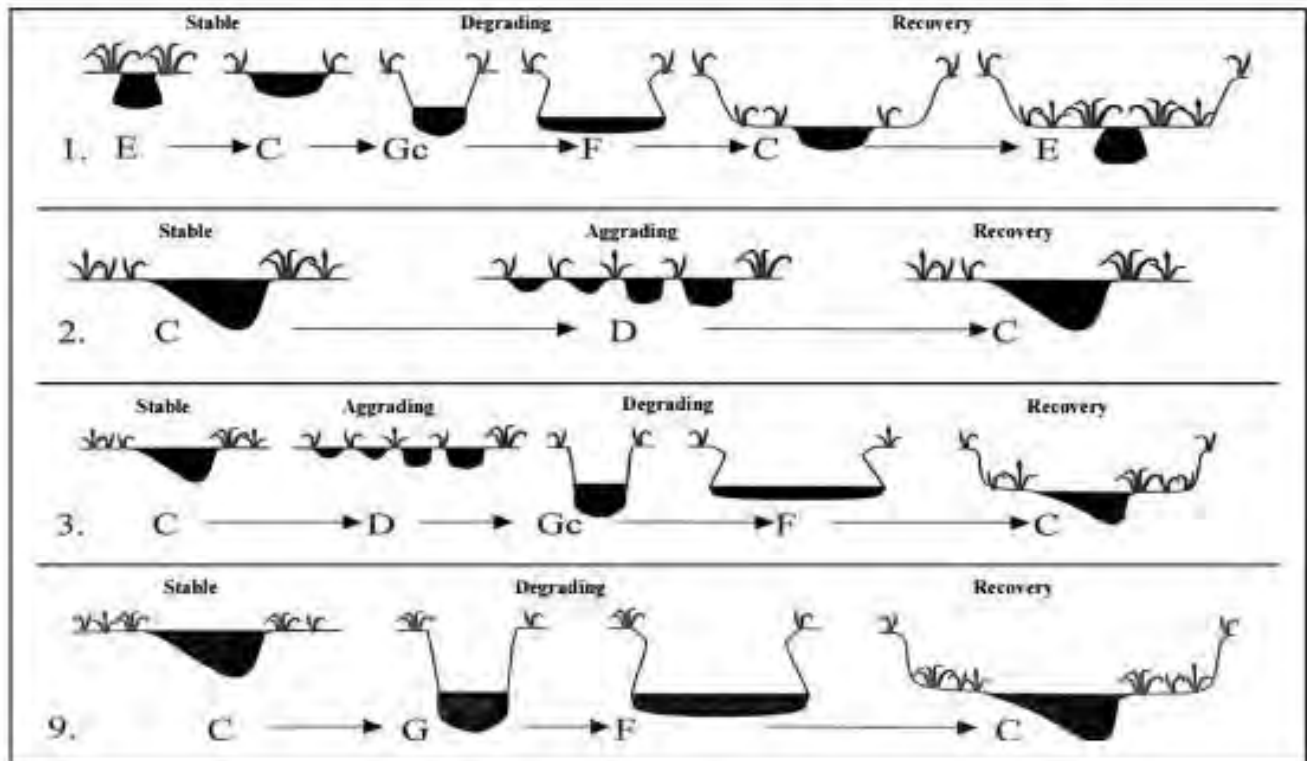

Common examples of four potential evolutions/progressions in stream type are shown above. These are examples of degradation, aggradation, and equilibrium process.

DESIGN CRITERIA: FLOODPLAIN CONNECTIVITY

Maintaining or restoring floodplain inundation, connectivity and function is a high priority for overall river function, ecological values, and channel stability. Project designs in aggrading or degrading (incised) stream reaches should carefully evaluate floodplain connectivity as part of the design. Projects that channelize, structurally harden banks or restrict lateral channel movement generally work against natural processes that maintain channel stability.

For most alluvial channels (e.g., Rosgen C, D and E), the floodplain begins to carry overbank flows at the bankfull flood event. This is typically the 1.5 to 2 year peak flow discharge. The benefits of connected floodplains include improved lateral and vertical channel stability, healthy riparian plant communities, floodwater storage and flood peak attenuation.

Channel and stream bank designs based on bankfull geometry and cross sections should endeavor to preserve or enhance floodplain connectivity whenever possible.

Design should consider:

- Area extent and location of floodplain inundation, duration, and frequency of inundation
- Allowable fluvial processes on the floodplain (overbank scour and sedimentation)
- In mapped FEMA floodplains, a hydraulic analysis evaluating project effects on the BFE (also known as no-rise)
- Complying with the no-rise requirement, or having a rise >0.00 ft authorized through the CLOMR/LOMR process, which can be costly



Channelization of streams frequently results in incised channels in disconnected floodplains. Big Spring Creek near Lewistown was channelized at the turn of the century.



Incised channels typically have bankfull heights below remnant floodplains. Channelization can result in incised channels.



Reactivating floodplains is a major objective in many restoration projects. This is Big Spring Creek in Lewistown after restoration.

FLOODPLAIN CONNECTIVITY *(continued)*

If channel flooding is abnormal due to on-site channel obstruction, the problem can be corrected by removing the blockage or replacing the structure to handle peak flows, ice, or debris.

If the channel is aggrading, cause and effect must be carefully evaluated. Finding a long-term solution may be difficult. The sediment source may be located off site, or the problem may be large scale, or regional. Dikes are of limited use because further aggradation may occur as dike or bank elevation is increased. Channel excavation or dredging is often a temporary solution because channels rapidly refill with sediment. Levees may raise flood water elevations, increasing flood stages upstream or across the river. Always consult your local floodplain administrator before building a dike or levee.



This dike was stabilized to protect downstream development from flooding, although the landowner with the dike did not particularly want to constrain the river.

Channel Excavation

Channel excavation may be appropriate when:

- Cause and effect are clearly understood (flooding is due to a culvert backwater or hillside slump into the channel)
- Cause can be addressed to prevent recurrence
- Gravel excavation occurs in a limited area, requires a single entry, and upstream sources are unlikely to rapidly refill the excavated section of the channel
- Fisheries and channel stability impacts are judged to be minimal

Dikes and Levees

Dikes and levees may be appropriate when:

- Protection of public infrastructure takes precedence over stream function
- Dikes can be designed to avoid substantial stream and floodplain impacts
- An engineered design meets all permit requirements
- Alternatives to dikes are unacceptable

Alternatives

Alternatives to dikes and levees include:

- Raising the grade of structure(s) threatened by frequent flooding
- Using berms to deflect flooding from a specific structure, rather than confining the stream channel
- Relocating threatened structures
- Restoring the channel to address channel instability issues

These alternatives to dikes can provide long-term security, can be cost effective compared to on-going maintenance typical of flood control projects, and are preferred by permitting agencies.

DESIGN CRITERIA: REVEGETATION

Bioengineered stream banks rely on successful vegetation of the site to restore naturally supported bank stability. Revegetation strategies for woody species can require 5 years for strong plant establishment, and 10+ years for plants to fully mature.

The first several years of plant growth focus on establishing healthy root systems, and less so leafy coverage. Irrigation through the first few growing seasons can greatly enhance survival and establishment of cuttings and plantings. Local native plant sources should be used whenever possible, rather than introducing non-native species.

Channel and streambank restoration projects should specify:

- Acceptable plant species and plant forms (cuttings, plugs, bareroot, seed, native sod)
- Time to maturity
- Maintenance (protection from browse (netting, chemical protection)
- Irrigation expectations
- Planting density
- Percent cover or stem count survival requirements



Creating an appropriate moisture regime is key to establishment of wetland and riparian species. Willow cuttings should be placed deep enough to intercept the water table.



Restoration of channel geometry goes hand-in-hand with revegetation efforts.



In 1999, the creek had unstable banks and poor riparian vegetation.



After channel reshaping, bank revegetation, and fencing, the bank recovered to a healthy riparian shrub and tree cover. (2014)

DESIGN CRITERIA: CHANNEL FUNCTION AND INSTREAM HABITAT

- Creating habitat should first focus on channel and floodplain form, function, and flexibility.
- Channel function includes ability to accommodate a range of flows, ability to adjust position, profile and dimensions. This dynamic is integral to creating bedform hydraulic diversity/complexity (i.e., habitat) and to promote healthy, self-sustaining riparian and wetland vegetation.
- Wood will degrade over time and bank stability will rely on deeply rooted vegetation.
- Constructed habitat features such as log jams, rootwads, log structures, boulders are commonly designed to be relatively non-deformable and securely anchored in place.
- Habitat complexity is an important attribute, structures that can adjust and evolve with the alluvial channel are preferred.
- Unfixed log jams may result in more natural channel features than fixed structures and be more cost effective.
- Habitat structures should be constructed with natural materials from local sources.
- Habitat structures can serve multiple functions, including grade control, protect the banks through flow deflection or by armoring.
- Structures can create pool habitat through local scour, create gravel bars in the lee zone, and provide sorted gravels for habitat. Shallow backwater areas and beaver dams (or constructed analogues) can provide rearing habitat.



Fish rely on hydraulic diversity in the channel bedform and woody debris is a key component of fish habitat.



Young fish benefit from microhabitat and velocity distributions, which are a function of channel form and structural components such as rock and wood debris. Diversity, not uniformity, makes for good fish habitat.



This dewatered channel provides an opportunity to see the five foot pool depth created by scour with a woody debris feature.

DESIGN CRITERIA: CHANNEL FUNCTION AND INSTREAM HABITAT (continued)

Design Considerations

The following factors should be considered for the creation of habitat features:

- Hydraulics - Potential effects on flow direction, water (i.e., flood) elevation, erosion, scour, etc.
- Scour depth - Streambed scour created by a structure is a key factor in stability.
- Buoyancy and drag forces - Must be evaluated for large woody debris that is submerged or projects into the stream.
- Materials - Use of native materials that are naturally present in the stream is preferable.
- Height/dimensions - Consider what is needed for a structure to be functional and fit the channel.
- Safety - Public safety (including recreational users) and potential for structures to block bridges/culverts must be considered.
- Design life/Performance Criteria - how long the structure is required to function, what range of flooding or channel adjustment will it withstand.
- Failure mode - what is likely to happen to the structure after it has ceased to be functional.



Fish habitat is provided by woody debris, healthy functioning riparian systems, and a variety of water depths and velocities. Side channels and backwater areas can provide important refuge for young fish.

DESIGN CRITERIA: INFRASTRUCTURE PROTECTION

River and stream management projects commonly involve protection of infrastructure from flooding or bank erosion/migration. Roads, houses, driveways, bridges, culverts that have been located within the pathway of the river may be unexpectedly at risk. Often these risks are predictable, but sometimes infrastructure has already been built in harm's way.

The costs of managing a river can be extensive. Bank stabilization costs can exceed \$600/ running ft of stream bank. Careful consideration is necessary to determine if managing the river/stream outweighs the costs of managing/relocating the infrastructure.

In FEMA mapped floodways/floodplains, projects that require protection of infrastructure may require engineering and hydrologic analyses to demonstrate the project:

1. Can withstand the 100 year flood
2. Does not raise or lower the 100 year flood elevation by more than 0.00 ft
3. Will not result in any adverse impacts to up or downstream landowners

Engineering and permitting costs for infrastructure protection can be costly.

New projects or infrastructure located near rivers or within floodplain should carefully consider all available information, including FEMA floodplain mapping, channel migration zones (CMZs, where available), and local understanding and experience with river dynamics.



Homes built on river terraces may be out of the floodplain but at risk from river migration. Protecting these sites can be costly and technically challenging.



Managing movement of large rivers is not assured of long-term success, and often requires ongoing maintenance and intervention.

CAUTION

- Costs of managing a river can quickly outstrip the value of a marginal property or development.
- Consultation with engineering or other qualified hydrology professionals is needed for design and permitting of projects to protect infrastructure.

DESIGN CRITERIA: CONSTRUCTION COSTS AND IMPACTS

Cost for bank restoration with bioengineering methods can range from \$150 to \$500 per linear foot, including design, permitting, materials and construction. Careful planning can help improve efficiency and minimize cost. Project cost is highly site-specific.

- Permitting costs for floodplain and 404 permits where biological assessments are required can add substantially to overall project costs.
- The construction window may have limited dates to protect spawning game fish. Minimizing potential impacts to water quality and aquatic life requires careful planning.
- Barrow sources for fill, vegetation, and large woody debris must be selected to minimize impacts on wetlands, floodplain or adjoining uplands.
- Allowable duration and standards for water quality degradation are typically defined through 318, 310 and other permitting processes. These should be clearly spelled out in the plan, including provisions for site dewatering during construction.
- Disturbance to the surrounding vegetation and wetland areas should be minimized whenever possible.



Construction should seek to minimize the amount of flowing water through the site.



Bioengineering treatments can be labor intensive, especially for installation of fabric. Bioengineering is preferred where vegetation treatments can be successfully established.



Flowing water through a construction site can result in severe water quality impacts. Potential sediment release must be addressed during the permitting process.

DESIGN CRITERIA: SUSTAINABILITY CRITERIA

Rivers and streams are dynamic, evolving natural systems. Gravel bed rivers naturally migrate across the floodplain and adjust to environmental change and land use.

Projects that promote and work with natural process are more likely to function well in the long term. Interventions that contradict river natural process are expensive and often high-maintenance.

Defining “long run” sustainability and resilience means understanding natural channel process, understanding project objectives and project design life, and potential limitations.

In many river environments, conditions such as lateral bank erosion displace to a different location (often downstream) over time. Over the course of 10 or 20 years, erosive forces may move due to downstream meander migration or avulsion.

Project design should consider the required longevity and strength of bank treatments. Bioengineered “soft” treatments are often sufficiently robust to protect banks for the needed duration.

Recognize that “permanent” solutions are rarely permanent. Strategies that accommodate natural channel movement and self-maintaining vegetation are generally the most resilient long-term approaches for streambank and floodplain stability.

Design criteria should clearly identify performance expectations. Deformable banks and allowable channel adjustments should be identified.

Floodplain permitting criteria may require protection from erosion the 100-year flood for structural protection. For many projects, this degree of hardened channel is contrary to sustainability or natural resilience.



Any in-stream structures, including habitat features, require careful design and placement to be successful. Channel scour and fill can result in structure failures.



The structure functioned well and was located just upstream of the above photo. Success of in-stream structures can be highly site-specific.



This bioengineered bank is deforming as the river undercuts the encapsulated soil lifts. Deformable banks are frequently incorporated into restoration strategies, but may be undesirable for structural protection.

GLOSSARY

Aggradation – Filling in, deposition; a reach where sediment accumulates in the channel is said to be aggrading.

Armoring – A layer of stone or other suitable material placed in the stream to protect the banks from erosion.

Avulsion – Creation of a new channel, usually during flood conditions.

Backfill – Adding dirt or gravel to replace material removed during construction.

Backwater – A rise in the water level upstream of an obstruction or constriction in the channel.

Bankfull discharge – The flow rate that moves sediment and forms or removes bars and meanders to maintain the average characteristics of a stream. In many stream types, it is associated with the flow that just fills the natural channel to the top of its banks and at a point where the water begins to overflow onto the active floodplain.

Bankfull elevation – The point where water fills the channel at bankfull discharge, in most cases just before beginning to spill onto the floodplain. Indicators include a topographic break in bank slope, change in sediment characteristics, and change in vegetation.

Bankfull width – The width of a channel measured at bankfull elevation.

Bar – A submerged or partly submerged deposit of sediment and gravel within a stream channel.

Bedload – Sediment or gravel that is not suspended in the stream but is rolled or dragged along the stream bottom.

Best Management Practices (BMPs) – Guidelines for managing the use of a resource in a manner that protects the resource and promotes ecological and economic sustainability.

Channel migration – The movement or shifting of a stream channel across the width of its floodplain as banks erode and point bars expand.

Channel pattern – The winding of a stream channel as seen from above (in plan view).

Channel profile – The shape of a stream channel along its length or longitudinal axis. A stream's profile shows the nature and amount of elevation change over a given reach.

Channel slope – The gradient of a stream's bed; the downhill angle over which a stream flows.

Channelization – Straightening of a reach, or confinement within constructed earthfill (or other object).

Deadman – A buried log serving as an anchor.

Degradation – Scouring; a reach where sediment is removed is said to be degrading; often downcutting the bed.

Deposition – Settling out of sediment loads, which results in shallows, bars, and lateral channel movement.

Dike – An embankment to control flooding, usually on or near the banks of a stream (see Levee).

Entrenchment – The degree to which a stream is vertically contained within its channel and the valley floor. Some stream types may be naturally entrenched, other have been entrenched by the use of dikes or other artificial structures.

Fascine – A long bundle of branches or other material placed to prevent erosion and soil movement.

Fish ladder – Angle iron or other baffles placed in a culvert to improve fish passage upstream.

Gabion – A wire mesh basket filled with rock.

Geotextiles – Fabric or matting made from natural fibers such as coconut or jute, sometimes woven into a plastic mesh.

Head cutting – The upstream migration of the stream bottom due to erosion. A steep break in channel slope or bed, often unstable and migrates upstream.

Incised – A stream is said to be incised when the bankfull flows (1.5- to 2-year) cannot reach the floodplain.

Lateral instability – A condition where a stream channel is prone to migrating side-to-side across its floodplain.

Levee – An embankment to control flooding, usually set back from the banks of a stream (see Dike).

Ordinary High Water Mark - Defines the boundaries of streams, and other aquatic features, for a variety of federal, state, and local regulatory purposes. Generally, OHWM corresponds to bankfull elevation.

Point bar – The silt, gravel, or cobble that extends into the water from the inside of a bend or meander.

Revetment – A facing of trees, stones, or other material to reinforce a streambank.

Resting pool - A deep pool downstream of the outlet of a culvert that allows fish to rest before swimming through the culvert.

Riparian – Areas adjacent to or influenced by water from streams and rivers.

Scour - The removal of underwater material by waves or current, especially at the base of a stream bank or shoreline.

Thalweg - The deepest part of a stream channel, where the fastest current usually occurs.

Toe - The base of a slope or stream bank.